



# PARTS & SERVICE MANUAL

## Impinger II Express Series

Domestic Models

---

### MODELS:

Please note that the model numbering system changed March 2007. The chart below shows the old model numbering system and its matching new model number.

Old Model Number	→	New Model Number
1116-080-A (or A1)	→	1116-00z-U-Kxxxx
1116-062-8R	→	1116-00z-U-Kxxxx
1116-023-8	→	1116-00z-U-Kxxxx
1117-080-A (or A1)	→	1117-00z-U-Kxxxx
1117-023-8	→	1117-00z-U-Kxxxx
1130-080-A (or A1)	→	1130-00z-U-Kxxxx
1130-08H-A		N/A
1131-080-A (or A1)	→	1131-00z-U-Kxxxx
1131-08H-A		N/A
1132-080-A (or A1)	→	1132-00z-U-Kxxxx
1132-08H-A	→	1172-00z-U-Kxxxx
1132-002-8	→	1174-00z-U-Kxxxx
1132-023-8	→	1132-00z-U-Kxxxx
1133-080-A (or A1)	→	1133-00z-U-Kxxxx
1133-08H-A	→	1173-00z-U-Kxxxx
1161-080-A	→	1131-00z-U-Kxxxx
1162-080-A	→	1132-00z-U-Kxxxx
N/A		1178-00z-U-Kxxxx

P/N: L371076  
REV: 10.19.09

Lincoln Foodservice Products, LLC  
1111 North Hadley Road  
Fort Wayne, Indiana 46804  
Telephone: 260.459.8200  
Fax: 888.790.8193  
Technical Support: 800.678.9511  
lincolnfp.com

## MODEL NUMBER KEY

EXAMPLE: 1116-B00-E-K1801

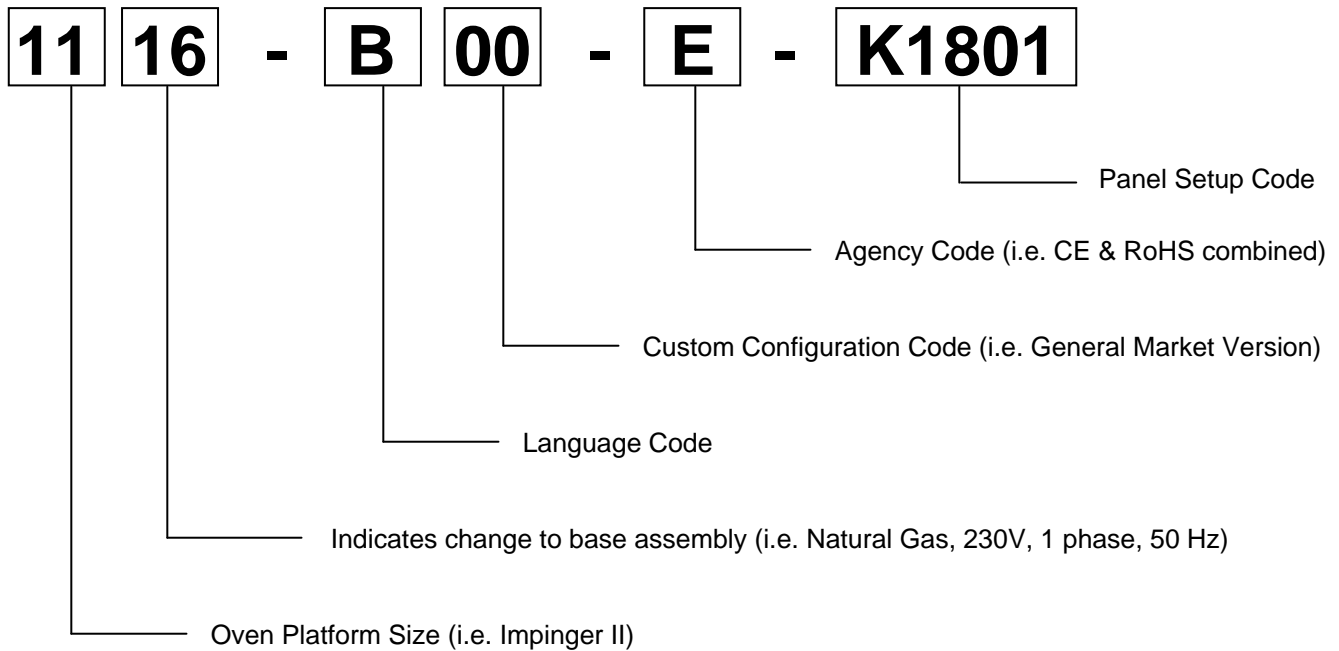

CODE	LANGUAGE	COUNTRY	CODE	LANGUAGE	COUNTRY
0	English	Dom. & Int. Default	N	Finnish	Finland
B	French	France/Luxembourg	O	Restricted	---
C	German	Germany	P	Norwegian	Norway
D	Italian	Italy	Q	English	Japan
E	Spanish	Spain	R	Swedish	Sweden
F	English	UK/India/Africa/Hungary	S	English	Australia
G	Spanish	Mexico/Latin America	T	Mandarin	China
H	Portuguese	Portugal	U	Restricted	---
I	Not Used	---	V	English	Pacific Rim/Korea
J	Danish	Denmark	W	English	Middle East
K	Dutch & French	Belgium	X	Not Used	---
L	Dutch	Netherlands	Y	Not Used	---
M	Greek	Greece	Z	Not Used	---

### AGENCY CODE TABLE

CODE	AGENCY
N	No Agency
E	CE & RoHS compliance combined
U	US & Canada compliance only
A	Advantage style oven to be phased-out
B	Australia AGA

## SEQUENCE OF OPERATION IMPINGER II ADVANTAGE, GAS (OVENS WITH PUSH BUTTON CONTROLS)

Old Model Number	→	New Model Number	Gas Type	Voltage	Hz.	Phase
1116-080-A (or A1)	→	1116-00z-U-Kxxxx	Natural Gas	120 VAC	60 Hz.	1
1116-062-8R	→	1116-00z-U-Kxxxx	Natural Gas	120 VAC	60 Hz.	1
1116-023-8	→	1116-00z-U-Kxxxx	Natural Gas	120 VAC	60 Hz.	1
1117-080-A (or A1)	→	1117-00z-U-Kxxxx	LP Gas	120 VAC	60 Hz.	1
1117-023-8	→	1117-00z-U-Kxxxx	LP Gas	120 VAC	60 Hz.	1

POWER SUPPLY	Electrical power is supplied to the oven by a three-conductor cordset. Voltage from the black conductor to the white conductor is 120VAC. Black conductor is hot White conductor is neutral. Green conductor is ground.
CONTROL BOX AUTO COOL DOWN	When the temperature in the control box reaches 120°F ± 3° (48.9°C ± 1.7°), the cooling fan thermostat will switch power to the control box cooling fans. The thermostat will interrupt power to the cooling fans when the control box temperature falls to 100°F ± 3° (37.8°C ± 1.7°).
MAIN FAN CIRCUIT	Power is permanently supplied, through a 10 amp fuse, to the normally open main power switch. Power is also supplied to the normally open cooling fan thermostat. Closing the main power switch supplies 120VAC to the main fan motor, the cooling fan motors, the primary of the control transformer, the conveyor motor and to the ignition control.
BURNER CIRCUIT	Closing the main power switch supplies 120VAC to the burner blower motor. 120VAC is also supplied, through the main fan centrifugal switch (this switch closes when the main fan reaches approx. 1600 RPM) and the normally closed oven cavity hi-limit thermostat, to the primary of the burner transformer. 120VAC is also supplied to the oven control.
IGNITION CONTROL	The ignition control operates on both 24VAC and 120VAC. When the control is energized by 24VAC from the transformer, 120VAC is switched by the ignition control to the hot surface igniter for 45 seconds for the hot surface igniter warm up. The igniter glows red, 24VAC is switched to the gas valve, which opens, and ignition should now occur.
TEMPERATURE CONTROL	Closing the main power switch supplies 120VAC to the primary of the oven control transformer. Secondary voltage, 24VAC, is supplied to the oven control. The oven control is set to desired temperature. The thermocouple will provide varying millivolts to the oven control. The oven control supplies 120VAC to the temperature regulation valve at intermittent intervals to maintain the desired temperature. The display on the oven control will indicate when the temperature regulation valve is energized. NOTE: The display also indicates oven temperature.
CONVEYOR DRIVE	Closing the main power switch supplies 120VAC to the conveyor motor and to the primary of the control transformer. Secondary voltage, 24VAC, is supplied to the oven control. Setting the oven control to the desired time outputs voltage, through a reversing switch, to the conveyor motor. NOTE: The conveyor system uses a hall effect sensor and magnet to prove operation of the conveyor motor. If the conveyor motor is not running, "BELT JAM" is indicated on the display.

**SEQUENCE OF OPERATION**  
**IMPINGER II ADVANTAGE, ELECTRIC – S/N 080921000016 & BELOW**  
**(OVENS WITH PUSH BUTTON CONTROLS)**

Old Model Number	→	New Model Number	Voltage	Hz.	Phase
1130-080-A (or A1)	→	1130-00z-U-Kxxxx	120/208	60 Hz.	1
1130-08H-A	→	N/A	208	60 Hz.	1
1131-080-A (or A1)	→	1131-00z-U-Kxxxx	120/240	60 Hz.	1
1131-08H-A	→	N/A	240	60 Hz.	1
1132-080-A (or A1)	→	1132-00z-U-Kxxxx	120/208	60 Hz.	3
1132-08H-A	→	1172-00z-U-Kxxxx	208	60 Hz.	3
1132-002-8	→	1174-00z-U-Kxxxx	208	50/60 Hz.	3
1132-023-8	→	1132-00z-U-Kxxxx	208	50/60 Hz.	3
1133-080-A (or A1)	→	1133-00z-U-Kxxxx	120/240	60 Hz.	3
1133-08H-A	→	1173-00z-U-Kxxxx	240	60 Hz.	3
1161-080-A	→	1131-00z-U-Kxxxx	120/240	60 Hz.	1
1162-080-A	→	1132-00z-U-Kxxxx	120/208	60 Hz.	3
N/A	→	1178-00z-U-Kxxxx	120	60 Hz.	3

POWER SUPPLY	Electrical power to be supplied to the oven by a three conductor service for single phase and a four conductor service for three phase. Black conductor is hot. Red conductor is hot. Orange conductor is hot (used for three phase only). White conductor is neutral. Green conductor is ground.
CONTROL BOX AUTO COOL DOWN	When the temperature in the control box reaches 120°F ± 3° (48.9°C ± 1.7°), the cooling fan thermostat will switch power to the control box cooling fans. The thermostat will interrupt power to the cooling fans when the control box temperature falls to 100°F ± 3° (37.8°C ± 1.7°).
MAIN FAN CIRCUIT	Power is permanently supplied through the 10 amp fuses, through the normally closed oven cavity hi-limit thermostat, to the normally open main power switch. Power is also supplied to the normally open cooling fan thermostat. Closing the main power switch energizes the coil of the oven start relay, it's contacts close enabling the 20 minute time delay relay. The 20 minute time delay relay supplies 120VAC to the oven fan relay, these normally open contacts now close supplying 208/240VAC to the main fan motor. 120VAC is also supplied to the cooling fans. 208/240VAC is supplied to the primary of the control transformer, the conveyor motor and, through the air pressure switch, to the oven control.
TEMPERATURE CONTROL	Closing the main power switch supplies 208/240VAC to the primary of the control transformer. Secondary voltage, 24VAC, is supplied to the oven control. The oven control is set to desired temperature. The thermocouple will provide varying millivolts to the oven control. The oven control supplies 208/240VAC to the coil of the heater relay at intermittent intervals to maintain the desired temperature. The display on the oven control will indicate when the heater relay is energized. NOTE: The display also indicates oven temperature.
CONVEYOR DRIVE	Closing the main power switch supplies 208/240VAC to the conveyor motor and to the primary of the control transformer. Secondary voltage, 24VAC, is supplied to the oven control. Setting the oven control to the desired time outputs voltage, through a reversing switch, to the conveyor motor. NOTE: The conveyor system uses a hall effect sensor and magnet to prove operation of the conveyor motor. If the conveyor motor is not running, "BELT JAM" is indicated on the display.
AUTOMATIC COOL DOWN	When the oven is started, the time delay relay timing circuit is enabled, permitting the oven fans to run approximately 20 minutes after the oven is shut off, to cool the oven. The time delay relay will keep the coil of the fan relay closed, maintaining operation of the main fan and cooling fans.

**SEQUENCE OF OPERATION**  
**IMPINGER II ADVANTAGE, ELECTRIC – S/N 0809210000017 & ABOVE**  
**(OVENS WITH PUSH BUTTON CONTROLS)**

Old Model Number	→	New Model Number	Voltage	Hz.	Phase
1130-080-A (or A1)	→	1130-00z-U-Kxxxx	208	60 Hz.	1
1130-08H-A	→	N/A	208	60 Hz.	1
1131-080-A (or A1)	→	1131-00z-U-Kxxxx	240	60 Hz.	1
1131-08H-A	→	N/A	240	60 Hz.	1
1132-080-A (or A1)	→	1132-00z-U-Kxxxx	208	60 Hz.	3
1132-08H-A		1172-00z-U-Kxxxx	208	60 Hz.	3
1132-002-8		1174-00z-U-Kxxxx	208	50/60 Hz.	3
1132-023-8		1132-00z-U-Kxxxx	208	50/60 Hz.	3
1133-080-A (or A1)		1133-00z-U-Kxxxx	240	60 Hz.	3
1133-08H-A		1173-00z-U-Kxxxx	240	60 Hz.	3
1161-080-A		1131-00z-U-Kxxxx	240	60 Hz.	1
1162-080-A		1132-00z-U-Kxxxx	208	60 Hz.	3
N/A		1178-00z-U-Kxxxx	120	60 Hz.	3

POWER SUPPLY	Electrical power to be supplied to the oven by a three conductor service for single phase and a four conductor service for three phase. Black conductor is hot. Red conductor is hot. Orange conductor is hot (used for three phase only). Green conductor is ground.
CONTROL BOX AUTO COOL DOWN	When the temperature in the control box reaches 120°F ± 3° (48.9°C ± 1.7°), the cooling fan thermostat will switch power to the control box cooling fans. The thermostat will interrupt power to the cooling fans when the control box temperature falls to 100°F ± 3° (37.8°C ± 1.7°).
MAIN FAN CIRCUIT	Power is permanently supplied through the 10 amp fuses, through the normally closed oven cavity hi-limit thermostat, to the normally open main power switch. Power is also supplied to the normally open cooling fan thermostat. Closing the main power switch energizes the coil of the cool down timer relay, its contacts close enabling the 20 minute time delay relay. The 20 minute time delay relay supplies 208/240VAC to the oven fan relay, these normally open contacts now close supplying 208/240VAC to the main fan motor. 208/240VAC is also supplied to the cooling fans. 208/240VAC is supplied to the primary of the control transformer, the conveyor motor and, through the air pressure switch, to the oven control.
TEMPERATURE CONTROL	Closing the main power switch supplies 208/240VAC to the primary of the control transformer. Secondary voltage, 24VAC, is supplied to the oven control. The oven control is set to desired temperature. The thermocouple will provide varying millivolts to the oven control. The oven control supplies 208/240VAC to the coil of the heater relay at intermittent intervals to maintain the desired temperature. The display on the oven control will indicate when the heater relay is energized. NOTE: The display also indicates oven temperature.
CONVEYOR DRIVE	Closing the main power switch supplies 208/240VAC to the conveyor motor and to the primary of the control transformer. Secondary voltage, 24VAC, is supplied to the oven control. Setting the oven control to the desired time outputs voltage, through a reversing switch, to the conveyor motor. NOTE: The conveyor system uses a hall effect sensor and magnet to prove operation of the conveyor motor. If the conveyor motor is not running, "BELT JAM" is indicated on the display.
AUTOMATIC COOL DOWN	When the oven is started, the time delay relay timing circuit is enabled, permitting the oven fans to run approximately 20 minutes after the oven is shut off, to cool the oven. The time delay relay will keep the coil of the fan relay closed, maintaining operation of the main fan and cooling fans.

# SCHEMATIC DIAGRAM

## MODEL 1116-080-A, 1116-080-A1, 1117-080-A, 1117-080-A1

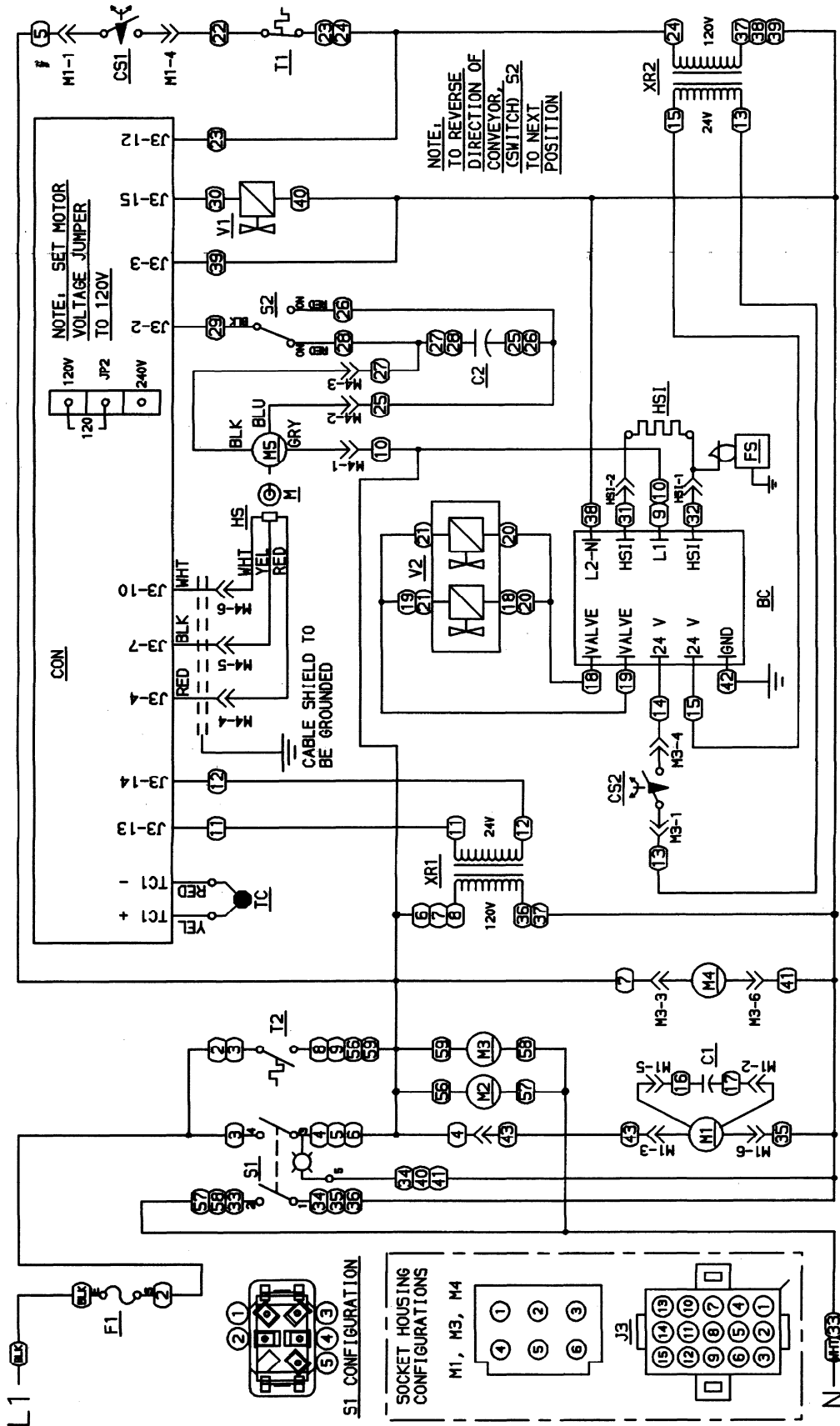

**Lincoln**  
**Foodservice Products, Inc.**  
 FORT WAYNE, INDIANA  
 IMPINGER II ADVANTAGE 2000

- M4 - MOTOR, BURNER BLOWER
- M5 - MOTOR, CONVEYOR
- S1 - SWITCH, MAIN POWER
- S2 - SWITCH, CONVEYOR REVERSING
- T1 - THERMOSTAT, HI LIMIT CTRL BOX
- T2 - THERMOSTAT, COOLING FAN
- TC - THERMOCOUPLE, TYPE K
- V1 - VALVE, TEMPERATURE REGULATION
- V2 - VALVE, DUAL SAFETY
- XR1 - TRANSFORMER, CONTROL
- XR2 - TRANSFORMER, BURNER
- (XX) - WIRE NUMBERS

- BC - BURNER CONTROL
- C1 - CAPACITOR, MAIN FAN MOTOR
- C2 - CAPACITOR, CONVEYOR MOTOR
- CON - CONTROL, OVEN
- CS1 - SWITCH, MAIN FAN CENT.
- CS2 - SWITCH, BURNER BLOWER CENT.
- F1 - FUSE, MOTOR & CONTROLS, 10A
- F5 - FLAME SENSOR
- H1 - HALL EFFECT SENSOR
- H5 - HOT SURFACE IGNITER
- M1 - MAGNET
- M2, M3 - MOTOR, MAIN FAN
- M4 - MOTOR, COOLING FAN

28064571

# SCHEMATIC DIAGRAM

## MODEL 1130-080-A, 1130-080-A1, 1131-080-A, 1131-080-A1

### S/N 0809210000016 AND BELOW

**Lincoln**  
Foodservice Products, Inc.  
FORT WAYNE, INDIANA  
Impinger, II

2805563

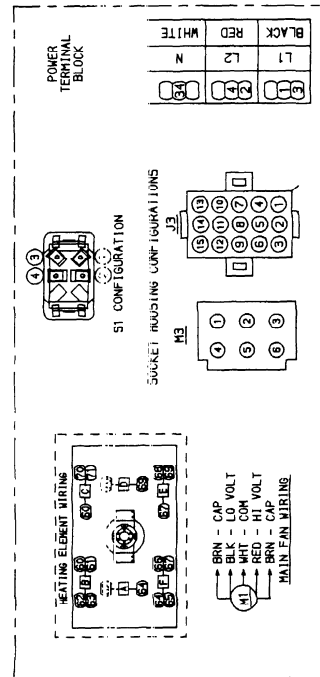
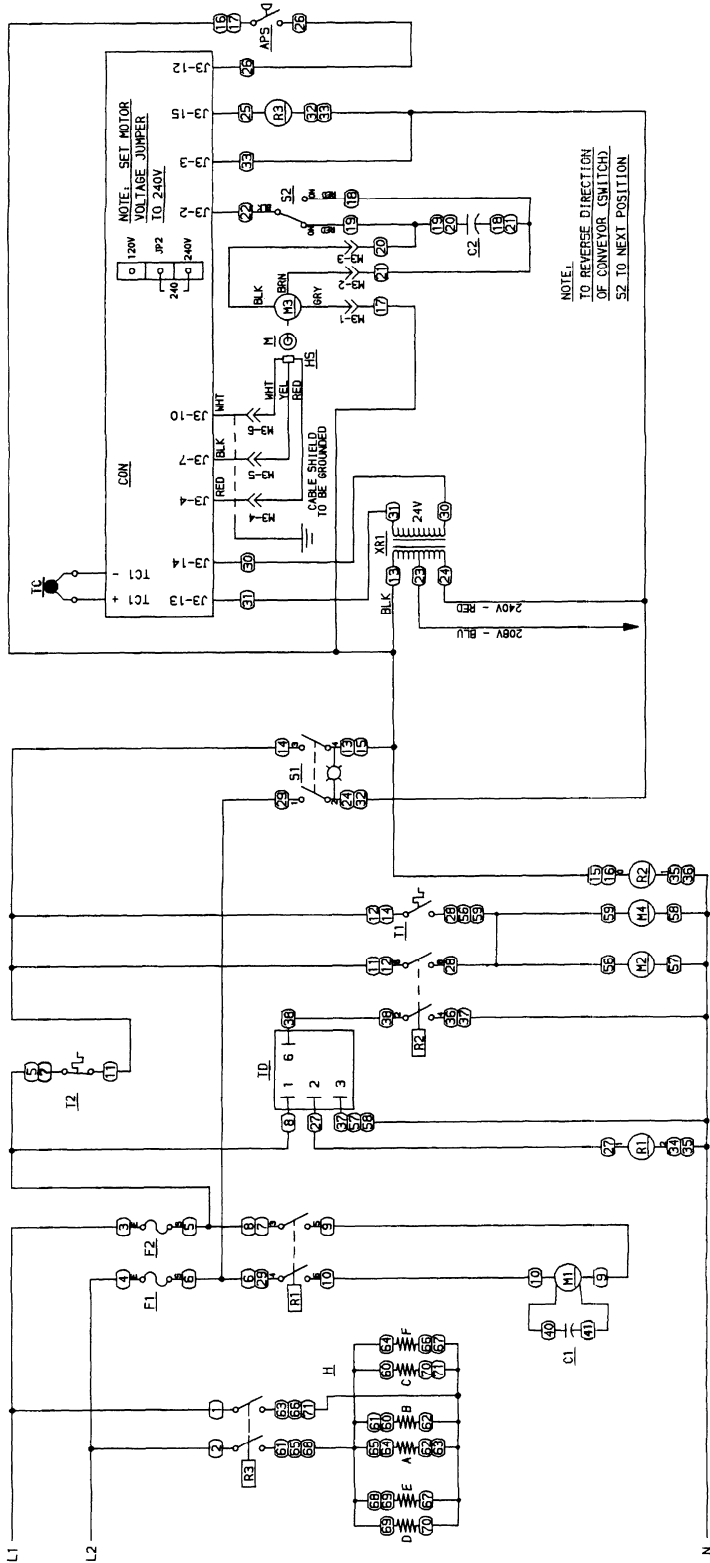

- R2 - RELAY, OVEN START & COOL DOWN
- R3 - RELAY, WATER POWER
- S1 - SWITCH, CONVEYOR REVERSING
- S2 - SWITCH, CONVEYOR REVERSING
- T1 - THERMOSTAT, CONTROL BOX COOLING
- T2 - THERMOSTAT, HIGH LIMIT, OVEN
- T3 - THERMOCOUPLE, TYPE K, 20 MINUTES
- IC - THERMOCOUPLE, CONTROL
- X1 - TRANSFORMER, CONTROL
- (XX) - WIRE NUMBERS

- APS - AIR PRESSURE SWITCH
- C1 - CAPACITOR, CONVEYOR MOTOR
- CON - CONTROL, CONVEYOR MOTOR
- F1, F2 - FUSE, FAN MOTOR 10A
- H - HEATING ELEMENTS 1600W (6 PK5)
- H5 - HALL EFFECT SENSOR
- M1 - MOTOR, OVEN FAN
- M2, M4 - MOTOR, COOLING FAN
- M3 - MOTOR, CONVEYOR
- R1 - RELAY, OVEN FAN MOTOR

# SCHEMATIC DIAGRAM

## MODEL 1132-080-A, 1132-080-A1, 1133-080-A, 1133-080-A1 S/N 0809210000016 AND BELOW

**Lincoln**  
Foodservice Products, Inc.  
FORT WAYNE, INDIANA  
Impinger II

2806562

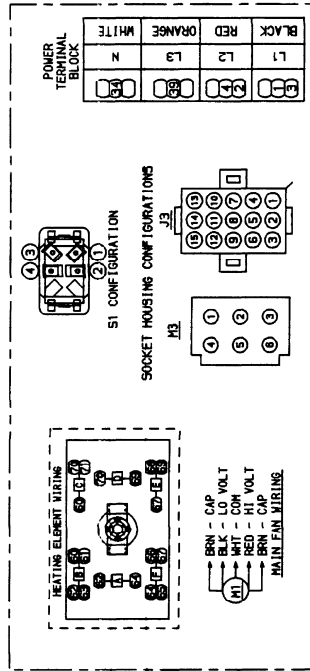
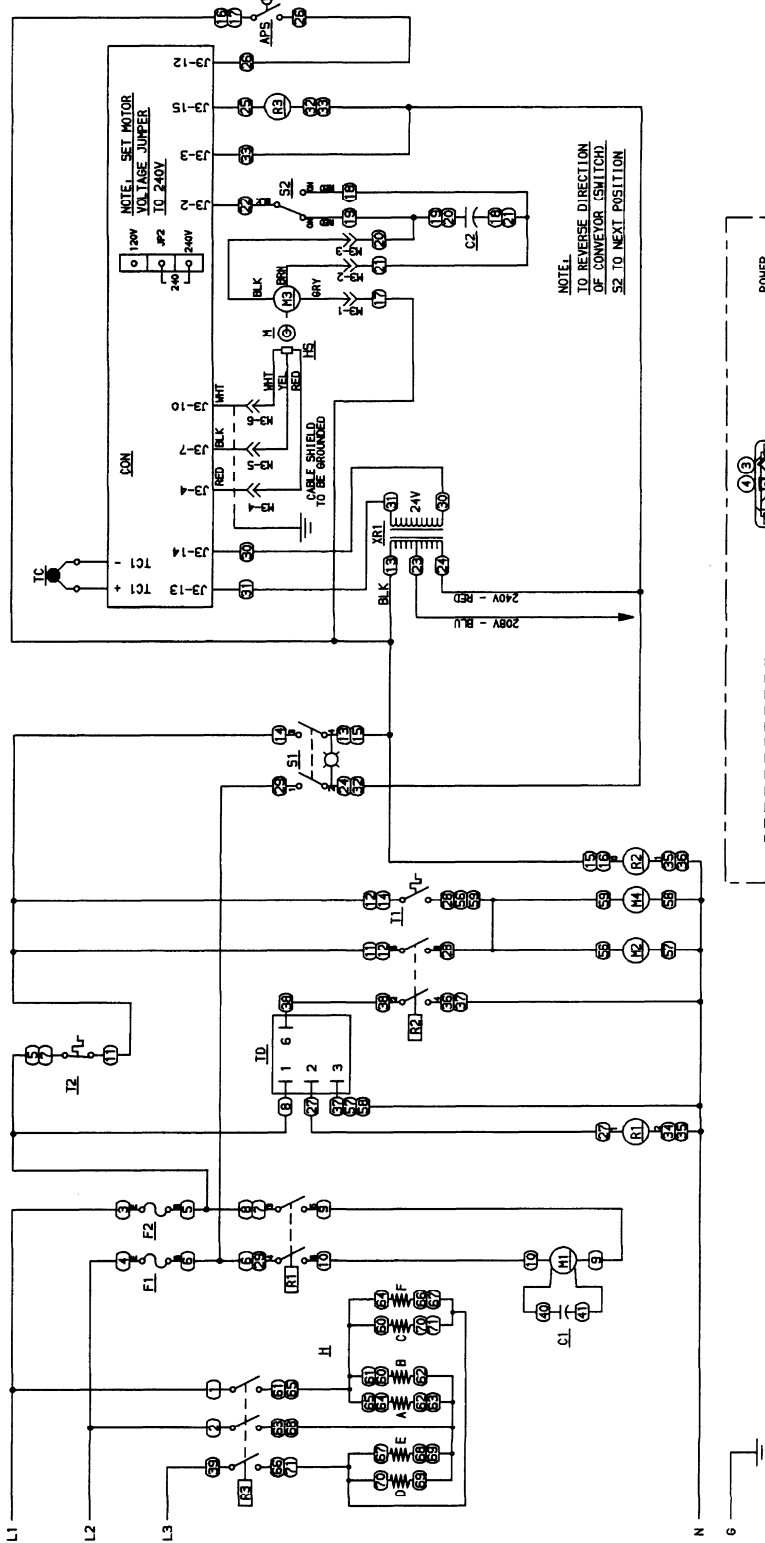

- R2 - RELAY, OVEN START & COOL DOWN
- R3 - RELAY, HEATERS
- S1 - SWITCH, MAIN POWER
- S2 - SWITCH, CONVEYOR POWER REVERSING
- T1 - THERMISTAT, CONTROL BOX COOLING
- T2 - THERMISTAT, HIGH LIMIT, OVEN
- TC - THERMOCOUPLE, TYPE K
- ID - TIMER DELAY, 20 MINUTES
- H1 - MAGNET OVEN FAN
- H2, H4 - MOTOR, COOLING FAN
- H3 - MOTOR, CONVEYOR
- R1 - RELAY, OVEN FAN MOTOR

- APS - AIR PRESSURE SWITCH
- C1 - CAPACITOR, 7.5 MFD
- CON - CONTROL, CONVEYOR MOTOR
- F1, F2 - FUSE, FAN MOTOR, 10A
- H - HEATING ELEMENTS 1600W (6 PCS)
- H1 - HALL EFFECT SENSOR
- M1 - MAGNET OVEN FAN
- M2, M4 - MOTOR, COOLING FAN
- M3 - MOTOR, CONVEYOR
- R1 - RELAY, OVEN FAN MOTOR



# SCHEMATIC DIAGRAM MODEL 1161-080-A S/N 080921000016 AND BELOW

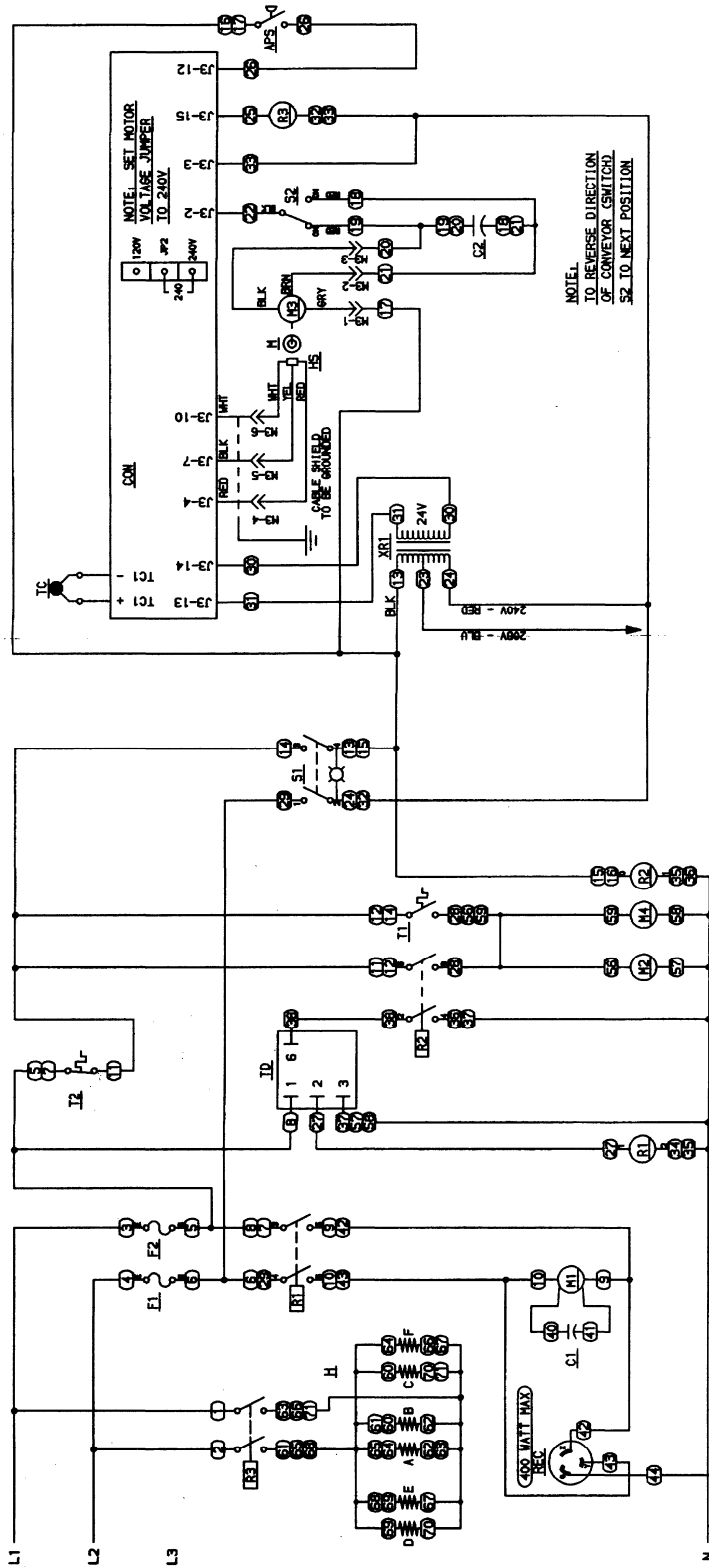

- APS - AIR PRESSURE SWITCH
- C1 - CAPACITOR, 7.5 MFD
- C2 - CAPACITOR, CONVEYOR MOTOR
- CON - CONTROL, OVEN
- F1, F2 - FUSE, FAN MOTOR, 10A
- H - HEAT SENSITIVE THERMIST, OVEN
- H2 - HALL EFFECT SENSOR
- H3 - MAGNET
- H4 - MOTOR, OVEN FAN
- M1, M2, M3 - MOTOR, COOLING FAN
- M4 - MOTOR, OVEN FAN
- R1 - RELAY, OVEN START & COOL DOWN
- R2 - RELAY, HEATERS
- R3 - RECEPTACLE LG-20, 20A, 250V
- S1 - SWITCH, MAIN POWER
- S2 - SWITCH, CONVEYOR REVERSING
- T1 - THERMIST, OVEN
- T2 - THERMIST, OVEN
- T3 - THERMIST, OVEN
- T4 - THERMIST, OVEN
- TC - THERMOCOUPLE, TYPE K
- TD - TIMER DELAY, 20 MINUTES
- X1 - TRANSFORMER, CONTROL
- WIRE NUMBERS

- BRN - CAP VOLT
- BLK - CO VOLT
- RED - HT VOLT
- BRN - CAP
- MAIN FAN WIRING

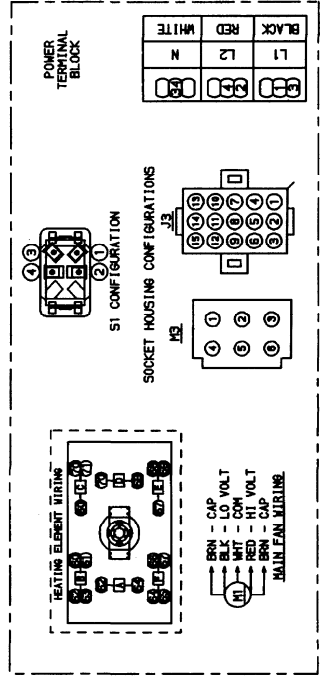

**Lincolm**  
Foodservice Products, Inc.  
FORT WAYNE, INDIANA  
Impinger II

2806465A

# SCHEMATIC DIAGRAM MODEL 1162-080-A S/N 080921000016 AND BELOW

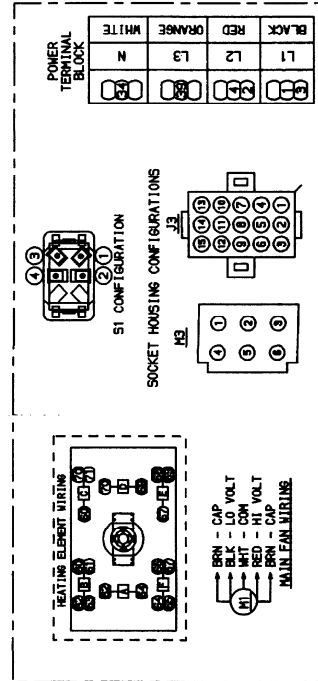
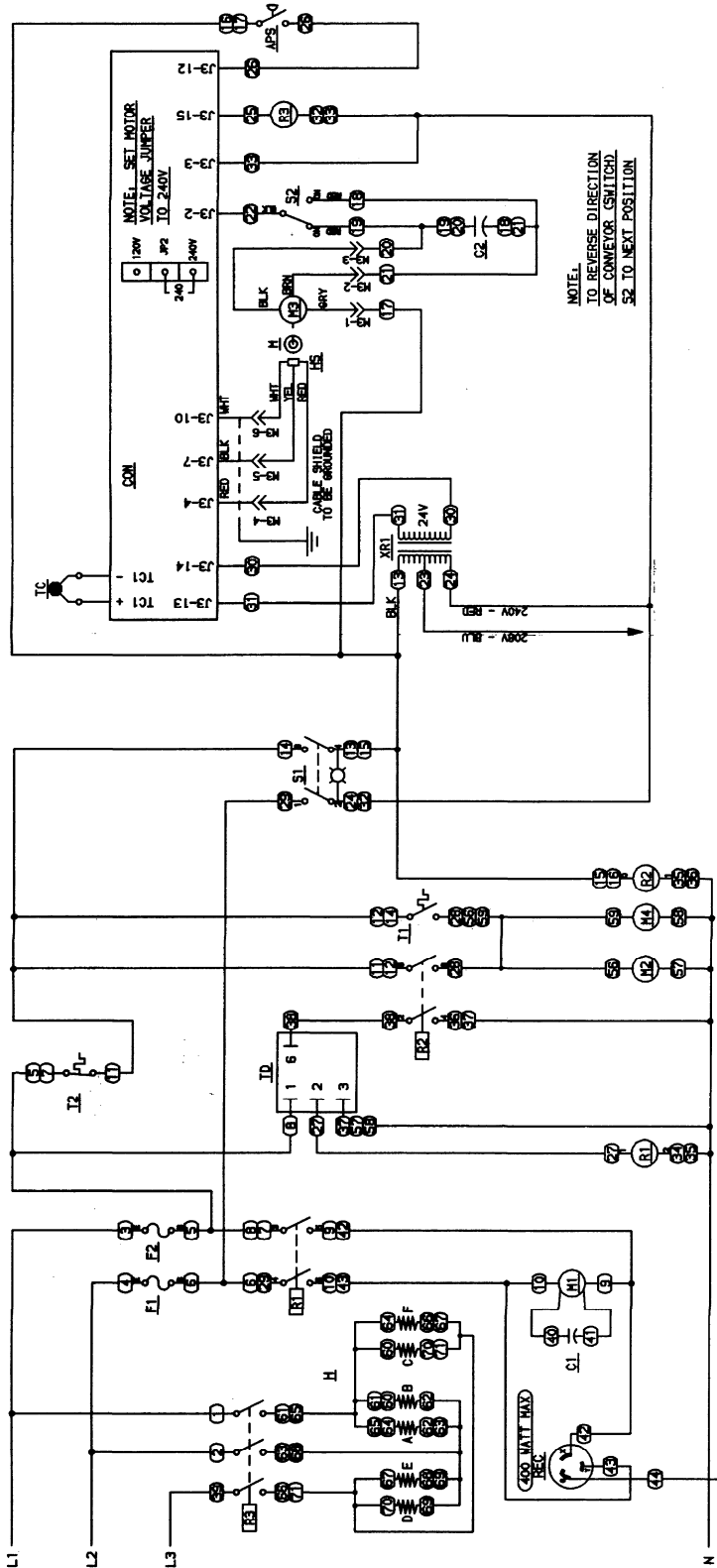

- RELAY, OVEN START & COOL DOWN
- RELAY, HEATERS 20, 20A, 250V
- CAPACITOR, CONVEYOR MOTOR
- SWITCH, MAIN POWER
- SWITCH, CONVEYOR REVERSING
- THERMOSTAT, CONTROL BOX COOLING
- THERMOSTAT, HIGH LIMIT, OVEN
- THERMOCOUPLE, TYPE K, WITES
- TRANSFORMER, CONTROL
- WIRE NUMBERS

- APS - AIR PRESSURE SWITCH
- C1 - CAPACITOR, CONVEYOR MOTOR
- CON - CONTROL, OVEN MOTOR, 10A
- F1, F2 - FUSE, FAN MOTOR, 10A
- H - HEATING ELEMENTS 1500W (6 PCS)
- M1 - MOTOR, OVEN FAN
- M2, M4 - MOTOR, COOLING FAN
- M3 - MOTOR, CONVEYOR
- R1 - RELAY, OVEN FAN MOTOR

**Lincoln**  
Foodservice Products, Inc.  
FORT WAYNE, INDIANA  
Impinger II

2806466A

**SCHEMATIC DIAGRAM**  
**MODEL 1130-08H-A, 1131-08H-A**  
**S/N 080921000016 AND BELOW**

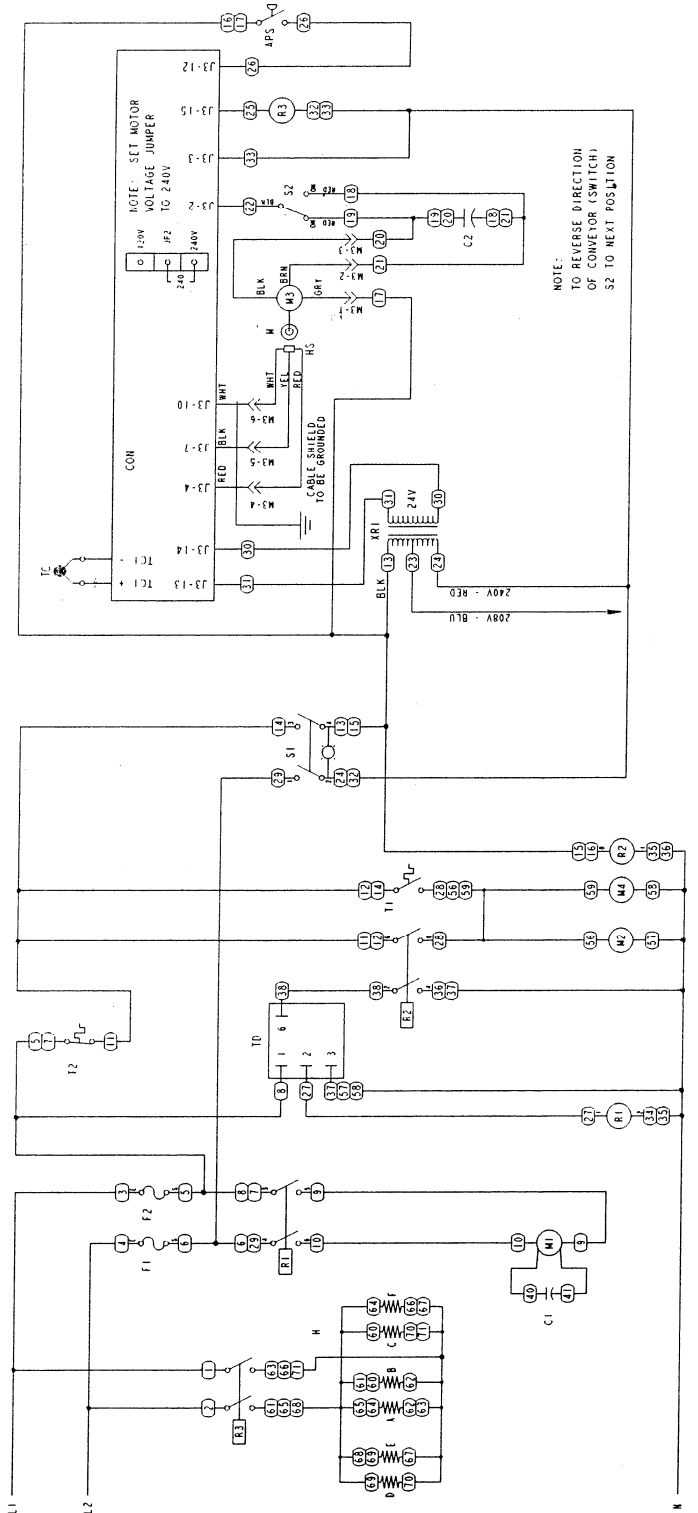

NOTE:  
 TO REVERSE DIRECTION  
 OF CONVEYOR (SWITCH)  
 S2 TO NEXT POSITION

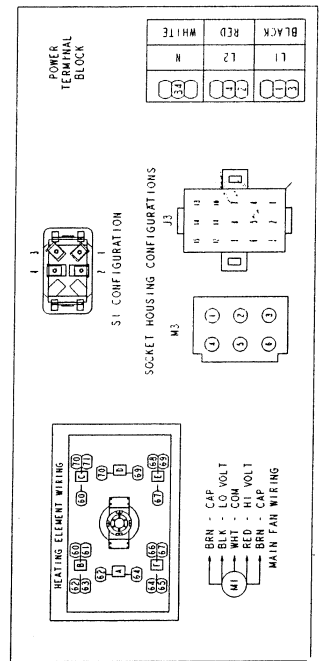

HEATING ELEMENT WIRING

BRN - CAP  
 WHT - COM VOLT  
 RED - HI VOLT  
 BRN - CAP  
 MAIN FAN WIRING

AFS - AIR PRESSURE SWITCH  
 C1 - CAPACITOR, 7.5 MFD  
 C2 - CAPACITOR, CONVEYOR MOTOR  
 COM - COMMON  
 F1, F2 - FUSE, 15A MOTOR, 10A  
 H - HEATING ELEMENTS (6 PCS)  
 HS - HEATING ELEMENTS (6 PCS)  
 M - MOTOR  
 M1 - MOTOR, OVEN FAN  
 M2, M4 - MOTOR, CONVEYOR  
 M3 - MOTOR, OVEN FAN  
 R1 - RELAY, OVEN FAN

R2 - RELAY, OVEN START & COOL DOWN  
 R3 - RELAY, HEATERS  
 S1 - SWITCH, MAIN POWER  
 S2 - SWITCH, CONVEYOR REVERSING  
 S3 - SWITCH, OVEN FAN  
 T2 - THERMOSTAT, HIGH LIMIT, OVEN  
 TD - THERMOCOUPLE, TYPE K  
 T0 - THERMOCOUPLE, TYPE K  
 T1 - THERMOCOUPLE, TYPE K  
 T2 - THERMOCOUPLE, TYPE K  
 T3 - THERMOCOUPLE, TYPE K  
 T4 - THERMOCOUPLE, TYPE K  
 T5 - THERMOCOUPLE, TYPE K  
 T6 - THERMOCOUPLE, TYPE K  
 T7 - THERMOCOUPLE, TYPE K  
 T8 - THERMOCOUPLE, TYPE K  
 T9 - THERMOCOUPLE, TYPE K  
 T10 - THERMOCOUPLE, TYPE K  
 T11 - THERMOCOUPLE, TYPE K  
 T12 - THERMOCOUPLE, TYPE K  
 T13 - THERMOCOUPLE, TYPE K  
 T14 - THERMOCOUPLE, TYPE K  
 T15 - THERMOCOUPLE, TYPE K  
 T16 - THERMOCOUPLE, TYPE K  
 T17 - THERMOCOUPLE, TYPE K  
 T18 - THERMOCOUPLE, TYPE K  
 T19 - THERMOCOUPLE, TYPE K  
 T20 - THERMOCOUPLE, TYPE K  
 T21 - THERMOCOUPLE, TYPE K  
 T22 - THERMOCOUPLE, TYPE K  
 T23 - THERMOCOUPLE, TYPE K  
 T24 - THERMOCOUPLE, TYPE K  
 T25 - THERMOCOUPLE, TYPE K  
 T26 - THERMOCOUPLE, TYPE K  
 T27 - THERMOCOUPLE, TYPE K  
 T28 - THERMOCOUPLE, TYPE K  
 T29 - THERMOCOUPLE, TYPE K  
 T30 - THERMOCOUPLE, TYPE K  
 T31 - THERMOCOUPLE, TYPE K  
 T32 - THERMOCOUPLE, TYPE K  
 T33 - THERMOCOUPLE, TYPE K  
 T34 - THERMOCOUPLE, TYPE K  
 T35 - THERMOCOUPLE, TYPE K  
 T36 - THERMOCOUPLE, TYPE K  
 T37 - THERMOCOUPLE, TYPE K  
 T38 - THERMOCOUPLE, TYPE K  
 T39 - THERMOCOUPLE, TYPE K  
 T40 - THERMOCOUPLE, TYPE K  
 T41 - THERMOCOUPLE, TYPE K  
 T42 - THERMOCOUPLE, TYPE K  
 T43 - THERMOCOUPLE, TYPE K  
 T44 - THERMOCOUPLE, TYPE K  
 T45 - THERMOCOUPLE, TYPE K  
 T46 - THERMOCOUPLE, TYPE K  
 T47 - THERMOCOUPLE, TYPE K  
 T48 - THERMOCOUPLE, TYPE K  
 T49 - THERMOCOUPLE, TYPE K  
 T50 - THERMOCOUPLE, TYPE K  
 T51 - THERMOCOUPLE, TYPE K  
 T52 - THERMOCOUPLE, TYPE K  
 T53 - THERMOCOUPLE, TYPE K  
 T54 - THERMOCOUPLE, TYPE K  
 T55 - THERMOCOUPLE, TYPE K  
 T56 - THERMOCOUPLE, TYPE K  
 T57 - THERMOCOUPLE, TYPE K  
 T58 - THERMOCOUPLE, TYPE K  
 T59 - THERMOCOUPLE, TYPE K  
 T60 - THERMOCOUPLE, TYPE K  
 T61 - THERMOCOUPLE, TYPE K  
 T62 - THERMOCOUPLE, TYPE K  
 T63 - THERMOCOUPLE, TYPE K  
 T64 - THERMOCOUPLE, TYPE K  
 T65 - THERMOCOUPLE, TYPE K  
 T66 - THERMOCOUPLE, TYPE K  
 T67 - THERMOCOUPLE, TYPE K  
 T68 - THERMOCOUPLE, TYPE K  
 T69 - THERMOCOUPLE, TYPE K  
 T70 - THERMOCOUPLE, TYPE K  
 T71 - THERMOCOUPLE, TYPE K  
 T72 - THERMOCOUPLE, TYPE K  
 T73 - THERMOCOUPLE, TYPE K  
 T74 - THERMOCOUPLE, TYPE K  
 T75 - THERMOCOUPLE, TYPE K  
 T76 - THERMOCOUPLE, TYPE K  
 T77 - THERMOCOUPLE, TYPE K  
 T78 - THERMOCOUPLE, TYPE K  
 T79 - THERMOCOUPLE, TYPE K  
 T80 - THERMOCOUPLE, TYPE K  
 T81 - THERMOCOUPLE, TYPE K  
 T82 - THERMOCOUPLE, TYPE K  
 T83 - THERMOCOUPLE, TYPE K  
 T84 - THERMOCOUPLE, TYPE K  
 T85 - THERMOCOUPLE, TYPE K  
 T86 - THERMOCOUPLE, TYPE K  
 T87 - THERMOCOUPLE, TYPE K  
 T88 - THERMOCOUPLE, TYPE K  
 T89 - THERMOCOUPLE, TYPE K  
 T90 - THERMOCOUPLE, TYPE K  
 T91 - THERMOCOUPLE, TYPE K  
 T92 - THERMOCOUPLE, TYPE K  
 T93 - THERMOCOUPLE, TYPE K  
 T94 - THERMOCOUPLE, TYPE K  
 T95 - THERMOCOUPLE, TYPE K  
 T96 - THERMOCOUPLE, TYPE K  
 T97 - THERMOCOUPLE, TYPE K  
 T98 - THERMOCOUPLE, TYPE K  
 T99 - THERMOCOUPLE, TYPE K  
 T100 - THERMOCOUPLE, TYPE K

**Lincoln**  
 Foodservice Products, Inc.  
 FORT WAYNE, INDIANA  
 Impinger II

2806563B

**SCHEMATIC DIAGRAM  
MODEL 1132-08H-A, 1133-08H-A  
S/N 080921000016 AND BELOW**

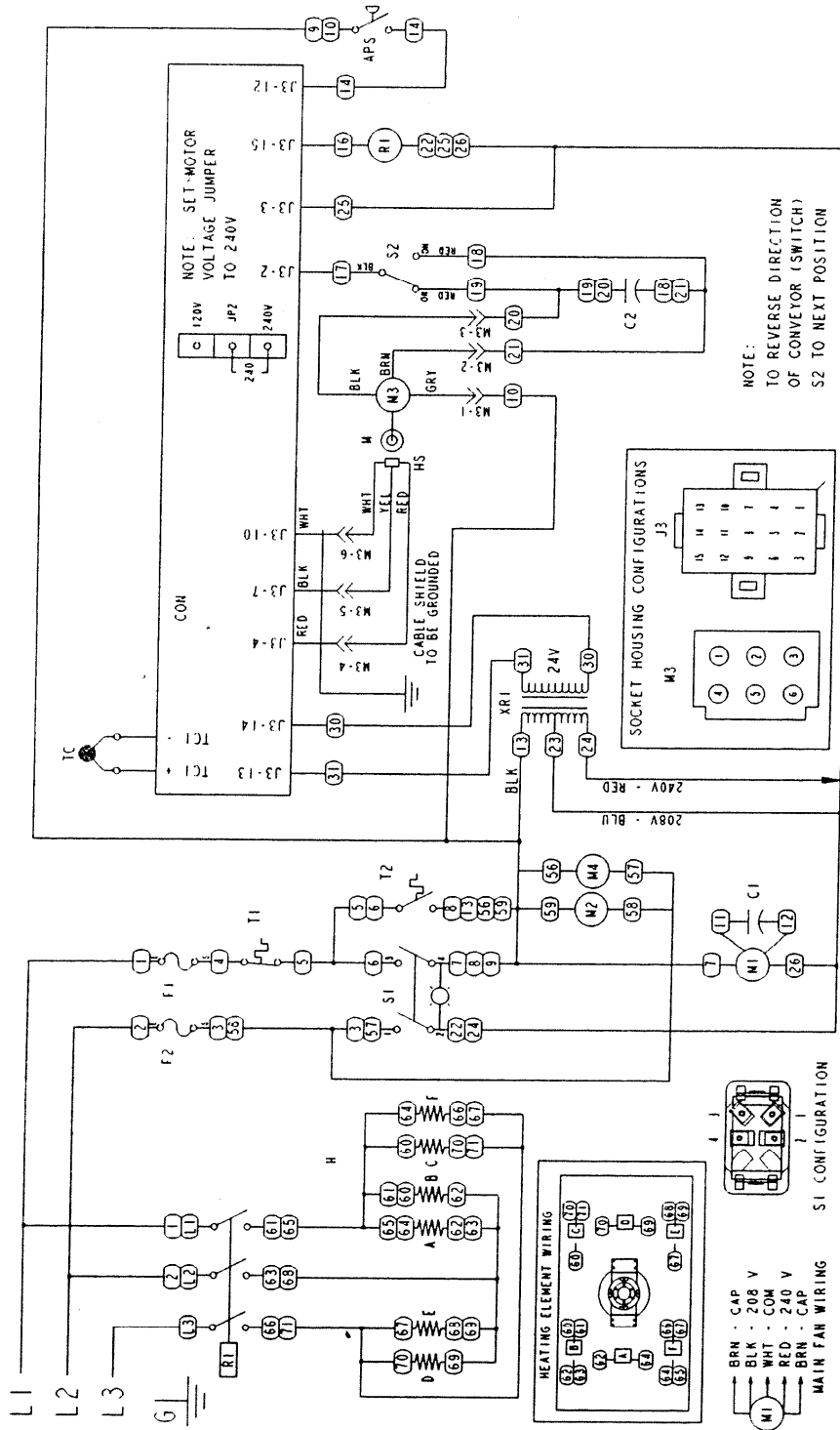

**Lincoln**  
Foodservice Products, Inc.  
FORT WAYNE, INDIANA  
IMPINGER II ADVANTAGE

- M3 - MOTOR, CONVEYOR
- M4 - MOTOR, COOLING FAN
- R1 - RELAY, HEATER
- S1 - SWITCH, MAIN POWER
- S2 - SWITCH, CONVEYOR REVERSING
- T1 - THERMOSTAT, OVEN HI LIMIT
- T2 - THERMOSTAT, COOLING FAN
- TC - THERMOCOUPLE, TYPE K
- XRI - TRANSFORMER, CONTROL
- (XX) - WIRE NUMBERS

- APS - AIR PRESSURE SWITCH
- C1 - CAPACITOR, MAIN FAN
- C2 - CAPACITOR, CONVEYOR MOTOR
- CON - CONTROL, OVEN DIGITAL
- F1, F2 - FUSE, MOTOR & CONTROLS, 10A
- H - HALL EFFECT SENSOR
- H - HEATER
- M - MAGNET
- M1 - MOTOR, MAIN FAN
- M2 - MOTOR, COOLING FAN

2806638A

# SCHEMATIC DIAGRAM ALL MODELS S/N 080921000017 AND ABOVE

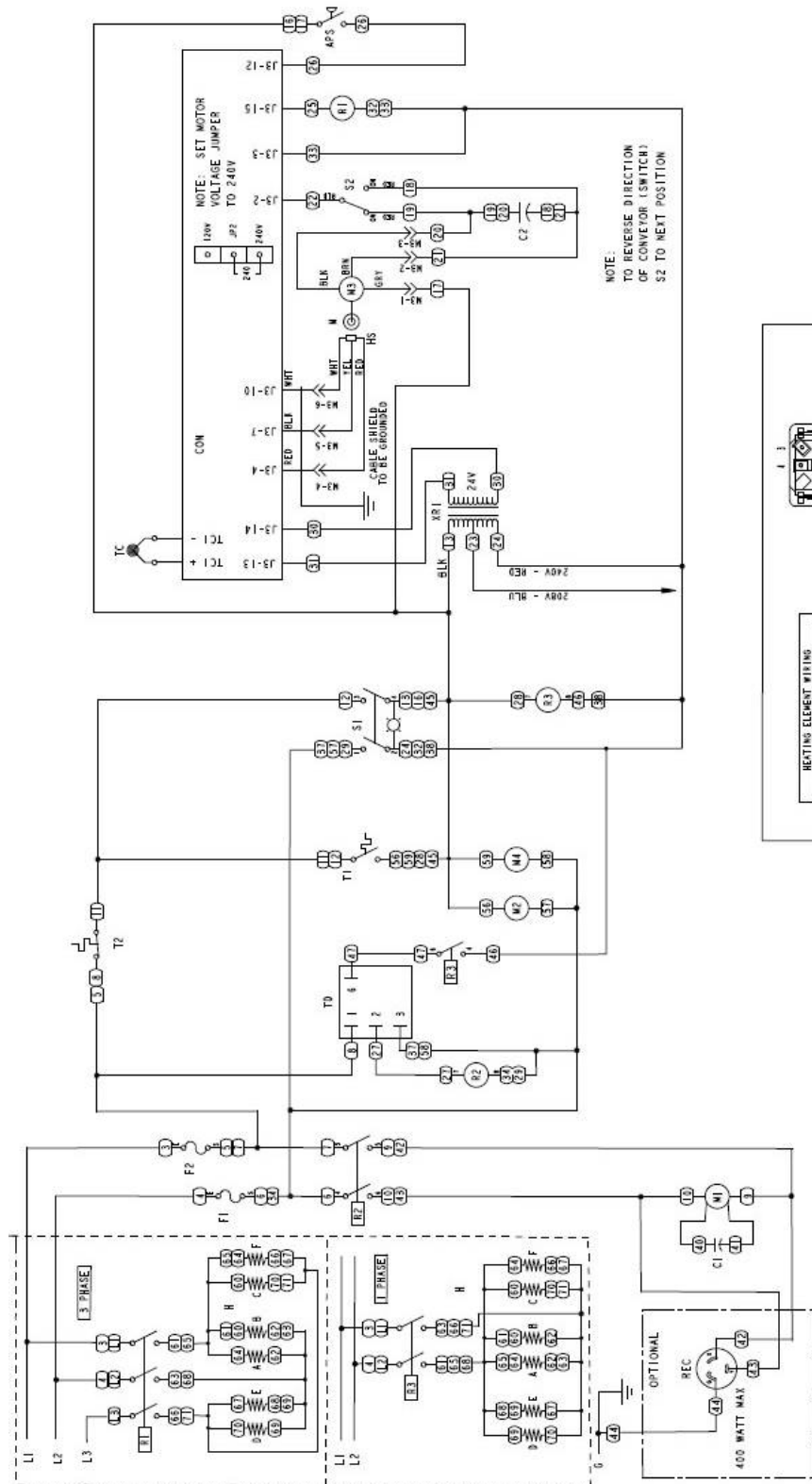

- R1 - RELAY, HEATERS
- R2 - RELAY, OVEN FAN MOTOR
- REC - RECEPTICAL (OPTIONAL)
- REC - CONTROL, OVEN MOTOR
- S1 - SWITCH, MAIN POWER (OVERHEATING)
- S2 - SWITCH, MAIN POWER (OVERHEATING)
- T1 - THERMOSTAT, CONTROL BOX COOLING
- T2 - THERMOSTAT, HIGH LIMIT, OVEN
- TC - THERMOCOUPLE, TYPE K
- TD - TIMER DELAY, 20 MINUTES
- TI - THERMISTANCE CONTROL
- (W) - WIRE NUMBERS

- APS - AIR PRESSURE SWITCH
- C1 - CAPACITOR, 7.5 MFD
- CON - CONTROL, CONVEYOR MOTOR
- H - HEATING ELEMENTS (10A)
- H1, F2 - HEATING ELEMENTS (10A)
- M - BALL EFFECT SENSOR
- M1 - MAGNET
- M2, M4 - MOTOR, OVEN FAN
- M3 - MOTOR, COOLING FAN
- M5 - MOTOR, CONVEYOR

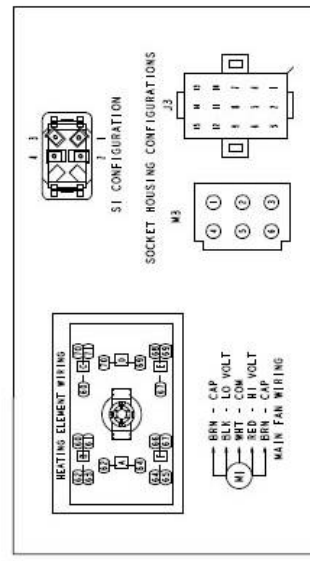

**Lincoln**  
Foodservice Products, Inc.  
FORT WAYNE, INDIANA  
Impinger II

2806562D

## TROUBLESHOOTING GUIDE GAS OVENS

Old Model Number	→	New Model Number	Gas Type	Voltage	Hz.	Phase
1116-080-A (or A1)	→	1116-00z-U-Kxxxx	Natural Gas	120 VAC	60 Hz.	1
1116-062-8R	→	1116-00z-U-Kxxxx	Natural Gas	120 VAC	60 Hz.	1
1116-023-8	→	1116-00z-U-Kxxxx	Natural Gas	120 VAC	60 Hz.	1
1117-080-A (or A1)	→	1117-00z-U-Kxxxx	LP Gas	120 VAC	60 Hz.	1
1117-023-8	→	1117-00z-U-Kxxxx	LP Gas	120 VAC	60 Hz.	1

SYMPTOM	POSSIBLE CAUSE	EVALUATION
Oven fan will not run	Incoming power supply	Check circuit breakers, reset if required. Check power plug to be sure it is firmly in receptacle. Measure incoming power, call power co. if needed.
	Fuse, 10 Amp	Check, replace if necessary.
	Fuse holder	Check, replace if necessary.
	Hi-limit thermostat, control box	Check for voltage on both sides of switch. Terminals are normally closed. If open, reset and test oven for proper operation. If thermostat will not hold, and control box temperature is not exceeding 140°F (60°C), replace thermostat.
	Switch, main power	Check continuity between switch terminals. Replace switch as needed.
	Main fan motor	Check for 120VAC at motor. If no voltage is present, trace wiring back to main power switch. WITH POWER OFF: Check for opens, shorts or grounds. Turn fan blade to check for locked rotor.
No control box cooling	Capacitor	Check for shorts or grounds. WARNING: Capacitor has a stored charge, discharge before testing.
	Incoming power	Check circuit breakers, reset if required. Check power plug to be sure it is firmly in receptacle. Measure incoming power, call power co. if needed.
	Switch, main power	Check continuity between switch terminals. Replace switch as needed.
No automatic control box cooling	Cooling fan	Check for 120VAC at cooling fan. If no voltage is present, trace wiring back to power switch. If voltage is present, and motor does not run, check for opens, shorts or grounds. WITH POWER OFF: Check for locked rotor.
	Incoming power supply	Check circuit breakers, reset if required. Check power plug to be sure it is firmly in receptacle. Measure incoming power, call power co. if needed.
	Cooling fan thermostat	Check the cooling fan thermostat. (Thermostat closes at 120°F and opens at 100°F). With the cooling fan thermostat pre-heated, check for continuity. If switch is open, replace cooling fan thermostat.
Oven will not heat	Cooling fan	Check for 120VAC at cooling fan. If no voltage is present, trace wiring back to cooling fan thermostat. If voltage is present, and motor does not run, check for opens, shorts or grounds. WITH POWER OFF: Check for locked rotor.
	Gas supply	Check for adequate gas supply to oven.
	Manual gas shut off valve.	Check to see that the manual gas shut off valve is open. Also check flexible gas line connection for any damage.
	Main fan	If not operating, refer to "Oven fan will not run".

	Centrifugal switch of main fan motor	Check for 120VAC at wire #5 (input to centrifugal switch, located at 6-pin connector in raceway near the main fan motor) to neutral. If no voltage is present, trace wiring back to the main power switch. If voltage is present, check for 120VAC at wire #22 (output of centrifugal switch) to neutral. If no voltage is present at #22, and the motor is running, replace the main fan motor.
	Hi-limit thermostat, oven cavity	Terminals are normally closed. If open, reset thermostat and retest. If thermostat will not hold for maximum oven temperature, and oven is not exceeding temperature setting, check for proper location of capillary bulb in its spring holder. If the capillary checks okay, replace the hi-limit thermostat.
	Burner blower motor	Check for 120VAC supplied to burner blower motor at wire #13 to neutral. If no voltage is present, trace wiring back to the main power switch. If voltage is present, and the motor is not running, check for opens, shorts or grounds. WITH POWER OFF: Turn motor to check for locked rotor.
	Burner transformer	Check for 120VAC supplied to the primary of the burner transformer. If no voltage is present, trace wiring back to the oven cavity hi-limit thermostat. If voltage is present, check for 24VAC at transformer secondary. If there is primary voltage but no secondary voltage, replace burner transformer.
	Centrifugal switch of burner blower motor	Check for 24VAC at motor connector, wire #13 to neutral. If voltage is not present, trace wiring back to transformer. If voltage is present, check for voltage at wire #14 to neutral. If no voltage is present at wire #14, and motor is running, replace burner blower motor.
	Ignition control	Check for 24VAC at ignition control terminals marked "24V", if no voltage is present, trace wiring back to centrifugal switch. Check for 120VAC to ignition control at terminal "L1" to neutral. If no voltage is present, trace wiring back to main power switch. When 24VAC is supplied to the ignition control, the ignition control switches 120VAC to the hot surface igniter. If 24VAC and 120VAC are supplied to ignition control, but there is no voltage at the hot surface igniter, replace the ignition control.
	Hot surface igniter	If 120VAC is present at hot surface igniter terminals, visually check to see that the igniter is heating (igniter may be viewed through the port in the end of burner tube). The igniter should glow bright red. If the igniter does not heat, replace the hot surface igniter.
	Ignition control	After 45 seconds of hot surface igniter pre-heat, the ignition control will switch 24VAC to the gas control valves. Check for 24VAC output from ignition control across terminals marked "valve" and "valve gnd". If no voltage is present, replace ignition control.
	Gas control valves	When 24VAC is supplied to the gas control valves, the valve should open. Check for gas pressure at the manifold tap located just before the burner. If there is no pressure, check the incoming gas supply to be sure all manual valves are open and flexible gas hose is properly connected. If gas is present, and the gas control valve is energized, but there is no gas pressure at the burner manifold, replace the gas

		control valves.
Flame will not stay lit	Hot surface igniter	Six seconds after the gas valve opens, ignition must occur. If flame is not detected, the ignition control will shut off and lock out. To reset the ignition control, turn off the power switch for 45 seconds, then turn the switch on to re-try ignition. The ignition control requires a minimum of 0.8 DC microamps to prove flame. To check flame sensing operation, connect a digital multimeter (capable of measuring DC microamps) between the "ground" terminal on ignition control and the ground lead. NOTE: This is a current measurement and the meter must be connected in series If these readings are not achieved, replace hot surface igniter. NOTE: The DC microamp test must be conducted with the oven in low flame (bypass) operation. Set the temperature control to the lowest setting.
	Power supply	If there is sufficient microamp current, but the flame will not stay lit, check for proper polarity of the 120VAC power supply.
	Ignition control	If there is sufficient microamp current, and the 120VAC polarity is correct, but the flame will not stay lit, replace the ignition control. NOTE: Check for proper ground connection on ignition control.
	NOTE: Flame should be on at this time	
Low flame is on, but no main flame	Control transformer	Check for 120VAC supply to the primary of the control transformer. If no voltage is present, trace wiring back to the main power switch. If voltage is present, check for 24VAC at the transformer secondary. If there is primary voltage, but no secondary voltage, replace the control transformer.
	Oven control	Check for 24VAC supply to control. If no voltage is present, trace wiring back to control transformer. If 24VAC is present, check for a read-out on the display. If there is 24VAC supplied, but there is no read-out on the control display, replace the oven control. If there is a read-out on the control, set the control to maximum temperature (see installation operations manual for temperature adjustment). With the control set at maximum temperature, check for 120VAC at the temperature regulation valve. If there is voltage at the temperature regulation valve, proceed to "Temperature regulation valve" for next check. If there is no voltage at the temperature regulation valve, trace wiring back to the oven control. If there is no voltage output at the oven control, check the read-out on the control. If the control reads "PROBE FAIL", this indicates that the thermocouple has failed or become disconnected from the oven control.
	Thermocouple	Check to be sure that the thermocouple is securely connected to the oven control. If the thermocouple is connected to the oven control, and the control indicates "PROBE FAIL", disconnect the thermocouple from the oven control and measure the resistance of the thermocouple. The thermocouple should read approx. 11Ω. If these readings are not



		achieved, replace the thermocouple. If these readings are correct, proceed.
	Oven control	If the thermocouple checks good, but the oven control display indicates that there is a thermocouple failure, replace the oven control. If the oven control indicates a temperature reading but the oven won't heat, proceed.
	Thermocouple	WITH POWER ON AND THERMOCOUPLE ATTACHED TO THE OVEN CONTROL: Measure the DC millivolt output of the thermocouple. Refer to the thermocouple chart (located in the "Removal" section of the manual) for proper millivolt readings. If these readings are not achieved, replace thermocouple.
	Oven control	If the thermocouple checks good, but there is no 120VAC output to the temperature regulation valve, replace the oven control. If there is 120VAC output to the temperature regulation valve, proceed.
	Temperature regulation valve	Check for 120VAC supplied to temperature regulation valve. If voltage is present, listen for valve to open and close. Also check for opens or shorts in the operating coil. Replace temperature regulation valve as needed.
Intermittent heating	Thermal/overload of main fan and burner blower motors	The main fan motor and burner blower motor are equipped with internal thermal protection and will cease to operate if overheating occurs. As the motors overheat and then cool, this will cause the heating system to cycle on and off intermittently. Improper ventilation or lack of preventive maintenance may cause this problem. Also, most of the problems listed under "Oven will not heat" can cause intermittent failure.
Conveyor will not run	Power supply	Check for incoming voltage at line 1 to neutral. There should be a reading of 120VAC. If not present, check circuit breakers.
	Fuse, 10 Amp	Check, replace if necessary.
	Fuse holder	Check, replace if necessary.
	Hi-limit thermostat, control box	Check for voltage on both sides of switch. Terminals are normally closed. If open, reset and test oven for proper operation. If thermostat will not hold, and control box temperature is not exceeding 140°F (60°C), replace thermostat.
	Power switch	Check continuity between switch terminals. Replace switch as needed.
	Control transformer	Check for 120 VAC supply to the primary of the control transformer. If no voltage is present, trace wiring back to the oven power relay. If voltage is present, check for 24 VAC at the transformer secondary. If there is primary voltage but no secondary voltage, replace control transformer.
	Conveyor motor	Check for 120 VAC supply to the conveyor motor at wire #14 to neutral. If no voltage is present, trace wiring back to the primary of the control transformer. If voltage is present and the motor will not run, check the motor windings for opens or shorts. WITH POWER OFF: Check the motor windings as follows: Grey to black - 38Ω approx. Grey to blue - 38Ω approx. Blue to black - 75Ω approx.

		If any of the above fails, replace conveyor motor.
	Capacitor, conveyor motor	Check for shorts or grounds. Replace capacitor as needed. WARNING: Capacitor has a stored charge, discharge before testing.
	Switch, conveyor reversing	Check continuity between switch terminals. Replace switch as needed.
	Oven control	If there is 120VAC supplied to the motor, and the motor, capacitor, and reversing switch check good, replace the oven control.
Conveyor motor runs, but there is no speed display	NOTE: Display will indicate "Belt Jam"	
	Oven control	Check for output voltage from oven control to hall effect sensor (sensor is located in conveyor motor). Measure voltage at the motor connector, red wire and yellow wire. Voltage should be approx. 10VDC. If no voltage is present, trace wiring back to oven control. If there is no voltage present at the oven control, replace the oven control.
	Conveyor motor	If there is voltage supplied to the hall effect sensor, check for a frequency output from the hall effect sensor. Measure frequency across the yellow and white wires at the motor connector. Frequency reading should be approx. 25 – 100 Hz. If these readings are not achieved, replace conveyor motor. If the readings are achieved, proceed.
	Oven control	If the hall effect sensor readings are correct, but there is no speed indicated on the display, replace the oven control.

## TROUBLESHOOTING GUIDE ELECTRIC OVENS

Old Model Number	→	New Model Number	Voltage	Hz.	Phase
1130-080-A (or A1)	→	1130-00z-U-Kxxxx	208	60 Hz.	1
1130-08H-A	→	N/A	208	60 Hz.	1
1131-080-A (or A1)	→	1131-00z-U-Kxxxx	240	60 Hz.	1
1131-08H-A	→	N/A	240	60 Hz.	1
1132-080-A (or A1)	→	1132-00z-U-Kxxxx	208	60 Hz.	3
1132-08H-A	→	1172-00z-U-Kxxxx	208	60 Hz.	3
1132-002-8	→	1174-00z-U-Kxxxx	208	50/60 Hz.	3
1132-023-8	→	1132-00z-U-Kxxxx	208	50/60 Hz.	3
1133-080-A (or A1)	→	1133-00z-U-Kxxxx	240	60 Hz.	3
1133-08H-A	→	1173-00z-U-Kxxxx	240	60 Hz.	3
1161-080-A	→	1131-00z-U-Kxxxx	240	60 Hz.	1
1162-080-A	→	1132-00z-U-Kxxxx	208	60 Hz.	3
N/A	→	1178-00z-U-Kxxxx	120	60 Hz.	3

SYMPTOM	POSSIBLE CAUSE	EVALUATION
Oven fan will not run	Incoming power supply	Check circuit breakers. Reset if required. Call power co. if needed.
	Fuses, 10 Amp, motor and controls	Check, replace if necessary.
	Fuse holder	Check, replace if necessary.
	Hi-limit thermostat, Oven cavity	Terminals are normally closed. If open, reset thermostat and retest. If thermostat will not hold for maximum oven temperature, and oven is not exceeding temperature setting, check for proper location of capillary bulb in its spring holder. If the capillary checks okay, replace the hi-limit thermostat.
	Switch, main power	Check continuity between switch terminals. Replace switch as needed.
	Relay, oven start	Check for 208 or 240VAC supplied to coil of relay. If no voltage is present, trace wiring back to main power switch. If voltage is present, check for pull in of relay contacts. Replace relay as needed.
	20 minute time delay	Check for 208 or 240VAC at terminal #1 to L2 on time delay relay. If voltage is not present, trace wiring back to 10A fuse. If voltage is present at terminal #1, check for 208/240VAC at terminal #2 to L2. If no voltage is present, and oven start relay is closed, replace 20 minute time delay relay.
	Relay, main fan	Check for 208 or 240VAC to coil of main fan relay. If no voltage is present, trace wiring back to 20 minute time delay relay. If voltage is present, check to insure that relay contacts are closing. Replace relay as needed.
	Main fan motor	Check for supply voltage at motor. If no voltage is present, trace wiring back to main fan relay. WITH POWER OFF: Check for opens, shorts or grounds. Turn fan blade to check for locked rotor.
No main fan cool down	Capacitor	Check for shorts or grounds. WARNING: Capacitor has a stored charge, discharge before testing.
	20 Minute time delay	Check for 208 or 240VAC at terminal #2 to neutral while the oven is 'on'. Turn off the main switch, 208 or 240VAC should continue to be present for 20 minutes. If voltage is not present for approx. 20

		minutes, replace the 20 minute time delay.
	Oven fan relay	Check for 208 or 240VAC to relay coil, if no voltage is present, trace wiring back to 20 minute time delay. If voltage is present, be sure that relay contacts stay closed during the 20 minute cool down. Replace relay as needed.
Main fan runs after 20 minute cool down	Oven start relay	Contacts should open when main power switch is turned off. Replace relay as needed.
	20 Minute time delay	208 or 240VAC at terminal #2 should discontinue approx. 20 minutes after main power is switched off. If the oven start relay contacts are open, and the voltage continues at terminal #2 of the 20 minute timer, for more than 20 minutes, replace the 20 minute time delay.
	Oven fan relay	Check to insure that the relay contacts are opening after the relay coil is de-energized. Replace relay as needed.
	20 Minute time delay	NOTE: On/ off operation of the main power switch will set the timer to 20 minutes. If the timer is accidentally reset, turn off the main circuit breaker for 15 seconds to cancel.
No control box cooling	Incoming power	Check circuit breakers, reset if required. Check power plug to be sure it is firmly in receptacle. Measure incoming power, call power co. if needed.
	Switch, main power	Check continuity between switch terminals. Replace switch as needed.
	Cooling fan	Check for supply voltage at cooling fan. If no voltage is present, trace wiring back to power switch. If voltage is present, and motor does not run, check for opens, shorts or grounds. WITH POWER OFF: Check for locked rotor.
No automatic control box cooling	Incoming power supply	Check circuit breakers, reset if required. Check power plug to be sure it is firmly in receptacle. Measure incoming power, call power co. if needed.
	Cooling fan thermostat	Check the cooling fan thermostat. (Thermostat closes at 120°F and opens at 100°F). With the cooling fan thermostat pre-heated, check for continuity. If switch is open, replace cooling fan thermostat.
	Cooling fan	Check for supply voltage at cooling fan. If no voltage is present, trace wiring back to cooling fan thermostat. If voltage is present, and motor does not run, check for opens, shorts or grounds. WITH POWER OFF: Check for locked rotor.
Oven will not heat	Main fan motor	Check for main fan operation. If it is not operating, refer to "Oven fan will not run".
	Air pressure switch	This normally open switch should close when the main fan is activated. Refer to the "Removal and installation" section for proper adjustment. Replace as needed.
	Control transformer	Check for 208 or 240VAC supply to the primary of the control transformer. If no voltage is present, trace wiring back to the main power switch. If voltage is present, check for 24VAC at the transformer secondary. If there is primary voltage, but no secondary voltage, replace the control transformer.
	Oven control	Check for 24VAC supply to control. If no voltage is

		<p>present, trace wiring back to control transformer. If 24VAC is present, check for a read-out on the display. If there is 24VAC supplied, but there is no read-out on the control display, replace the oven control.</p> <p>If there is a read-out on the control, set the control to maximum temperature (see installation operations manual for temperature adjustment). With the control set at maximum temperature, check for supply voltage at mercury contactor. If there is voltage at the mercury contactor, proceed to “mercury contactor” for next check. If there is no voltage at the mercury contactor, trace wiring back to the oven control. If there is no voltage output at the oven control, check the read-out on the control. If the control reads “PROBE FAIL”, this indicates that the thermocouple has failed or become disconnected from the oven control.</p>
	Thermocouple	<p>Check to be sure that the thermocouple is securely connected to the oven control. If the thermocouple is connected to the oven control, and the control indicates “PROBE FAIL”, disconnect the thermocouple from the oven control and measure the resistance of the thermocouple. The thermocouple should read approx. 11Ω. If these readings are not achieved, replace the thermocouple. If these readings are correct, proceed.</p>
	Oven control	<p>If the thermocouple checks good, but the oven control display indicates that there is a thermocouple failure, replace the oven control. If the oven control indicates a temperature reading but the oven will not heat, proceed.</p>
	Thermocouple	<p>WITH POWER ON AND THERMOCOUPLE ATTACHED TO THE OVEN CONTROL: Measure the DC millivolt output of the thermocouple. Refer to the thermocouple chart (located in the “Removal” section of the manual) for proper millivolt readings. If these readings are not achieved, replace thermocouple.</p>
	Oven control	<p>If the thermocouple checks good, but there is no voltage output to the mercury contactor, replace the oven control. If there is voltage output to the mercury contactor, proceed.</p>
	Mercury contactor	<p>Check for supply voltage to the contactor coil. If voltage is present and the contactor will not activate, replace the mercury contactor. Also check each contactor for high voltage input and output.</p>
	Heating element(s)	<p>Check the Amp draw on each power leg for proper load. Check the specification plate for rating information. If the amp draw is high or low, check the individual elements for opens, shorts and proper resistance.</p> <p>WITH POWER OFF: To check resistance of the elements, remove all leads from the elements and use a digital multimeter.</p> <p>The element resistance is should be as follows:  208V – 27 ohms approx.  240V – 36 ohms approx.</p> <p>Replace heating elements as needed.</p>

Oven heats with switch off	Mercury contactor	The mercury contactor has probably failed in the closed position. If there is no voltage to the operating coil, but there is high voltage at the contactor output, replace the mercury contactor.
Intermittent heating	Thermal/overload of motor	The main fan motor is equipped with internal thermal protection and will cease to operate if overheating occurs. As the motor overheats and then cools, this will cause the oven to cycle on and off intermittently. Improper ventilation or lack of preventive maintenance may cause this. Also, most of the problems listed under "Oven will not heat" can cause intermittent failure.
Conveyor will not run	Power supply	Check circuit breakers, reset if required. Check power plug to be sure it is firmly in receptacle. Measure incoming power, call power co. if needed.
	Fuse, 10 Amp	Check, replace if necessary.
	Fuse holder	Check, replace if necessary.
	Hi-limit thermostat, oven cavity	Terminals are normally closed. If open, reset thermostat and retest. If thermostat will not hold for maximum oven temperature, and oven is not exceeding temperature setting, check for proper location of capillary bulb in its spring holder. If the capillary checks okay, replace the hi-limit thermostat.
	Power switch	Check continuity between switch terminals. Replace switch as needed.
	Control transformer	Check for supply voltage to the primary of the control transformer. If no voltage is present, trace wiring back to the oven power relay. If voltage is present, check for 24 VAC at the transformer secondary. If there is primary voltage but no secondary voltage, replace control transformer.
	Conveyor motor	Check for supply voltage to the conveyor motor. If no voltage is present, trace wiring back to the primary of the control transformer. If voltage is present and the motor will not run, check the motor windings for opens or shorts. WITH POWER OFF: Check the motor windings as follows: Grey to black - 240Ω approx. Grey to tan - 240Ω approx. Tan to black - 480Ω approx. If any of the above fails, replace conveyor motor.
	Capacitor, conveyor motor	Check for shorts or grounds. Replace capacitor as needed. WARNING: Capacitor has a stored charge, discharge before testing.
	Switch, conveyor reversing	Check continuity between switch terminals. Replace switch as needed.
	Oven control	If there is supply voltage to the motor, and the motor, capacitor, and reversing switch check good, replace the oven control.
Conveyor motor runs, but there is no speed display	NOTE: Display will indicate "Belt Jam"	
	Oven control	Check for output voltage from oven control to hall effect sensor (sensor is located in conveyor motor). Measure voltage at the motor connector,

		red wire and yellow wire. Voltage should be approx. 10VDC. If no voltage is present, trace wiring back to oven control. If there is no voltage present at the oven control, replace the oven control.
	Conveyor motor	If there is voltage supplied to the hall effect sensor, check for a frequency output from the hall effect sensor. Measure frequency across the yellow and white wires at the motor connector. Frequency reading should be approx. 25 – 100 Hz. If these readings are not achieved, replace conveyor motor. If the readings are achieved, proceed.
	Oven control	If the hall effect sensor readings are correct, but there is no speed indicated on the display, replace the oven control.

## REMOVAL, INSTALLATION AND ADJUSTMENTS IMPINGER II ADVANTAGE SERIES

### CAUTION

BEFORE REMOVING OR INSTALLING ANY COMPONENT IN THE IMPINGER OVEN BE SURE TO DISCONNECT ELECTRICAL POWER AND GAS SUPPLY.

#### MAIN FAN – REPLACEMENT

- A. Shut off power at main breaker.
  - B. Remove motor cover from back of oven.
  - C. Disconnect wiring and mark for reassembly.
  - D. Remove bolts and slide back straight out of the oven.
  - E. Loosen the bolt from fan hub and remove fan from motor shaft.
- NOTE: Measure distance from fan blade to rear wall assembly before removal to aid in reassembly.
- F. Reassemble in reverse order and check system operation.

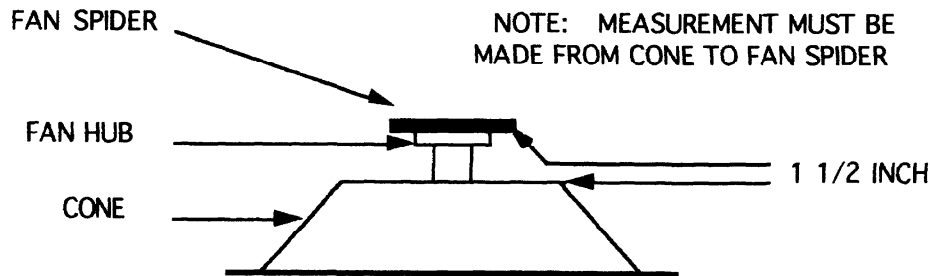

#### MOTOR, MAIN FAN – REPLACEMENT

- A. Shut off power at main breaker.
  - B. Remove motor cover from back of oven.
  - C. Disconnect wiring and mark for reassembly.
  - D. Remove bolts and slide back straight out of the oven.
  - E. Loosen the bolt from fan hub and remove fan from motor shaft.
- NOTE: Measure distance from the fan blade to rear wall assembly before removal to aid in reassembly.
- F. Remove four screws from motor support assembly.
  - G. Remove motor mount clamp and remove motor from oven back.
  - H. Remove motor mount from motor.
  - I. Reassemble in reverse order and check system operation.

#### CAPACITOR – REPLACEMENT

- A. Shut off power at main breaker.
- B. Remove rear control box cover.
- C. Discharge capacitor.
- D. Remove capacitor.
- E. Reassemble in reverse order and check system operation.

#### ON/OFF SWITCH – REPLACEMENT

- A. Shut off power at main breaker.
  - B. Remove conveyor and front control box cover.
  - C. Depress spring clips on sides of switch and push out.
  - D. Remove wires from switch and mark for reassembly.
  - E. Reassemble in reverse order and check system operation.
- NOTE: Make sure switch housing is fully seated in control box housing.

#### FUSE HOLDER – REPLACEMENT

- A. Shut off power at main breaker.
- B. Remove rear control box cover.
- C. Remove wires from fuse holder and mark for reassembly.
- D. Remove mounting screws or mounting nut on fuse holder and remove fuse holder.
- E. Reassemble in reverse order and check system operation.

#### COOLING FAN, CONTROL BOX – REPLACEMENT

- A. Shut off power at main breaker.
- B. Remove appropriate control box cover and conveyor if necessary.
- C. Remove four mounting screws from fan frame.
- D. Disconnect power cord and remove fan.
- E. Reassemble in reverse order and check system operation. Check for air flow.

#### THERMOSTAT, COOLING FAN, REPLACEMENT

- A. Shut off power at main breaker.
- B. Remove conveyor and front control box cover.
- C. Remove wires and mark for reassembly.
- D. Remove two mounting screws and remove thermostat.
- E. Reassemble in reverse order and check system operation.

#### BURNER BLOWER MOTOR – REPLACEMENT

- A. Shut off power at main breaker.
- B. Remove rear control box cover.
- C. Unplug motor connector.
- D. Remove three mounting screws from blower tube at burner housing.
- E. Remove air shutter assembly from old motor for assembly on new motor.
- F. Reassemble in reverse order and check system operation.

NOTE: Check air shutter at approximately ½ open and adjust to get a blue flame with an occasional tip of yellow under high flame. A view port in the burner assembly should be used to observe flame.

#### HI-LIMIT THERMOSTAT, OVEN CAVITY – REPLACEMENT

- A. Shut off power at main breaker.
- B. Remove conveyor and bottom finger assembly. Remove rear control box cover.
- C. Remove capillary bulb from bracket in oven chamber and pull capillary tube through tube into control box.
- D. Remove all wires and mark for reassembly.
- E. Remove mounting nut and remove thermostat.



- F. Reassemble in reverse order and check system operation. Be sure capillary tube is securely in the mount.

NOTE: Push reset button on new thermostat.

#### TRANSFORMER, BURNER – REPLACEMENT

- A. Shut off power at main breaker.
- B. Remove conveyor and front control box cover.
- C. Remove all wires from transformer and mark for reassembly.
- D. Remove two mounting screws from transformer base and remove transformer.
- E. Reassemble in reverse order and check system operation.

#### OVEN CONTROL – REPLACEMENT

- A. Shut off power at main breaker.
- B. Remove conveyor and front control box cover.
- C. Remove all wiring connections and mark for reassembly.
- D. Remove oven control by pulling control from the mounting pins. Remove control from oven.
- E. Before installing new oven control, set voltage jumper (located at the bottom center of the oven control) to the proper voltage (120V/240V) position. Set frequency jumper to the proper frequency (50Hz/60Hz). Install the four pushbutton extensions (included with the oven control) by pushing the extensions onto the four set buttons on control.
- F. Reassemble in reverse order and check system operation.
- G. Set the oven control for the proper operating mode. The 1100 series ovens use a single temperature control system. The oven control must be set to the proper operating mode. Set the control as follows: With the oven power switch “off”, depress the “time” and “up” buttons and turn the oven “on”. Control will indicate “Imp I or Imp II” Release the buttons, The control will indicate “Temp to store”. Press the “up” or “down” button until “Imp II” appears on the display. Press the “temp” button. The control is now set for single burner operation.

#### TRANSFORMER – CONTROL – REPLACEMENT

*See “TRANSFORMER –BURNER - REPLACEMENT*

#### THERMOCOUPLE – REPLACEMENT

- A. Shut off power at main breaker.
- B. Remove conveyor and bottom finger assembly.
- C. Remove front control box cover.
- D. Remove thermocouple from bracket in oven chamber and pull thermocouple through tube into control box.
- E. Remove two thermocouple wires from temperature control. Note wire color and location for reassembly
- F. Reassemble in reverse order and check system operation

#### THERMOCOUPLE MEASUREMENT

TEMPERATURE (°F)	D.C. MILLIVOLTS
200°	2.8
250°	4.0
300°	5.1
350°	6.0
400°	7.1
450°	8.2
500°	9.3
550°	10.4
600°	11.5

## BURNER CONTROL – REPLACEMENT

- A. Shut off power at main breaker.
- B. Remove conveyor and front control box cover.
- C. Remove wires from control and mark for reassembly.
- D. Remove mounting screws from control and remove burner control.
- E. Reassemble in reverse order and check system operation.

## GAS VALVE – REPLACEMENT

- A. Shut off power at main breaker.
- B. Shut off gas supply to the oven and disconnect the flexible gas line to oven.
- C. Remove rear control box cover.
- D. Remove the manual gas shut-off valve.
- E. Remove screws from the bulkhead plate on inlet gas pipe and remove inlet gas pipe.
- F. Remove pilot tube and wiring from gas valve, Mark all wiring for reassembly.
- G. Disconnect pipe union in gas line and remove gas valve and piping assembly.
- H. Remove piping from gas valve.
- I. Reassemble in reverse order and check system operation.
- J. Check all gas line fitting for leaks.
- K. Adjust the gas manifold pressure on the gas valve. Refer to the specification plate on the oven for proper rating.

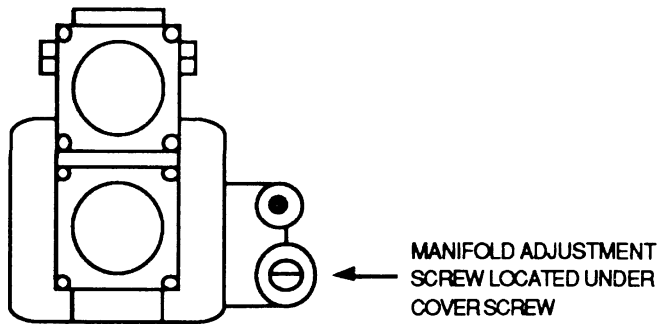

## TEMPERATURE REGULATION VALVE – REPLACEMENT

- A. Shut off power at main breaker.
- B. Shut off gas supply to the oven and disconnect the flexible gas line to oven.
- C. Remove rear control box cover.
- D. Remove bypass tube from burner manifold.
- E. Remove wiring from valve and mark for reassembly.
- F. Remove four mounting nuts from burner manifold and disconnect pipe union.
- G. Remove temperature regulation valve and piping from oven.

## HOT SURFACE IGNITER – REPLACEMENT

- A. Shut off power at main breaker.
- B. Shut off gas supply to the oven and disconnect the flexible gas line to oven.
- C. Remove conveyor and control box covers.
- D. Remove temperature regulation valve. See "TEMPERATURE REGULATION VALVE".
- E. Disconnect wires from burner control.
- F. Remove three mounting screws and remove burner venturi.
- G. Remove mounting nut and remove hot surface igniter assembly.
- H. Reassemble in reverse order and check system operation.
- I. Check all gas line fittings for leaks.

#### BYPASS ORIFICE – REPLACEMENT

- A. Shut off power at main breaker.
- B. Shut off gas supply to the oven and disconnect the flexible gas line to oven.
- C. Remove rear control box cover.
- D. Disconnect bypass tube from gas valve.
- E. Remove bypass orifice from gas valve.
- F. Reassemble in reverse order and check system operation.
- G. Check all gas line fittings for leaks.

#### MAIN BURNER ORIFICE – REPLACEMENT

- A. Shut off power at main breaker.
- B. Shut off gas supply to the oven and disconnect the flexible gas line to oven.
- C. Remove rear control box cover.
- D. Remove burner manifold. See “TEMPERATURE REGULATION VALVE”.
- E. Remove main burner orifice from burner manifold.
- F. Reassemble in reverse order and check system operation.
- G. Check all gas line fittings for leaks.

#### REVERSING SWITCH – REPLACEMENT

- A. Shut off power at main breaker.
- B. Remove rear control box cover.
- C. Remove wires from reversing switch and mark for reassembly.
- D. Remove mounting nut and remove switch.
- E. Reassemble in reverse order and check system operation.

#### CONVEYOR DRIVE MOTOR – REPLACEMENT

- A. Shut off power at main breaker.
- B. Remove conveyor and both control box covers.
- C. Disconnect all wiring from motor and mark for reassembly.
- D. Remove coupling from motor drive shaft.
- E. Remove four screws and remove conveyor motor and mounting bracket.
- F. Remove mounting bracket from conveyor motor.
- G. Reassemble in reverse order and check system operation.

#### REVERSING CONVEYOR DIRECTION

- A. Shut off power at oven switch.
- B. Set conveyor reversing switch in the other position.
- C. Turn oven “on” and check for proper operation.

#### CAPACITOR, CONVEYOR DRIVE MOTOR – REPLACEMENT

- A. Shut off power at main breaker.
- B. Remove rear control box cover.
- C. Discharge capacitor before removing wires. Mark wires for reassembly.
- D. Remove mounting screw and remove capacitor.
- E. Reassemble in reverse order and check system operation.

#### AIR PRESSURE SWITCH – REPLACEMENT

- A. Shut off power at main breaker.
- B. Remove conveyor and front control box cover.
- C. Disconnect wiring from air pressure switch and mark for reassembly.
- D. Disconnect air tube from air pressure switch.
- E. Remove two mounting screws and remove air pressure switch.
- F. Reassemble in reverse order and check system operation. Be sure to calibrate new air pressure switch. For proper calibration, see below.

- G. Turn adjusting screw on air pressure switch fully counter clockwise.
- H. Turn oven "on".
- I. Turn adjusting screw on air pressure switch clockwise until heat shuts off.
- J. Turn adjusting screw on air pressure switch counter clockwise ¼ turn.
- K. Reassemble control panel top and front cover.

#### BEARING, CONVEYOR – REPLACEMENT

- A. Remove conveyor from oven and place on a flat work surface.
- B. Remove connecting links from conveyor belt. See Installation Operations manual for proper procedure. Remove conveyor belt from conveyor.
- C. Move drive shaft or idler shaft toward end of conveyor, and shaft with bearing will now slip out of conveyor frame.
- D. Remove bearing from conveyor shaft.
- E. Reassemble in reverse order and check system operation.

#### MERCURY CONTACTOR – REPLACEMENT

- A. Shut off power at main breaker.
- B. Remove rear control box cover.
- C. Disconnect all wires and mark for reassembly.
- D. Remove screws from mounting bracket and remove contactor.
- E. Reassemble in reverse order and check system operation.

#### HEATING ELEMENT – REPLACEMENT

- A. Shut off power at main breaker.
- B. Remove back cover.
- C. Disconnect heating element wires and mark for reassembly.
- D. Disconnect motor wiring and mark for reassembly.
- E. Remove oven back from oven.
- F. Remove fan shroud.
- G. Heating element may now be unbolted and removed.
- H. Check new heating element for proper voltage. Reassemble in reverse order and check for proper operation.

This page intentionally left blank.

## GENERAL VIEW

Old Model Number	→	New Model Number
1116-080-A (or A1)	→	1116-00z-U-Kxxxx
1116-062-8R	→	1116-00z-U-Kxxxx
1116-023-8	→	1116-00z-U-Kxxxx
1117-080-A (or A1)	→	1117-00z-U-Kxxxx
1117-023-8	→	1117-00z-U-Kxxxx
1130-080-A (or A1)	→	1130-00z-U-Kxxxx
1130-08H-A	→	N/A
1131-080-A (or A1)	→	1131-00z-U-Kxxxx
1131-08H-A	→	N/A
1132-080-A (or A1)	→	1132-00z-U-Kxxxx
1132-08H-A	→	1172-00z-U-Kxxxx
1132-002-8	→	1174-00z-U-Kxxxx
1132-023-8	→	1132-00z-U-Kxxxx
1133-080-A (or A1)	→	1133-00z-U-Kxxxx
1133-08H-A	→	1173-00z-U-Kxxxx
1161-080-A	→	1131-00z-U-Kxxxx
1162-080-A	→	1132-00z-U-Kxxxx
N/A	→	1178-00z-U-Kxxxx

LETTER	PART NUMBER	DESCRIPTION
A*	370412	Cross support
B*	370416	Stand side
C*	369231	Caster, 4" w/threaded stem
D*	369232	Adjustable leg
E	369390	Caster, 4" w/mounting plate
F		Oven Door, See "Conveyor / Door View" Section
G	370010	Bottom finger housing
H	369502	Bottom finger cover
I	369504	Top finger housing (model ending with -080-A)
	370487	Top finger housing (model ending with -080-A1)
J	369503	Top finger cover (model ending with -080-A)
	370486	Top finger cover (model ending with -080-A1)
K	370415	Oven top
L	369659	Conveyor hole cover (S/N 2052462 & below)
	370679	Conveyor hole cover (S/N 2052463 & above)
M	371066	Baffle
N	369211	Thumb screw
O		Columnating plate, see Installation & Operations manual
P		Columnating plate, see Installation & Operations manual

*\* A new stand was designed and implemented on March 16, 2009. Parts are not compatible between old and new stand styles. See Addendum A in the back of this manual for a parts breakdown and assembly instructions.*

# GENERAL VIEW

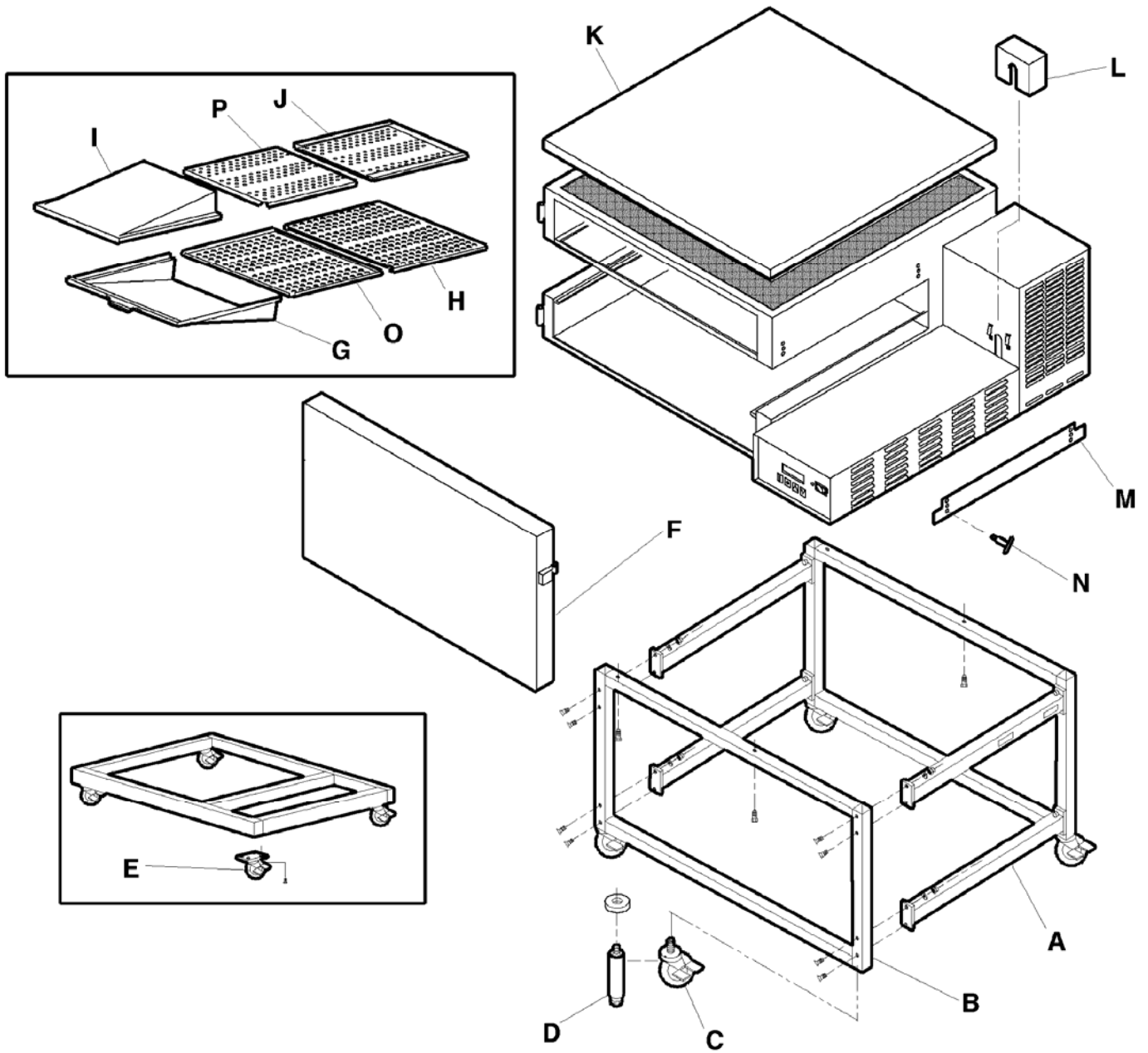

## CONTROL BOX, FRONT

Old Model Number	→	New Model Number
1116-080-A (or A1)	→	1116-00z-U-Kxxxx
1116-062-8R	→	1116-00z-U-Kxxxx
1116-023-8	→	1116-00z-U-Kxxxx
1117-080-A (or A1)	→	1117-00z-U-Kxxxx
1117-023-8	→	1117-00z-U-Kxxxx

LETTER	PART NUMBER	DESCRIPTION
A	369805	Switch, on/off
B	370408	Facia, pushbutton
C	370417	Control board
	370409	Display only
D	369531	Transformer, 24VAC
E	369507	Thermostat, cooling fan
F	369124	Cooling fan
G	369532	Ignition control
H	370410	Stand off Plate (SN 0903210000317 & Below)**
	369856	Stand off Support (SN 0903210000318 & Above)**
I	369680	Front cover assy.

\*\* This pertains to all non-TU units.



## CONTROL BOX, FRONT VIEW

Old Model Number	→	New Model Number
1116-080-A (or A1)	→	1116-00z-U-Kxxx
1116-062-8R	→	1116-00z-U-Kxxx
1116-023-8	→	1116-00z-U-Kxxx
1117-080-A (or A1)	→	1117-00z-U-Kxxx
1117-023-8	→	1117-00z-U-Kxxx

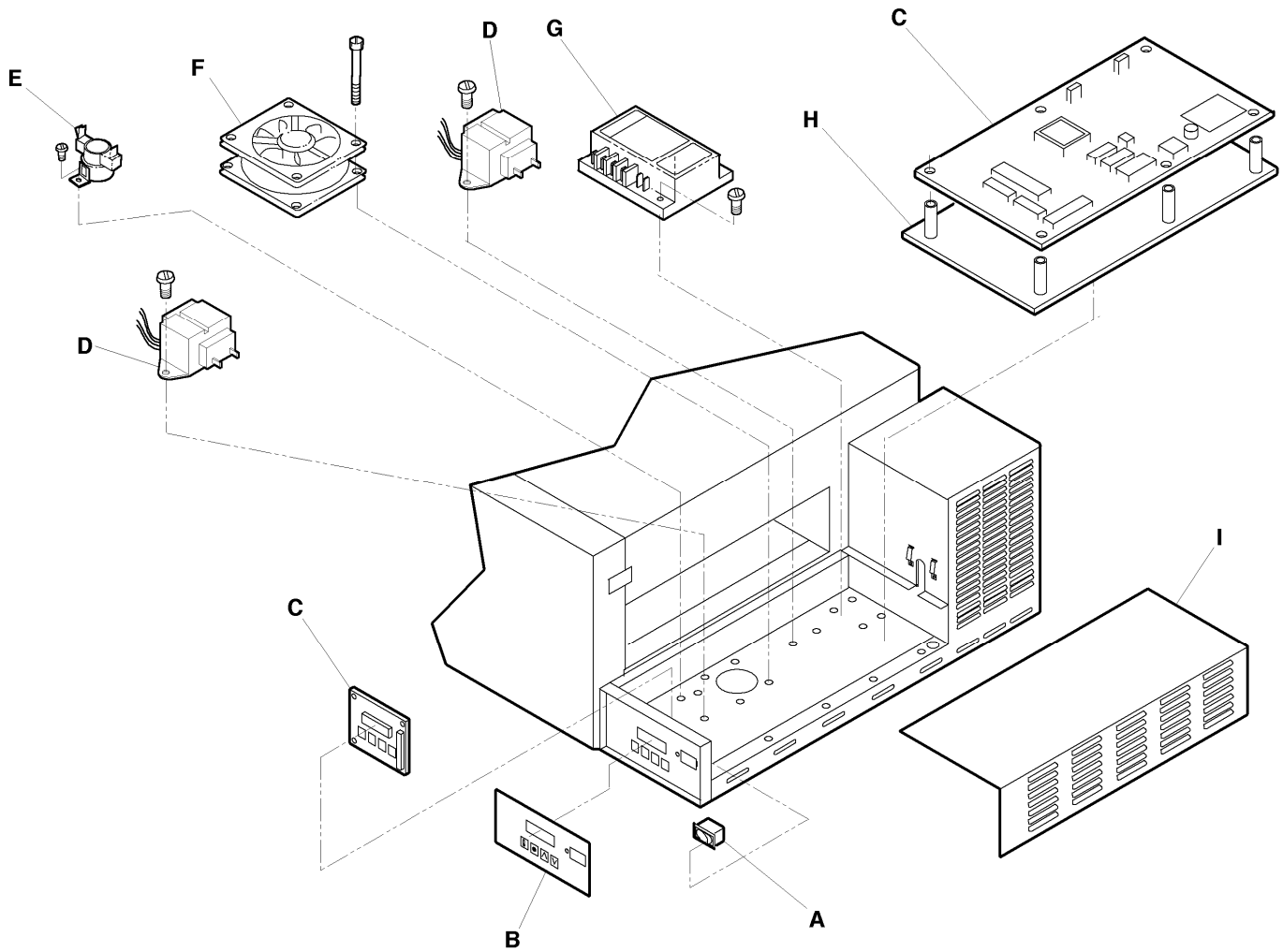

## CONTROL BOX, FRONT

Old Model Number		New Model Number
1130-080-A (or A1)	→	1130-00z-U-Kxxxx
1130-08H-A	→	N/A
1131-080-A (or A1)	→	1131-00z-U-Kxxxx
1131-08H-A	→	N/A
1132-080-A (or A1)	→	1132-00z-U-Kxxxx
1132-08H-A	→	1172-00z-U-Kxxxx
1132-002-8	→	1174-00z-U-Kxxxx
1132-023-8	→	1132-00z-U-Kxxxx
1133-080-A (or A1)	→	1133-00z-U-Kxxxx
1133-08H-A	→	1173-00z-U-Kxxxx
1161-080-A	→	1131-00z-U-Kxxxx
1162-080-A	→	1132-00z-U-Kxxxx
N/A	→	1178-00z-U-Kxxxx

LETTER	PART NUMBER	DESCRIPTION
A	369680	Front cover assy.
B	369508	Timer, 20-minute (S/N 0809210000016 & below)
	370466	Timer, 20-minute (S/N 0809210000017 & above)
C	369432	On/off switch
D	370408	Facia, push button
E	370417	Control Board
	370409	Display only
F	369427	Transformer, control
G	369507	Thermostat, cooling fan
H	369124	Cooling Fan (S/N 0809210000016 & below)
	369378	Cooling Fan (S/N 0809210000017 & above)
I	369523	Relay, Oven Start (S/N 0809210000016 & below)
	369422	Relay, Oven Start (S/N 0809210000017 & above)
J	369025	Air pressure switch, Johnson
	370673	Air Pressure Switch, Gold Tech
K	370410	Stand-off Plate Assy (SN 0903210000317 & Below)**
	369856	Stand off Support (SN 0903210000318 & Above)**

\*\* This pertains to all non-TU units.

## CONTROL BOX, FRONT VIEW

Old Model Number		New Model Number
1130-080-A (or A1)	→	1130-00z-U-Kxxxx
1130-08H-A	→	N/A
1131-080-A (or A1)	→	1131-00z-U-Kxxxx
1131-08H-A	→	N/A
1132-080-A (or A1)	→	1132-00z-U-Kxxxx
1132-08H-A	→	1172-00z-U-Kxxxx
1132-002-8	→	1174-00z-U-Kxxxx
1132-023-8	→	1132-00z-U-Kxxxx
1133-080-A (or A1)	→	1133-00z-U-Kxxxx
1133-08H-A	→	1173-00z-U-Kxxxx
1161-080-A	→	1131-00z-U-Kxxxx
1162-080-A	→	1132-00z-U-Kxxxx
N/A	→	1178-00z-U-Kxxxx

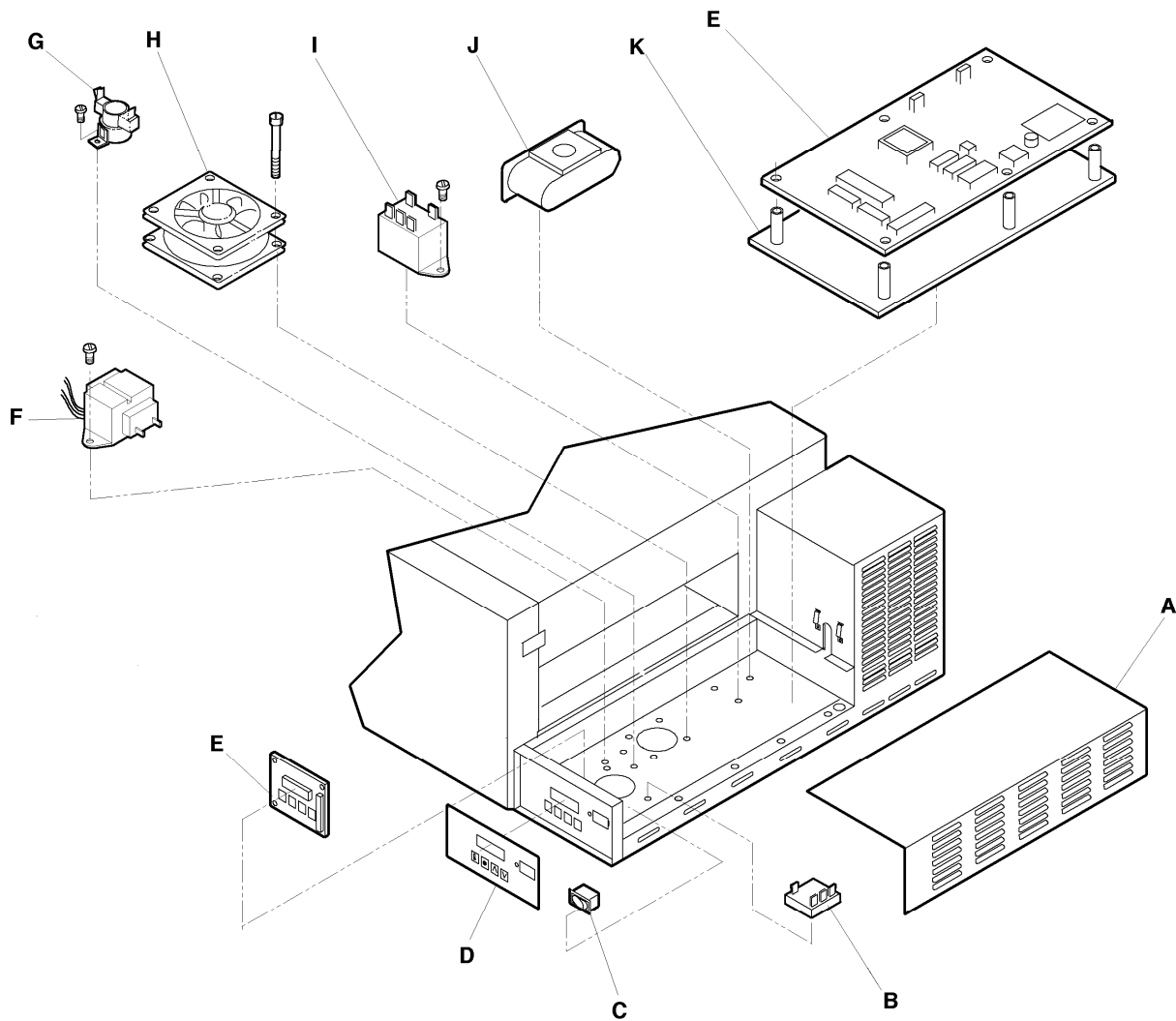

## CONTROL BOX, REAR

Old Model Number	→	New Model Number
1116-080-A (or A1)	→	1116-00z-U-Kxxxx
1116-062-8R	→	1116-00z-U-Kxxxx
1116-023-8	→	1116-00z-U-Kxxxx
1117-080-A (or A1)	→	1117-00z-U-Kxxxx
1117-023-8	→	1117-00z-U-Kxxxx

LETTER	PART NUMBER	DESCRIPTION
A	369192	Capacitor
B	370378	Conveyor motor assy. (S/N 2052462 & below)
	370675	Conveyor motor assy. (S/N 2052463 & above)
C	369901	Burner manifold
D	369568	Burner venturi, Nat. gas
	369938	Burner venturi, L.P. gas
E	369566	Orifice, main, Nat. gas
	369524	Orifice, main, L.P. gas
F	369552	Hot surface igniter
G	369398	Valve, temperature regulation
H	370359	Reversing switch, conveyor
I	369366	Burner blower motor
J	369401	Air shutter assy.
K	369556	Orifice, bypass, Nat. gas
	369557	Orifice, bypass, L.P. gas
L	369263	Gas valve, Nat./L.P.
M	357067	Thermostat, oven cavity hi-limit
N	370376	Capacitor, conveyor motor (S/N 2052462 & below)
	370681	Capacitor, conveyor motor (S/N 2052463 & above)
O	369129	Fuse holder
P	370362	Thermocouple, type "K"
Q	369682	Control box cover, rear
R	369166	Fuse, 10A.
S	369331	Finger guard
T	369124	Cooling Fan
U	370364	Ground lug
V	369537	Power cord

## CONTROL BOX, REAR VIEW

Old Model Number	→	New Model Number
1116-080-A (or A1)	→	1116-00z-U-Kxxxx
1116-062-8R	→	1116-00z-U-Kxxxx
1116-023-8	→	1116-00z-U-Kxxxx
1117-080-A (or A1)	→	1117-00z-U-Kxxxx
1117-023-8	→	1117-00z-U-Kxxxx

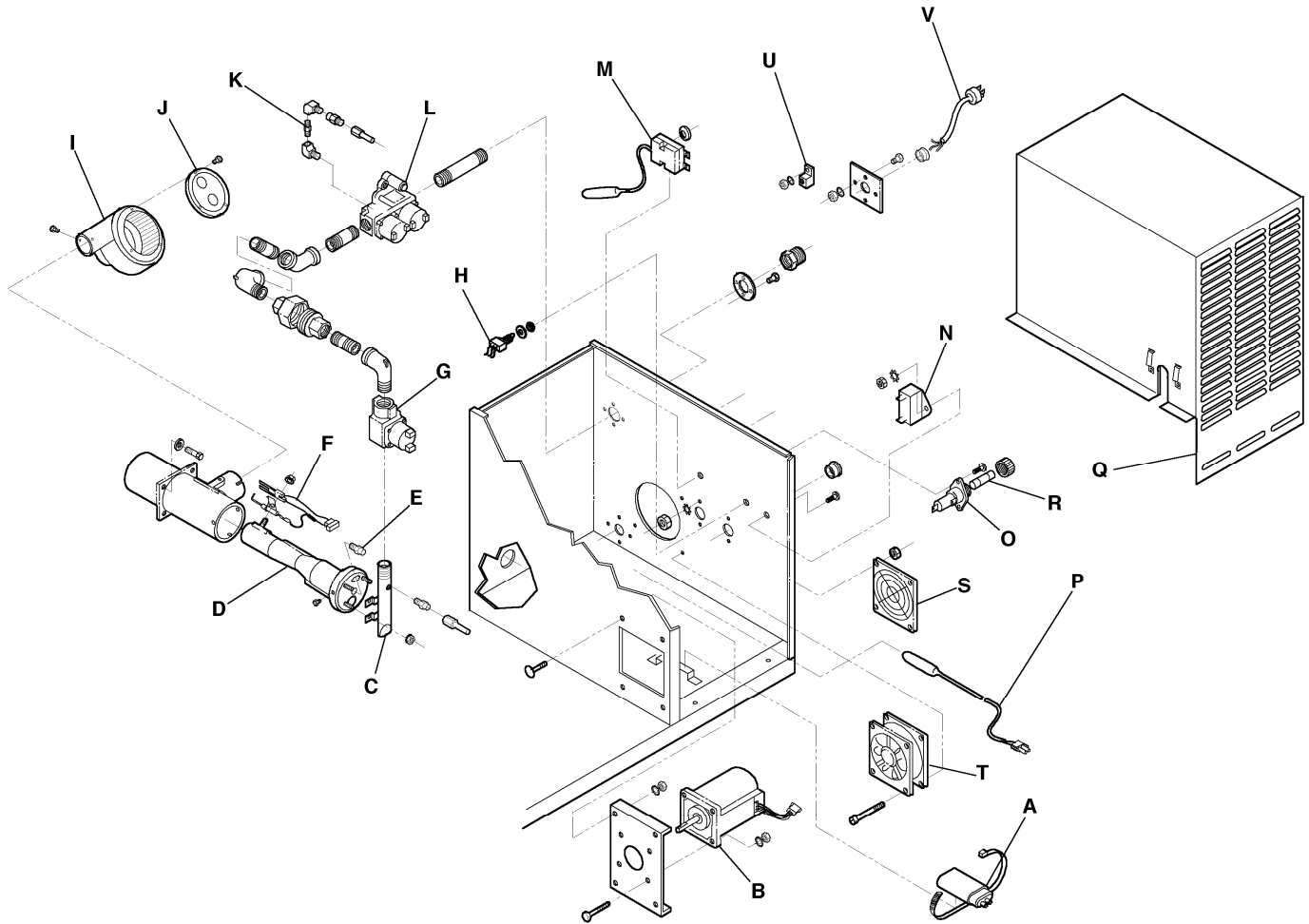

## CONTROL BOX REAR

Old Model Number		New Model Number
1130-080-A (or A1)	→	1130-00z-U-Kxxxx
1130-08H-A	→	N/A
1131-080-A (or A1)	→	1131-00z-U-Kxxxx
1131-08H-A	→	N/A
1132-080-A (or A1)	→	1132-00z-U-Kxxxx
1132-08H-A	→	1172-00z-U-Kxxxx
1132-002-8	→	1174-00z-U-Kxxxx
1132-023-8	→	1132-00z-U-Kxxxx
1133-080-A (or A1)	→	1133-00z-U-Kxxxx
1133-08H-A	→	1173-00z-U-Kxxxx
1161-080-A	→	1131-00z-U-Kxxxx
1162-080-A	→	1132-00z-U-Kxxxx
N/A	→	1178-00z-U-Kxxxx

LETTER	PART NUMBER	DESCRIPTION
A	369192	Capacitor
B	369200	Relay, Main Fan (S/N 0809210000016 & below)
	369422	Relay, Main Fan (S/N 0809210000017 & above)
C	369124	Cooling Fan
	369378	Cooling Fan (S/N 0809210000017 & above)
D	370362	Thermocouple, Type "K"
E	369185	Terminal block section 1 Phase (2 required)
	369187	Terminal block section (3 required)
	369186	Terminal block end 1 Phase
	369188	Terminal block end 3 Phase
F	370067	Mercury contactor 2 pole (1 Phase)
	369479	Mercury contactor 3 pole (3 Phase)
	370485	Mercury contactor 3 pole (3 Phase) – "08H-A" model only
G	369682	Control box cover, rear
H	357067	Thermostat, oven cavity hi-limit
I	370359	Reversing switch, conveyor
J	370302	Receptacle
K	369129	Fuse holder
L	370383	Capacitor, conveyor motor (S/N 2052462 & below)
	370382	Capacitor, conveyor motor (S/N 2052463 & above)
M	370384	Conveyor motor (S/N 2052462 & below)
	370676	Conveyor motor (S/N 2052463 & above)
N	369331	Finger guard
O	369166	Fuse, 10A.
P	370364	Ground lug
Q	370134	Electrical Box Cover
R	370133	Electrical Box

## CONTROL BOX, REAR VIEW

Old Model Number		New Model Number
1130-080-A (or A1)	→	1130-00z-U-Kxxxx
1130-08H-A	→	N/A
1131-080-A (or A1)	→	1131-00z-U-Kxxxx
1131-08H-A	→	N/A
1132-080-A (or A1)	→	1132-00z-U-Kxxxx
1132-08H-A	→	1172-00z-U-Kxxxx
1132-002-8	→	1174-00z-U-Kxxxx
1132-023-8	→	1132-00z-U-Kxxxx
1133-080-A (or A1)	→	1133-00z-U-Kxxxx
1133-08H-A	→	1173-00z-U-Kxxxx
1161-080-A	→	1131-00z-U-Kxxxx
1162-080-A	→	1132-00z-U-Kxxxx
N/A	→	1178-00z-U-Kxxxx

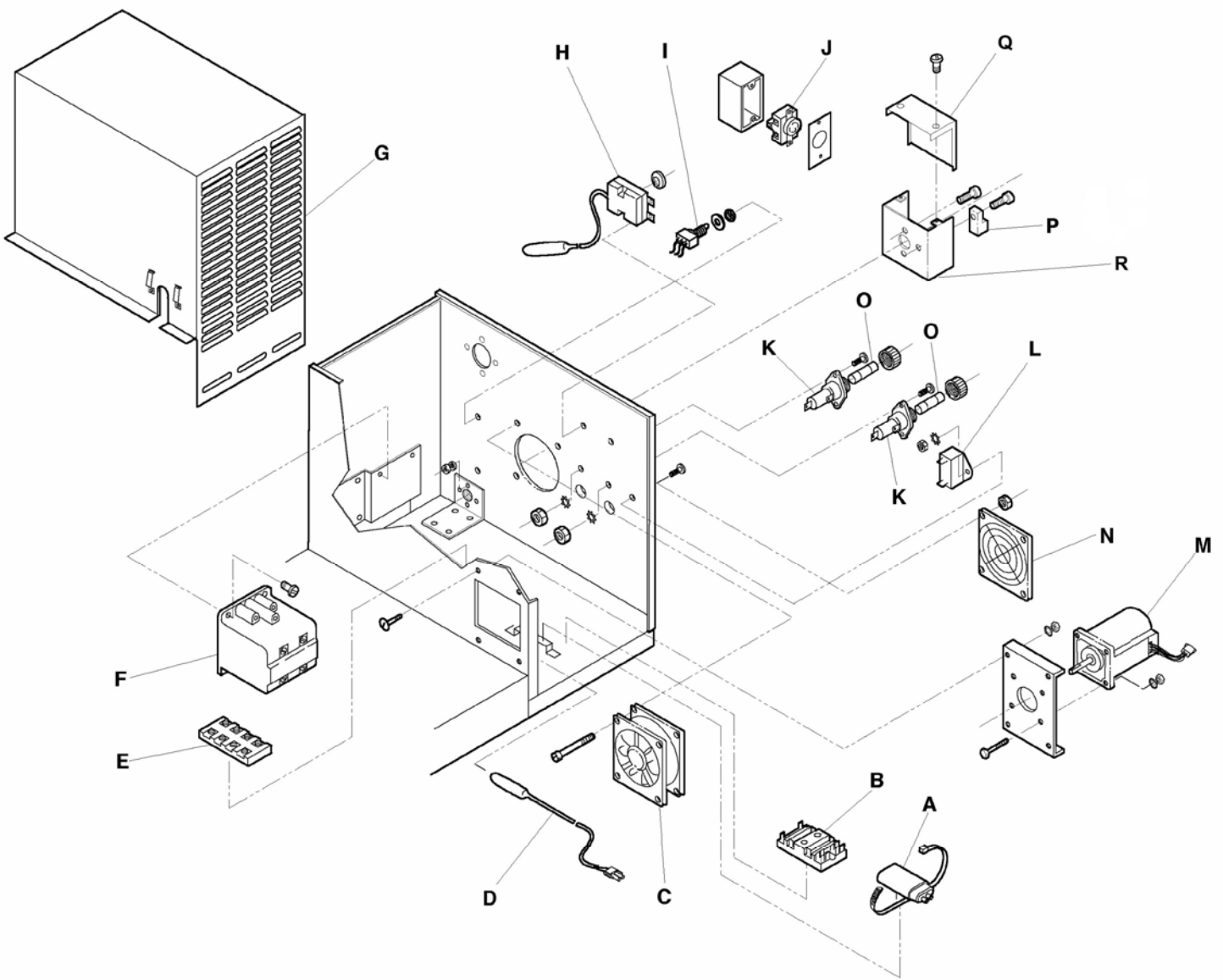

## OVEN BACK ASSEMBLY ALL MODELS

LETTER	PART NUMBER	DESCRIPTION
A	369182	Fan
B	369899	Fan shroud
C	369655	Stand off
D	Heating Elements	
	369183	208 Volt
	369184	240 Volt
	370648	208 Volt – Models 1130-08H-A & 1132-08H-A (S/N 10062053640 & below)
	370645	240 Volt – Models 1131-08H-A & 1133-08H-A (S/N 10062053640 & below)
	370690	208 Volt – Models 1130-08H-A & 1132-08H-A (S/N 10062053641 & above)
	370689	240 Volt – Models 1131-08H-A & 1133-08H-A (S/N 10062053641 & above)
E	369976	Rear wall – Gas Ovens
	369549	Rear wall – Electric Ovens
		Rear wall for the following models: 1132-08H-A 1172-000-U 1130-08H-A 1170-000-U
	369581	Motor mount
G		Motor
	369539	Gas ovens (120VAC)
	369181	Electric ovens (208/240VAC)
H	369695	Bracket, motor
I	369033	Clamp, motor
J	369681	Cover, back
K	369979	Bracket, hi-limit
L	369227	Spring
M	369541	Bracket, thermocouple



# OVEN BACK ASSEMBLY VIEW ALL MODELS

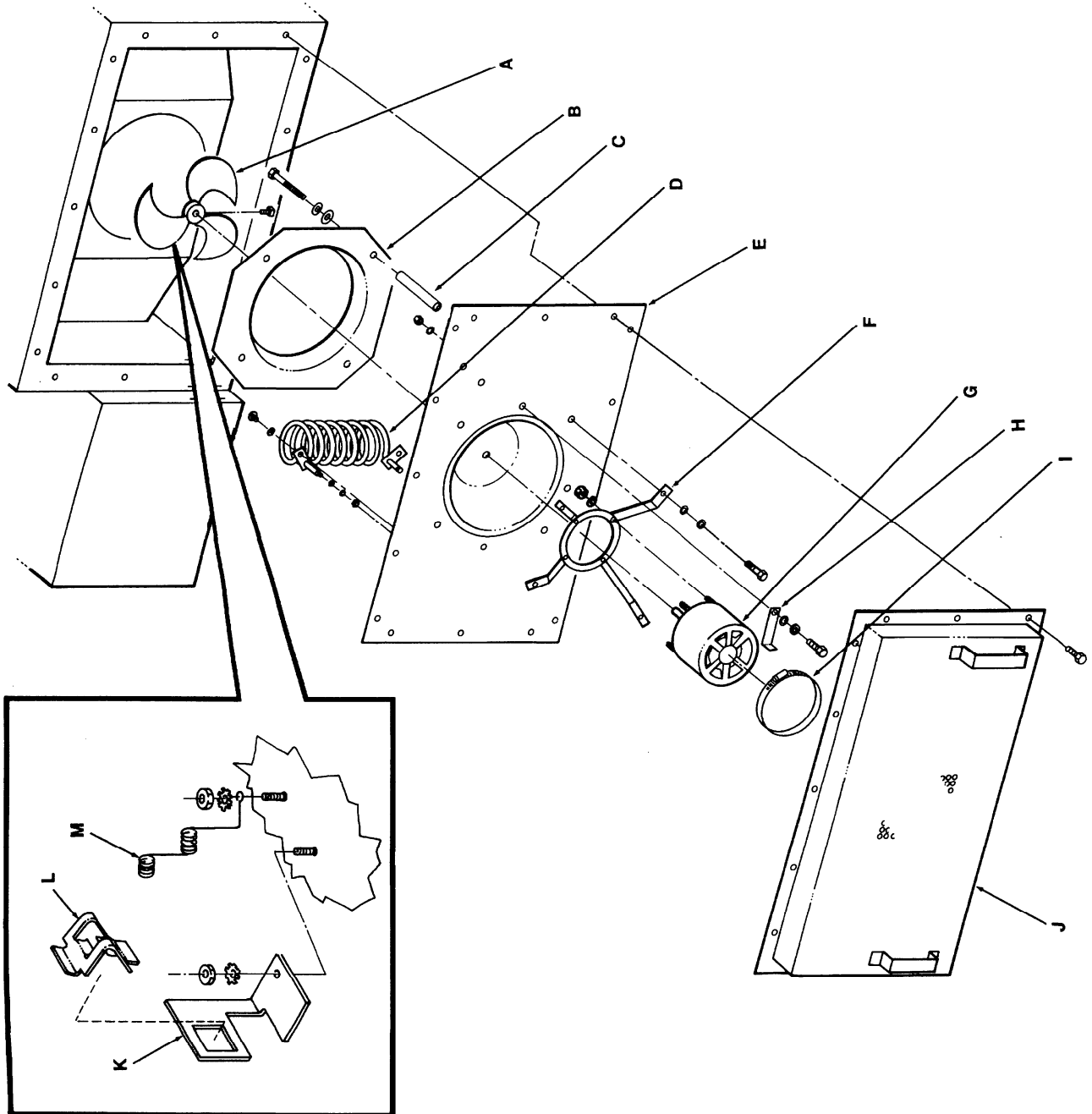

## CONVEYOR / DOOR ALL MODELS

LETTER	PART NUMBER	DESCRIPTION
A	369190	Coupler (S/N 2052462 & below)
	370671	Coupler (S/N 2052463 & above)
B	369512	Coupling center (S/N 2052462 & below)
C	369269	Ball plunger (S/N 2052462 & below)
D	370116	Set screw (S/N 2052462 & below)
E	369223	Crumb pan, right (S/N 2045452 & below)
		Crumb pan, right and left (S/N 2045453 & above)
F	369224	Crumb pan, left (S/N 2045452 & below)
G	369666	Conveyor frame assembly
H	369226	Pan stop
J	369516	Conveyor bearing
K	369514	Idler shaft
L	369515	Sprocket (includes set screw), Regular Conveyor
	369978	Set screw
	370509	Sprocket (includes set screw), Heavy-Duty Conveyor
M	369238	Drive shaft (S/N 2052462 & below)
	370678	Drive shaft (S/N 2052463 & above)
N	369513	Hinge
O	370413	Door assembly
P	370016	Impinger nameplate
Q	369501	Door latch & catch
R	370414	Door assembly with window
S	369927	Window frame, top (NLA – See Access Door Section)
T	369925	Glass, access window (NLA – See Access Door Section)
U	369926	Window frame, bottom (NLA – See Access Door Section)
W	369929	Retainer, window (See Access Door Section)
X	369165	Splice clip, conveyor belt
Y	369194	Conveyor belt (complete), Regular Conveyor
	369394	Conveyor belt (1-Foot section), Regular Conveyor
	370155	Conveyor Belt (complete), Heavy-Duty Conveyor
	370157	Conveyor Belt (1-Foot Section), Heavy-Duty Conveyor
Not Shown	369471	Roll Pin
***	369222	Complete Conveyor Assy (S/N 2052462 & below)
***	370677	Complete Conveyor Assy (S/N 2052463 & above)

\*\*\* Complete Conveyor Assembly includes letters A, G, J, K, L, M, X, and Y.

# CONVEYOR / DOOR VIEW ALL MODELS

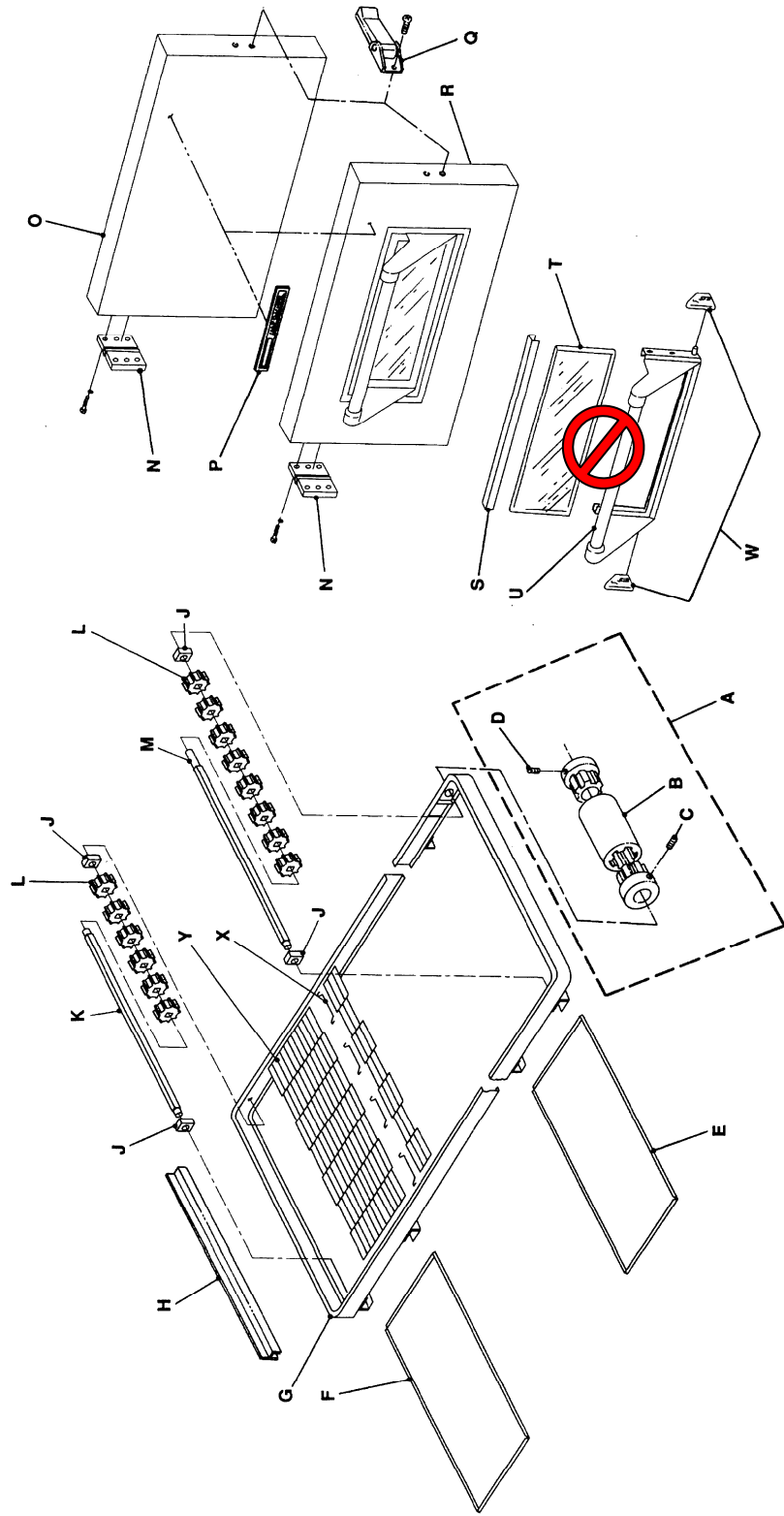

**ACCESS DOOR  
ALL MODELS (SN 0908210000875 AND BELOW)**

LETTER	PART NUMBER	DESCRIPTION
	369110	Access Door Assembly
A	370724	Extrusion
B	369928	Dowel, Access Door
C	370726	Bracket Assembly
D	370725	Dowel Thread
E	370727	Bracket Assembly
F	370723	Glass
Not Shown	369929	Retainer, Window

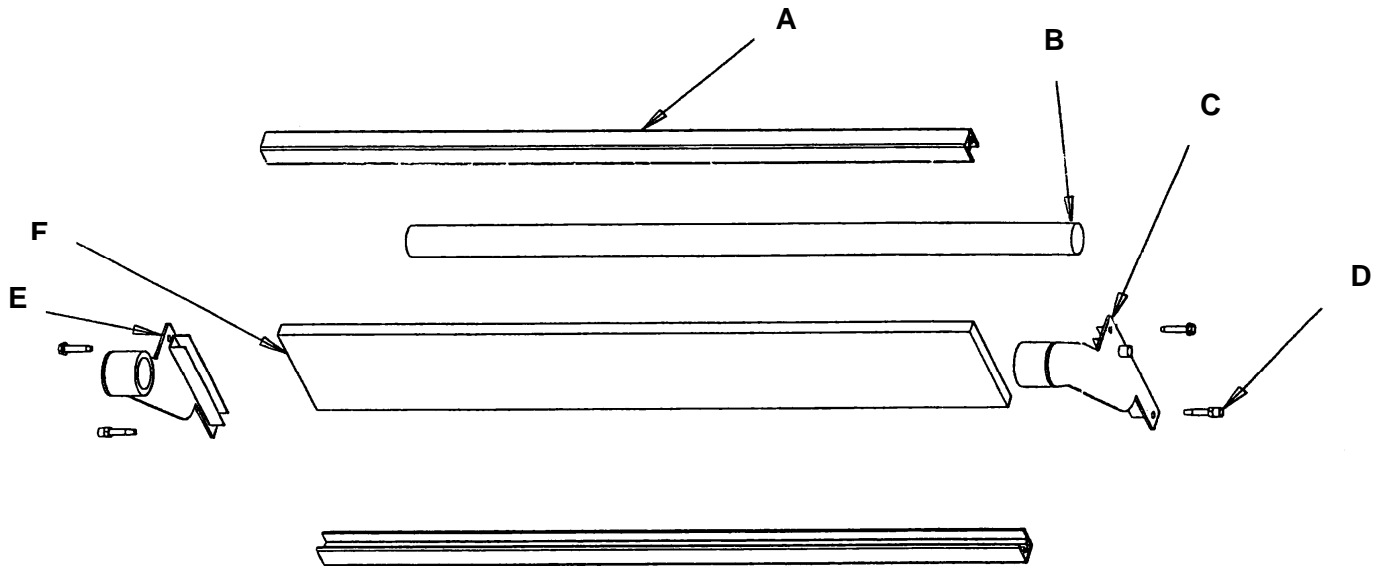

**STAINLESS STEEL ACCESS DOOR  
ALL MODELS (SN 0908210000875 AND ABOVE)**

LETTER	PART NUMBER	DESCRIPTION
	369110	Access Door Assembly
A	371140	Bracket Assembly, Left
B	371142	Dowel, Access Door
C	370722	Screw
D	371143	8-32 x 3/8 Hx Serr Flng
E	371141	Bracket Assembly, Right
F	370725	Dowel Thread
G	371144	Access Door Frame (top or bottom)
H	370723	Glass

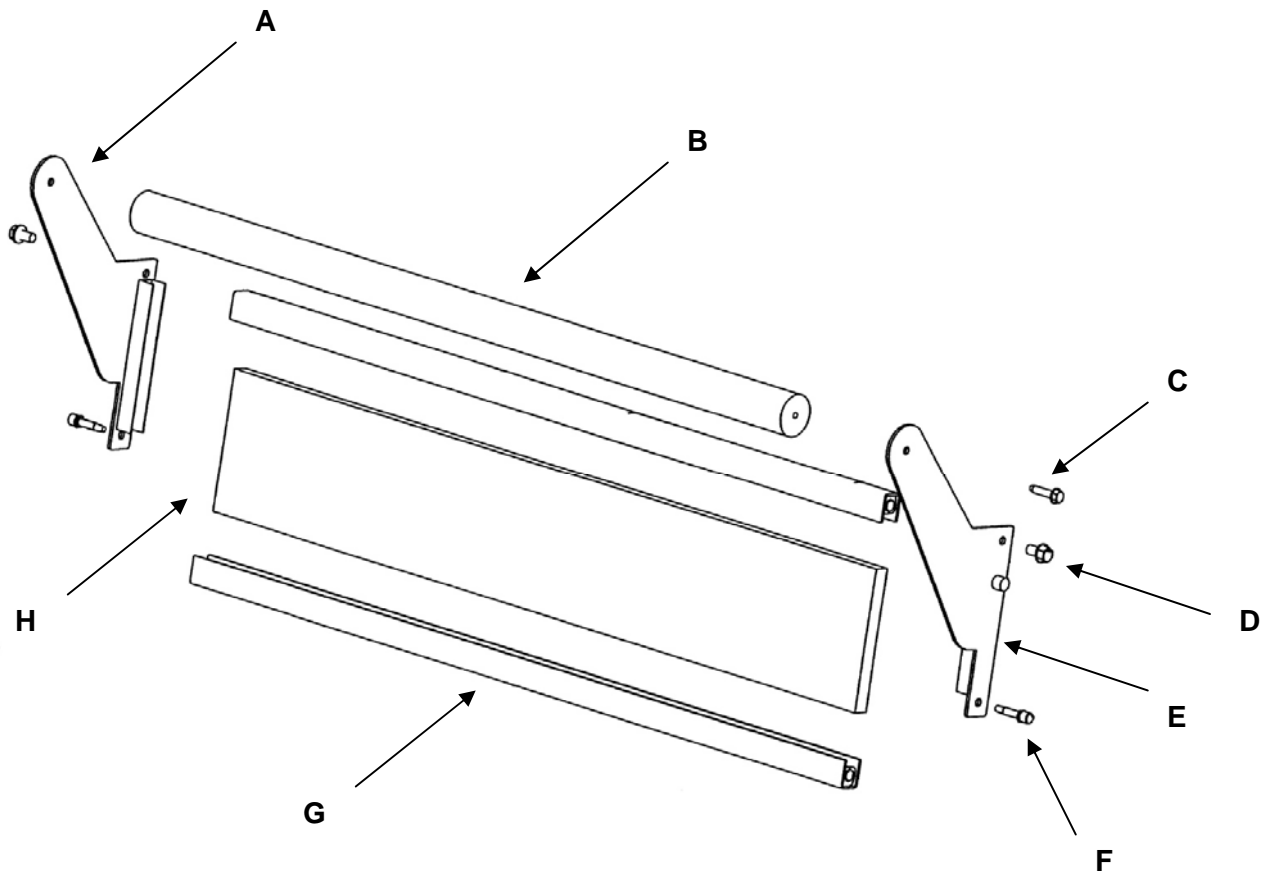

## ADDENDUM A NEW STYLE OVEN STAND (BEGINNING MARCH 16, 2009)

1. Insert the four Stand Side Bars (G) into the four holes located on each of the Front/Back Assemblies (A). Note: The Stand Side Bar that contains labels should be facing "out" so that the labels can be easily read by the operator.
2. Attach the Stand Side Bars to the Front/Back Assemblies and tighten using the 1 ¼" Hexagon Bolts (B), Washers (E) and Acorn Nuts (D) provided. Two sets each of the bolts, washers and nuts are to be used at each intersection of Stand Side Bars and Front Back Assemblies for a total of 16 sets.
3. Select Caster or Adjustable Leg and screw into nutsert in the bottom corner of each Front/Back Stand Assembly. Tighten Casters securely.
4. Set assembled Stand on casters/legs in an open, clear area and lock casters, as applicable, in preparation for mounting oven on stand.
5. When placing the oven on the stand, align the bolt holes located in the Front/Back Stand Assemblies with the holes located in the bottom of the oven. With holes in alignment, insert the 2 ½" Hexagon Bolts and tighten to secure the oven to Stand (Fig. 2).



**CAUTION:**

USE EXTREME CARE IN STEP #5 TO INSURE OVEN DOESN'T SLIP OFF STAND BEFORE BOLTS HAVE SECURED OVEN TO STAND.

HARDWARE PROVIDED FOR STAND ASSEMBLY		
LETTER	PART #	DESCRIPTION
A	90000799	Front / Back Stand Assemblies
B	000151SP	Hexagon Bolt (1 ¼")
C	369231	Caster, 4"
D	2133001	Acorn Nut
E	000821SP	Washer
F	369233	Hexagon Bolt (2 ½" )
G	10004656	Stand Side Bar
H		Adjustable Leg for 1127-1 stand
Not Shown	9002533	Shelf for 1127-1 stand
Not Shown		Hexagon Bolt (1/2") for double-stack oven configuration

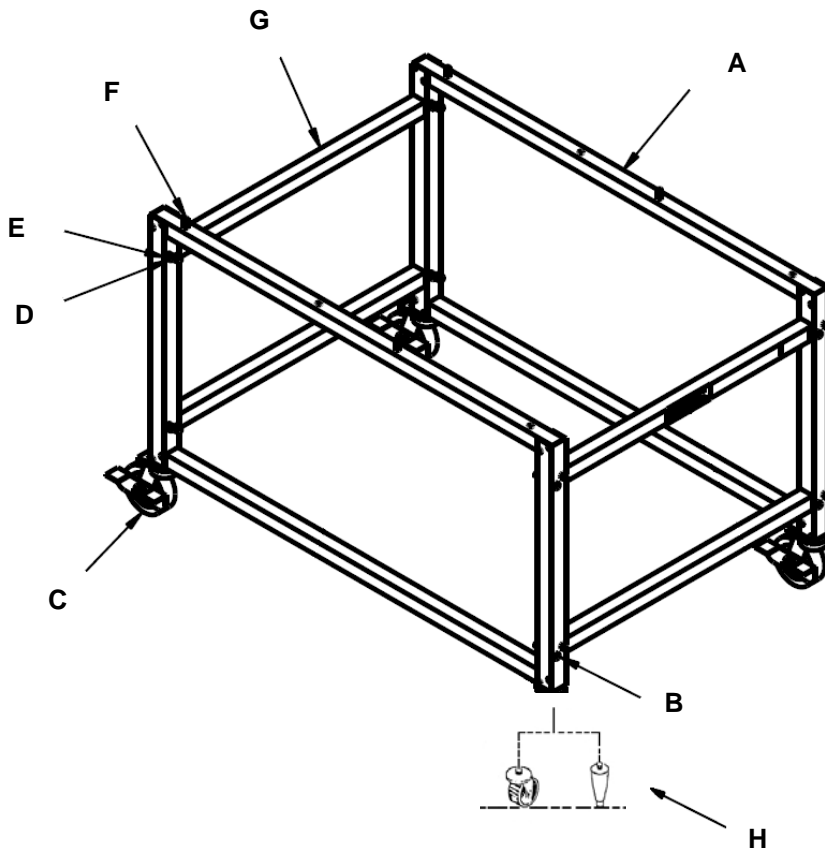

This page intentionally left blank.

