



CRESCENDO



ILLUSTRATED PARTS CATALOG

Designs, materials, weights, specifications, and dimensions for equipment or replacement parts are subject to change without notice.

BUNN-O-MATIC CORPORATION

POST OFFICE BOX 3227

SPRINGFIELD, ILLINOIS 62708-3227

PHONE: (217) 529-6601 FAX: (217) 529-6644

To ensure you have the latest revision of the Operating Manual, Illustrated Parts Catalog, Programming Manual, or Service Manual, please visit the Bunn-O-Matic website, at www.bunn.com. This is absolutely FREE, and the quickest way to obtain the latest catalog and manual updates. For Technical Service, contact Bunn-O-Matic Corporation at 1-800-286-6070.



BUNN-O-MATIC COMMERCIAL PRODUCT WARRANTY

Bunn-O-Matic Corp. ("BUNN") warrants the BUNN Crescendo as further described below for a warranty period of 1 year parts and labor.

These warranty periods run from the date of installation. BUNN warrants that the equipment manufactured by it will be commercially free of defects in material and workmanship existing at the time of manufacture and appearing within the applicable warranty period. This warranty does not apply to any equipment, component or part that was not manufactured by BUNN or that, in BUNN's judgment, has been affected by misuse, neglect, alteration, improper installation or operation, improper maintenance or repair, non periodic cleaning and descaling, equipment failures related to poor water quality, damage or casualty. This warranty is conditioned on the Buyer 1) giving BUNN prompt notice of any claim to be made under this warranty by telephone at (217) 529-6601 or by writing to Post Office Box 3227, Springfield, Illinois 62708-3227; 2) if requested by BUNN, shipping the defective equipment prepaid to an authorized BUNN service location; and 3) receiving prior authorization from BUNN that the defective equipment is under warranty. Additionally, the following is excluded from the warranty period:

Warranty Exclusions:

- Parts such as, but not limited to, hoppers and lids, drip trays, and plastic parts damaged due to improper handling or cleaning agents.
- Replacement of wear items such as, but not limited to, O-rings, gaskets, silicone tubes, hoses, and valve seats.
- Repairs made necessary due to poor water quality such as dispense valves, water inlet valves, scaling in the steam or hot water boilers. (Total Hardness recommended range of 4-7 gpg constant).
- Improper voltage. (See equipment operations manual for voltage specifications).
- Failure to use BUNN approved cleaning supplies constitutes improper maintenance.
- Failure to have required preventive maintenance performed by BUNN technician or authorized espresso service provider.
- Parts replaced under the terms of this warranty carry the remainder on the machine's parts warranty term, or 60 days, whichever is greater.

THE FOREGOING WARRANTY IS EXCLUSIVE AND IS IN LIEU OF ANY OTHER WARRANTY, WRITTEN OR ORAL, EXPRESS OR IMPLIED, INCLUDING, BUT NOT LIMITED TO, ANY IMPLIED WARRANTY OF EITHER MERCHANTABILITY OR FITNESS FOR A PARTICULAR PURPOSE. The agents, dealers or employees of BUNN are not authorized to make modifications to this warranty or to make additional warranties that are binding on BUNN. Accordingly, statements by such individuals, whether oral or written, do not constitute warranties and should not be relied upon. If BUNN determines in its sole discretion that the equipment does not conform to the warranty, BUNN, at its exclusive option while the equipment is under warranty, shall either 1) provide at no charge replacement parts and/or labor (during the applicable parts and labor warranty periods specified above) to repair the defective components, provided that this repair is done by a BUNN Authorized Service Representative; or 2) shall replace the equipment or refund the purchase price for the equipment.

THE BUYER'S REMEDY AGAINST BUNN FOR THE BREACH OF ANY OBLIGATION ARISING OUT OF THE SALE OF THIS EQUIPMENT, WHETHER DERIVED FROM WARRANTY OR OTHERWISE, SHALL BE LIMITED, AT BUNN'S SOLE OPTION AS SPECIFIED HEREIN, TO REPAIR, REPLACEMENT OR REFUND. In no event shall BUNN be liable for any other damage or loss, including, but not limited to, lost profits, lost sales, loss of use of equipment, claims of Buyer's customers, cost of capital, cost of down time, cost of substitute equipment, facilities or services, or any other special, incidental or consequential damages.

392, A Partner You Can Count On, Air Infusion, AutoPOD, AXIOM, BrewLOGIC, BrewMETER, Brew Better Not Bitter, BrewWISE, BrewWIZARD, BUNN Espresso, BUNN Family Gourmet, BUNN Gourmet, BUNN Pour-O-Matic, BUNN, BUNN with the stylized red line, BUNNlink, Bunn-O-Matic, Bunn-O-Matic, BUNNserve, BUNNSERVE with the stylized wrench design, Cool Froth, DBC, Dr. Brew stylized Dr. design, Dual, Easy Pour, EasyClear, EasyGard, FlavorGard, Gourmet Ice, Gourmet Juice, High Intensity, iMIX, Infusion Series, Intellisteam, My Café, Phase Brew, PowerLogic, Quality Beverage Equipment Worldwide, Respect Earth, Respect Earth with the stylized leaf and coffee cherry design, Safety-Fresh, vemycoffee.com, Scale-Pro, Silver Series, Single, Smart Funnel, Smart Hopper, SmartWAVE, Soft Heat, SplashGard, The Mark of Quality in Beverage Equipment Worldwide, ThermoFresh, Titan, trifecta, TRIFECTA (stylized logo), Velocity Brew, Air Brew, Beverage Bar Creator, Beverage Profit Calculator, Brew better not bitter., Build-A-Drink, BUNNsource, Coffee At Its Best, Cyclonic Heating System, Daypart, Digital Brewer Control, Element, Milk Texturing Fusion, Nothing Brews Like a BUNN, Picture Prompted Cleaning, Pouring Profits, Signature Series, Sure Tamp, Tea At Its Best, The Horizontal Red Line, Ultra are either trademarks or registered trademarks of Bunn-O-Matic Corporation. The commercial trifecta® brewer housing configuration is a trademark of Bunn-O-Matic Corporation.

TABLE OF CONTENTS

EXTERIOR COMPONENTS	4
PARTS BOX COMPONENTS	6
DOOR ASSEMBLY COMPONENTS	8
EXTERIOR DECALS	10
INTERIOR DECALS	12
GRINDER COMPONENTS.....	14
BREWER GROUP	16
POWDER GROUP - DRIVE COMPONENTS.....	18
POWDER GROUP - LEFT & MIDDLE HOPPER COMPONENTS	20
POWDER GROUP - RIGHT HOPPER COMPONENTS.....	22
POWDER GROUP - WHIPPER COMPONENTS	24
WATER GROUP - BOILER COMPONENTS.....	26
WATER GROUP - HOT WATER TANK COMPONENTS.....	28
HOSE GROUP - DELIVERY COMPONENTS	30
HOSE GRPUP - WATER/VENT/DRAIN COMPONETS (REAR)	32
HOSE GROUP - WATER/VENT/DRAIN COMPONETS (FRONT).....	34
ELECTRICAL COMPONENTS.....	36
NUMERICAL INDEX	40



EXTERIOR COMPONENTS

Crescendo

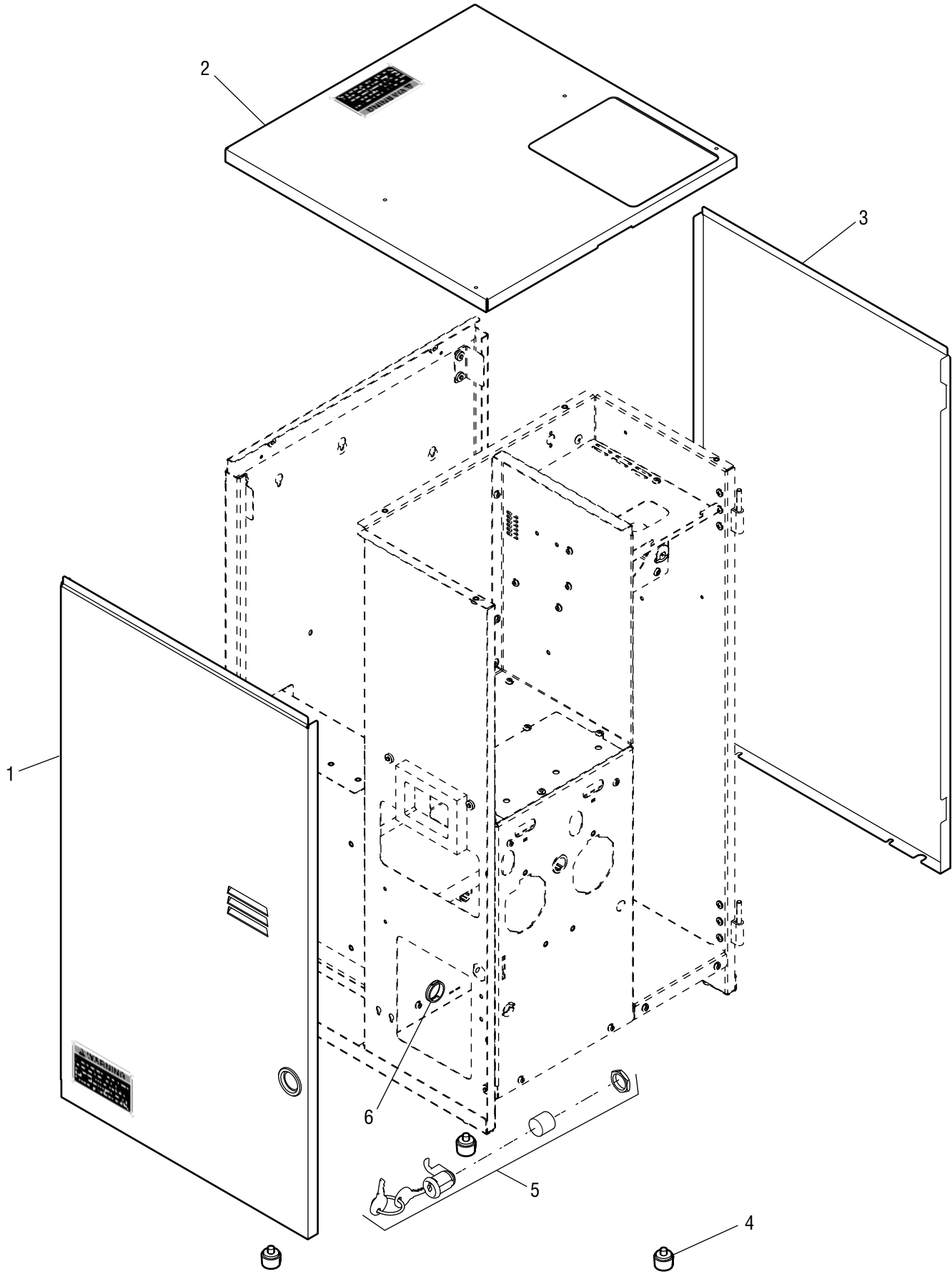

EXTERIOR COMPONENTS			
ITEM	PART NO.	QTY.	DESCRIPTION
1	49614.1002	1	Panel, Left Side w/Louvers and Warning Decal SST
2	50060.1012	1	Panel, Top Cover Black with Warning Label01 Panel, Top White
3	49614.1003	1	Panel, Right Side w/Warning Decal SST
4	25137.0001	4	Foot, Blk
5	34472.1001	1	Lock Assembly
6	27354.0000	1	Bushing, Snap .875 Dia.



PARTS BOX COMPONENTS

Crescendo

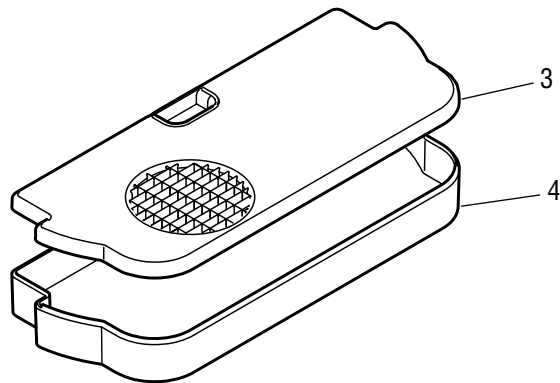
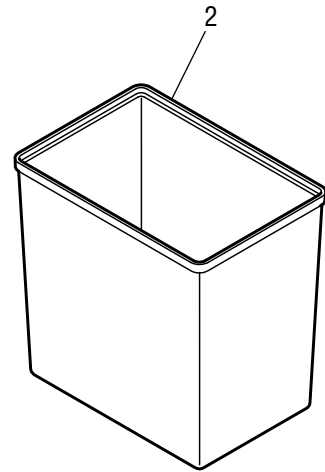
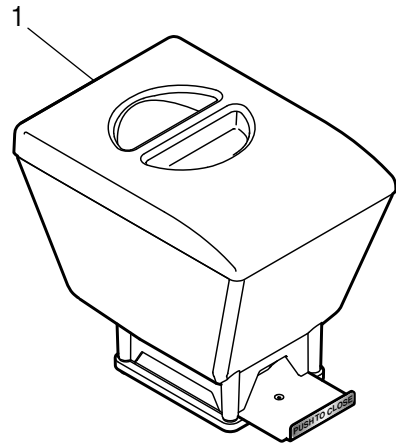
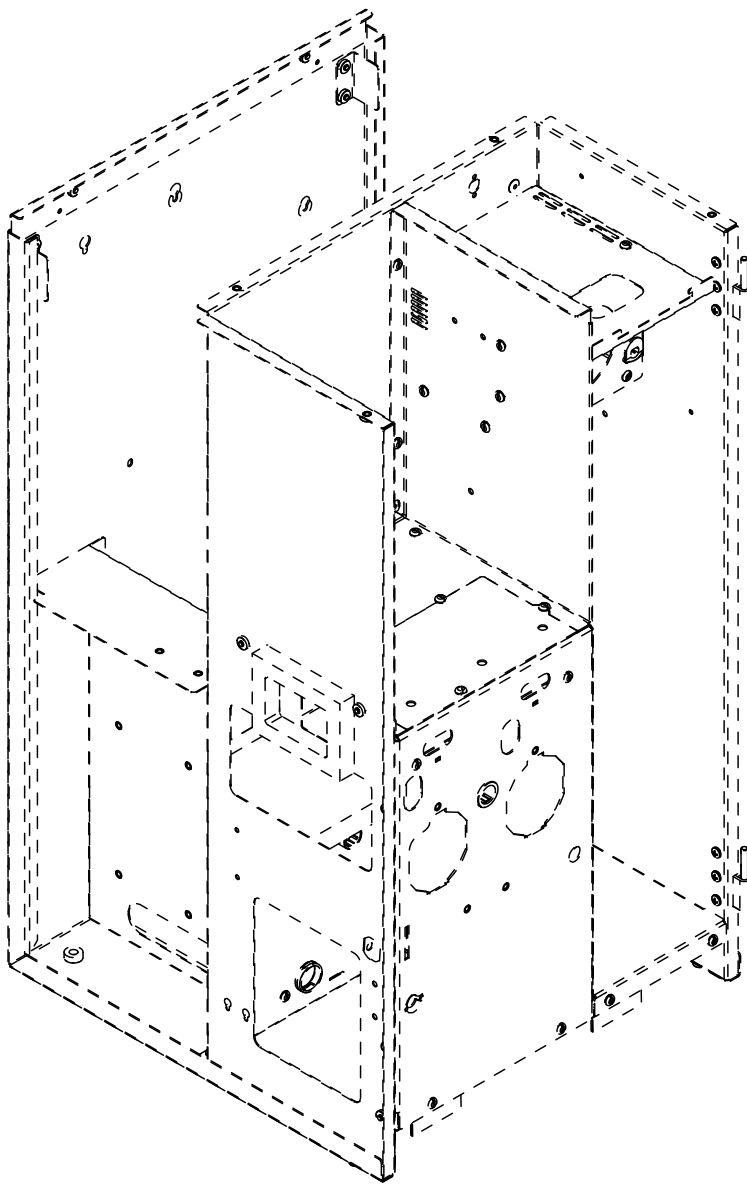

PARTS BOX COMPONENTS			
ITEM	PART NO.	QTY.	DESCRIPTION
1	50828.1010	1	Kit, Hopper Assy(CE)
	50828.1011	1	Kit, Hopper Assy (NSF)
2	50586.1000	1	Bin, Puck Assy
3	50074.0000	1	Cover, Drip Tray
4	52975.1000	1	Drip Tray Assy



DOOR COMPONENTS

Crescendo

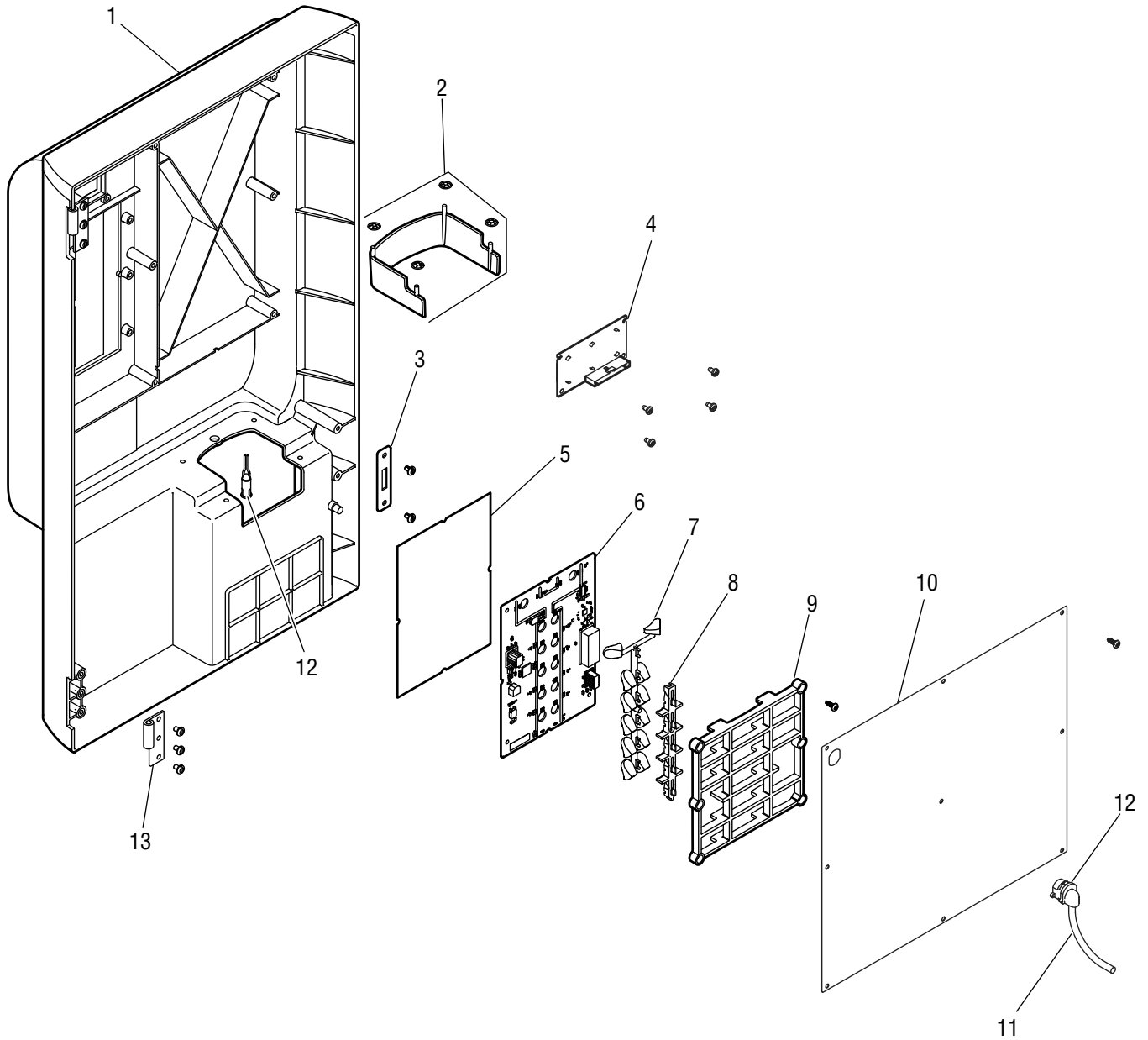

**DOOR COMPONENTS
DESCRIPTION**

ITEM	PART NO.	QTY.	DESCRIPTION
1	49951.1001	1	Door Assy, Crescendo
2	49949.1000	1	Bezel, Door
3	49774.0000	1	Catch, Door Lock
4	49360.0000	1	CBA, White LCD 2 X 16 Character
	01310.0000	4	Screw
5	51776.0000	1	Switch, Graphics (English)
	51776.8000	1	Switch, Graphics (Spanish)
6	51227.0001	1	Touchswitch, PCAP
7	52575.1000	1	Light Pipe w/Gasket
8	52504.0000	1	Baffle, Light Pipe
9	50866.0000	1	Bracket, PCAP CBA Retainer
	44224.0000	6	Screw
10	50851.0001	1	Panel, Inner Door
	44224.0000	9	Screw
11	51511.0000	1	Wire Harness, Door INTRC
12	47555.0000	1	Bushing, Strain Relief
13	49550.0001	2	Hinge
	32283.0001	6	Screw



EXTERIOR DECALS

Crescendo

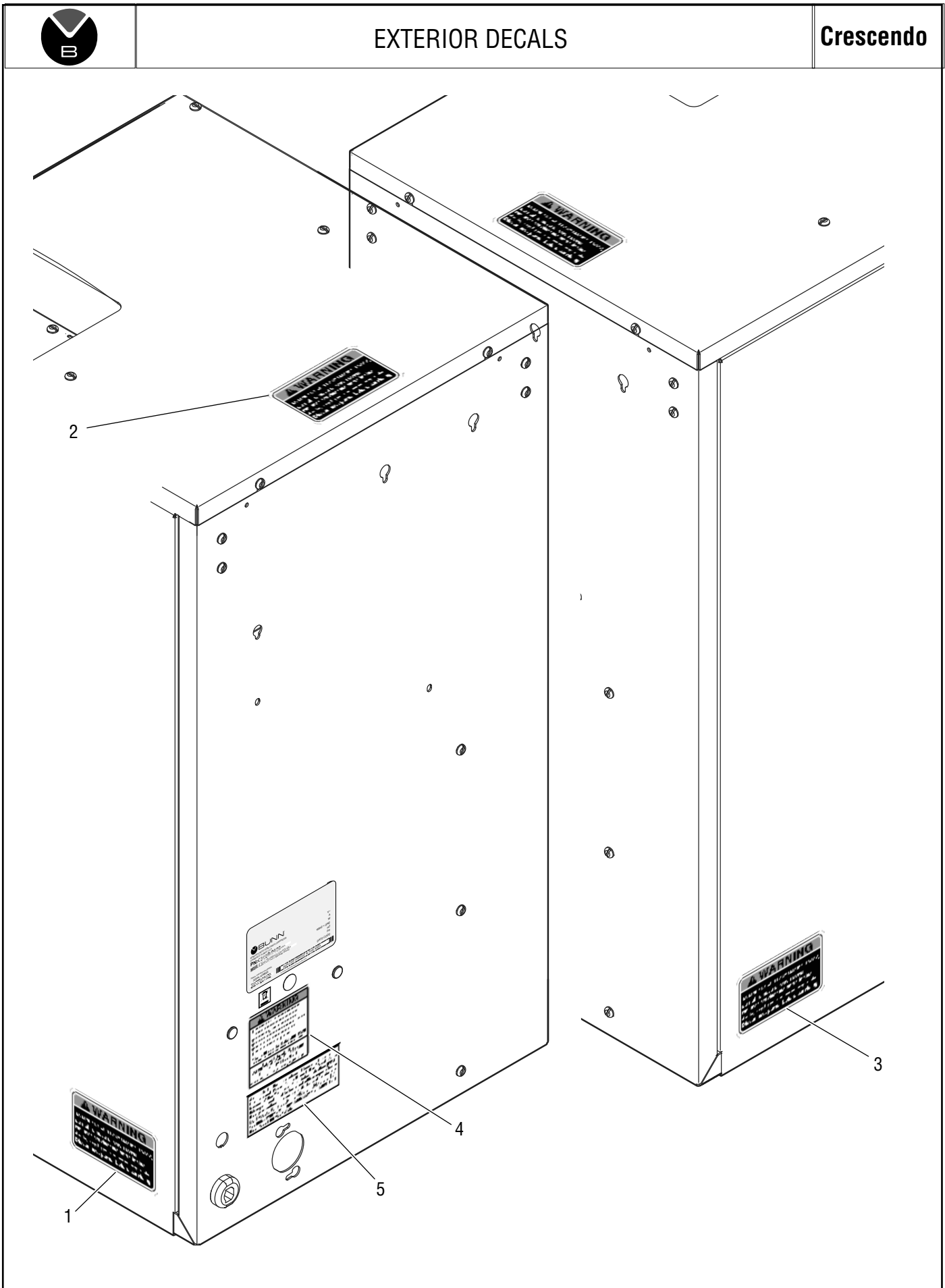

EXTERIOR DECALS
DESCRIPTION

ITEM	PART NO.	QTY.	DESCRIPTION
1	37881.0000	1	Decal, Warning No Service Parts
2	37881.0000	1	Decal, Warning No Service Parts
3	37881.0000	1	Decal, Warning No Service Parts
4	00986.0002	1	Decal, Warning Electrical
5	00656.0001	1	Decal, Comply To Plumbing Code



INTERIOR DECALS

Crescendo

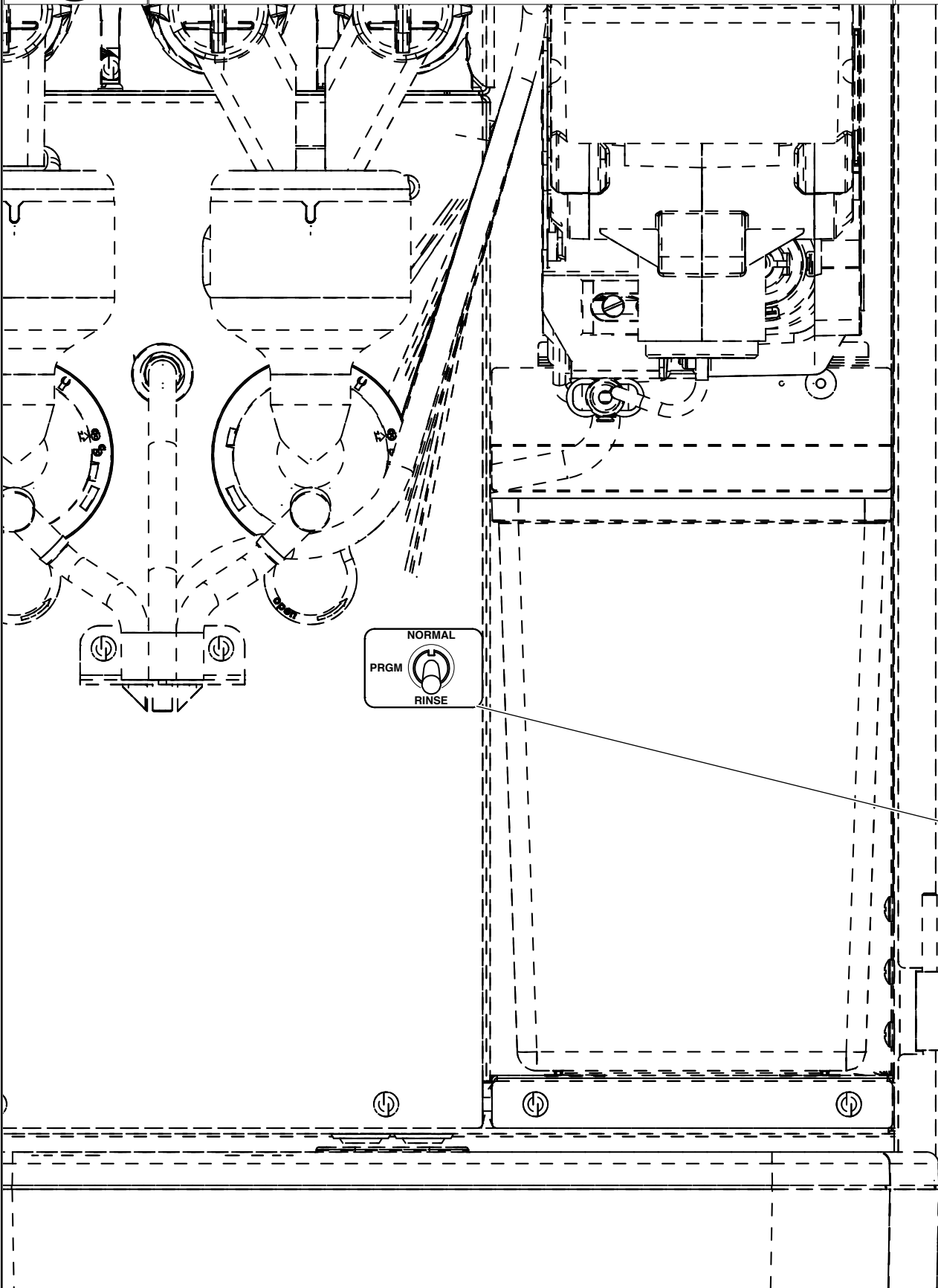

INTERIOR DECALS
DESCRIPTION

ITEM	PART NO.	QTY.	DESCRIPTION
1	44980.0000	1	Decal, Norm-Prog-Run



GRINDER COMPONENTS

Crescendo

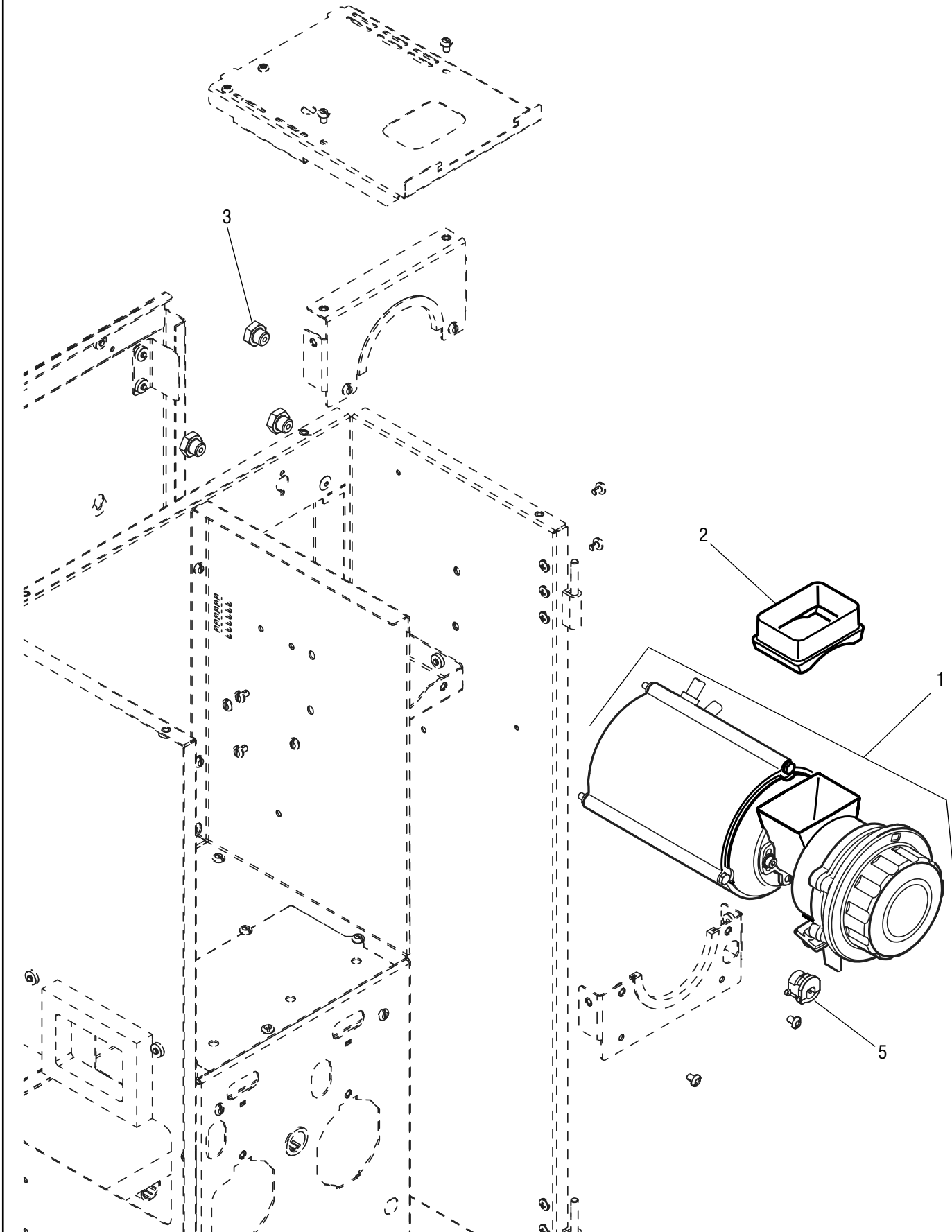

**GRINDER COMPONENTS
DESCRIPTION**

ITEM	PART NO.	QTY.	DESCRIPTION
1	53345.1001	1	Kit, Grinder/Knob Assy 120V (includes capacitor)
	53345.1000	1	Kit, Grinder/Knob Assy 230V (includes capacitor)
2	52038.0001	1	Collar, Bean Collector
3	50555.0001	3	Nut, Shoulder M4 x 7
4	02536.0001	3	Kit, Grommet (10/Kit) .375 ID (Not Shown)
5	47280.0001	1	Bushing, Strain Relief



BREWER COMPONENTS

Crescendo

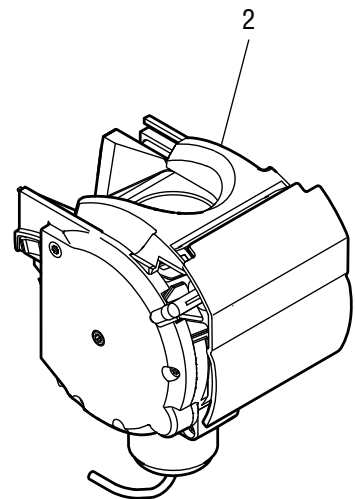
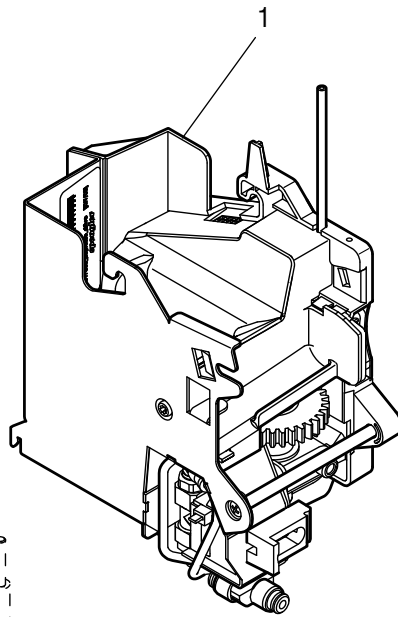
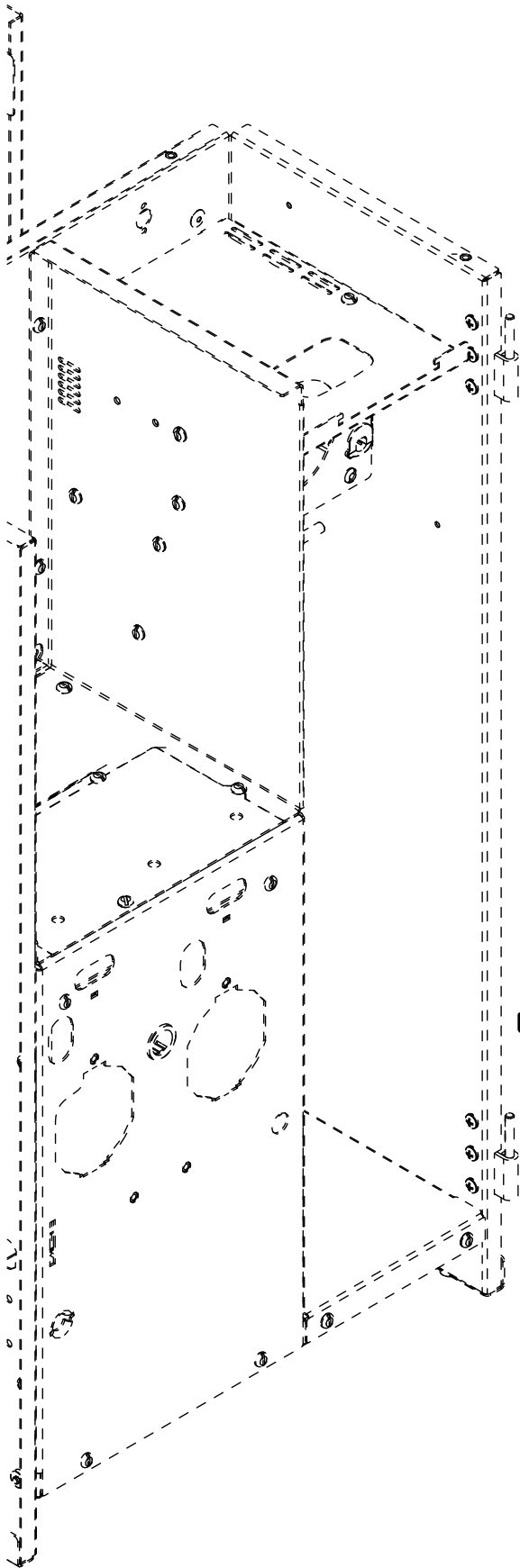

BREWER COMPONENTS			
ITEM	PART NO.	QTY.	DESCRIPTION
1	50583.0001	1	Drive, Motor - Espresso Group
2	50583.0002	1	Head, Brew - Espresso Group

The following items are not illustrated

3	50583.0010	1	Kit, Filter Brewer
4	50583.0011	1	Piston Head, Brewer
5	50583.0012	1	Wiper Blade, Brewer
6	50583.0013	1	Outlet, Brewer

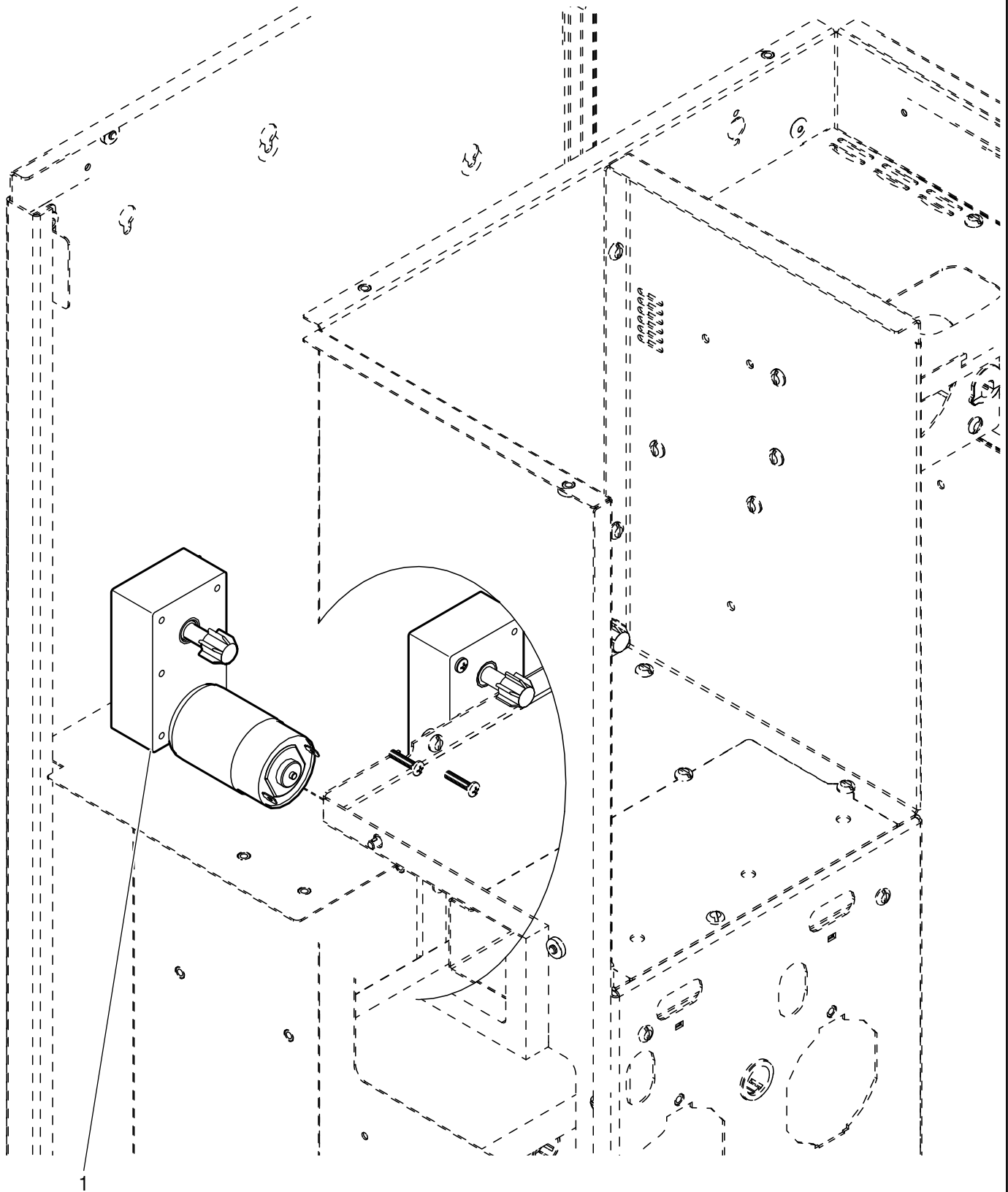

POWDER GROUP - DRIVE COMPONENTS
DESCRIPTION

ITEM PART NO.

QTY.

1

43583.1000

3

Kit, Gear Motor



POWDER GROUP - LEFT & MIDDLE HOPPER COMPONENTS

Crescendo

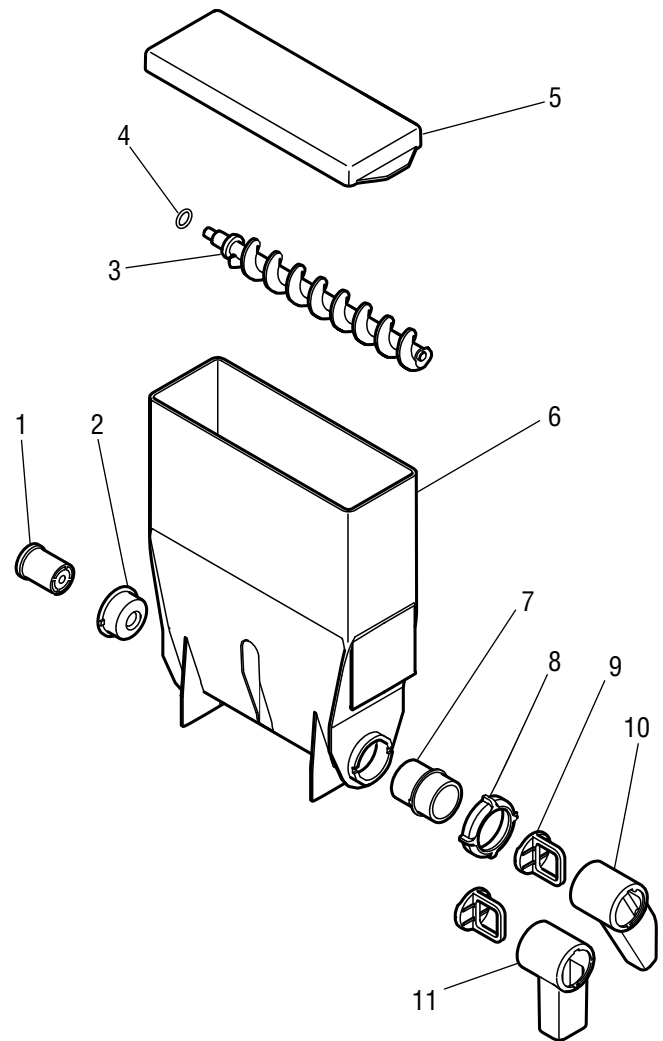
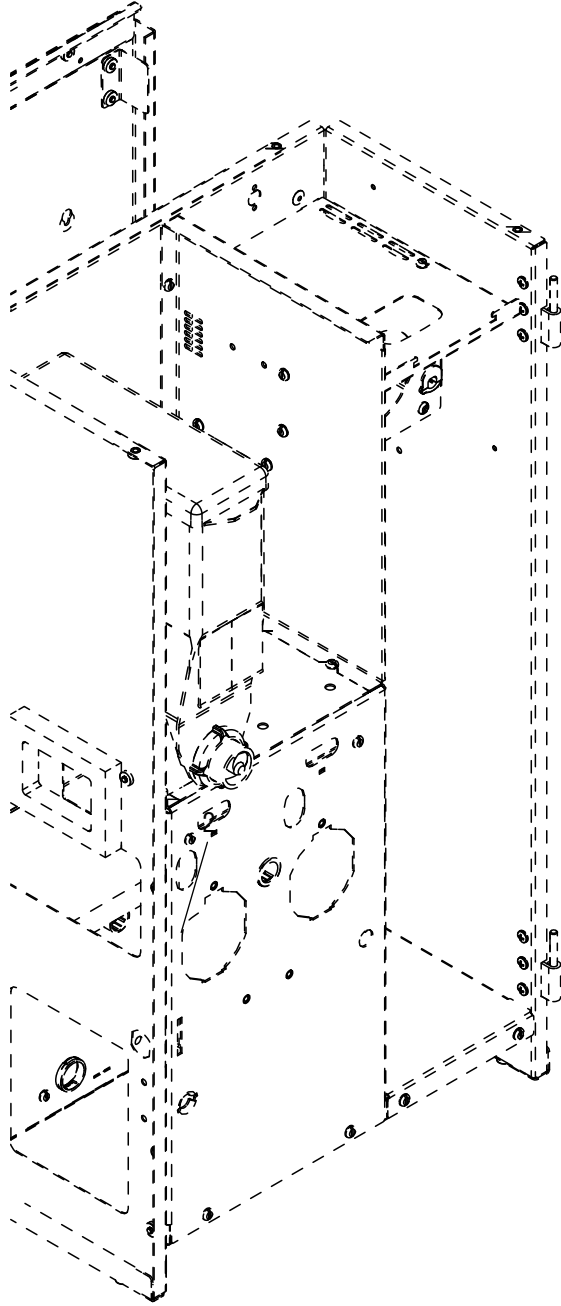

POWDER GROUP - LEFT & MIDDLE HOPPER COMPONENTS

ITEM	PART NO.	QTY.	DESCRIPTION
1	45155.0000	2	Coupler, Auger Drive
2	45153.0000	2	Flange, Rear Metal Shaft Auger
3	45154.0000	2	Auger, .74 Pitch w/Metal Shaft
4	45156.0000	2	O-Ring, Hopper Shaft Seal
5	50592.0002	2	Lid, Hopper - 67mm Wide
6	50592.0001	2	Body, Hopper - 67mm x 240mm HT
7	45058.0000	2	Bearing, Auger - Front
8	45049.0000	2	Nut, Auger Bearing - Front
9	49967.0000	2	Slide Gate, Soluble Hopper Closure
10	49966.0000	1	Elbow, Hopper with Closure - Center
11	49966.0001	1	Elbow, Hopper with Closure - Left



POWDER GROUP - RIGHT HOPPER COMPONENTS

Crescendo

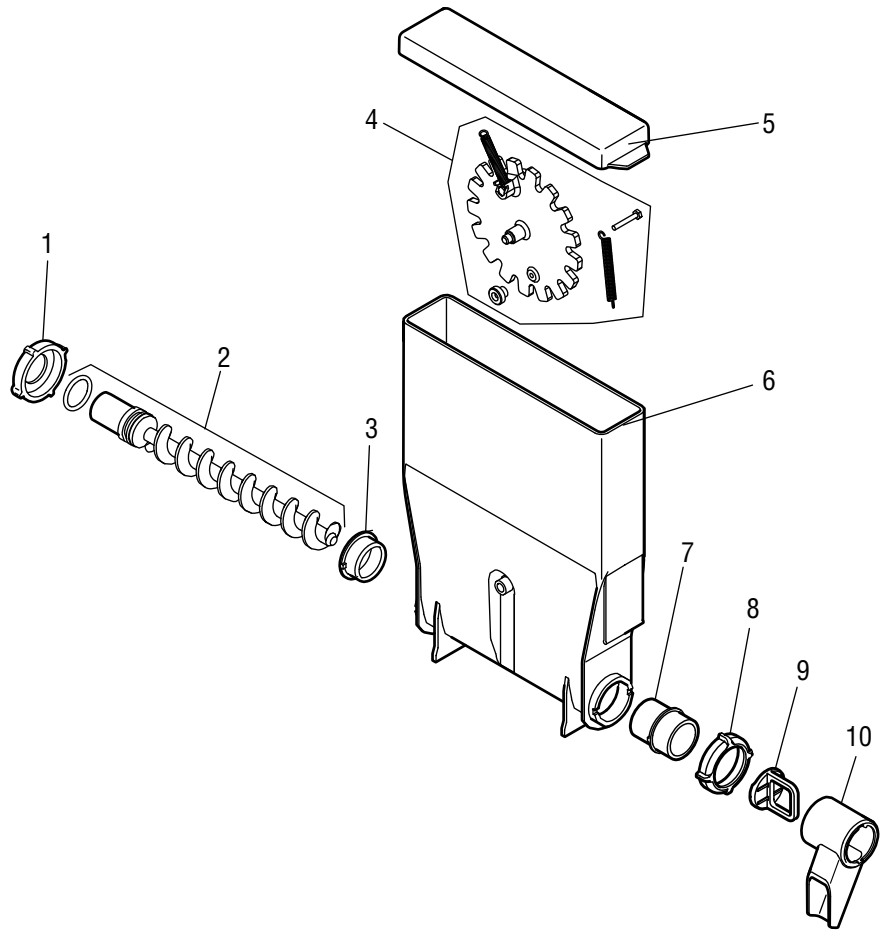
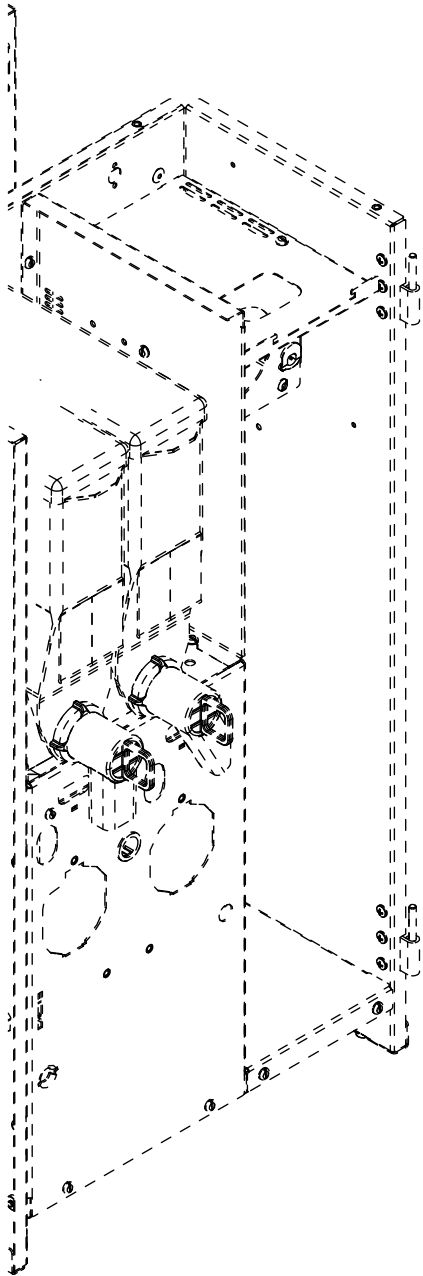

POWDER GROUP - RIGHT HOPPER COMPONENTS

ITEM	PART NO.	QTY.	DESCRIPTION
1	45052.0000	1	Nut, Auger Bearing - Rear
2	45051.0000	1	Auger, Hopper w/O-Ring
3	45050.0000	1	Bearing, Auger - Rear
4	45053.0000	1	Kit, Mixing Wheel Assy
5	45054.0000	1	Lid, Hopper - 67mm Wide
6	45047.0000	1	Body, Hopper - 45mm x 240mm HT
7	45058.0000	1	Bearing, Auger - Front
8	45049.0000	1	Nut, Auger Bearing - Front
9	49967.0000	1	Slide Gate, Soluble Hopper Closure
10	49966.0002	1	Elbow, Hopper with Closure - Right



POWDER GROUP - WHIPPER COMPONENTS

Crescendo

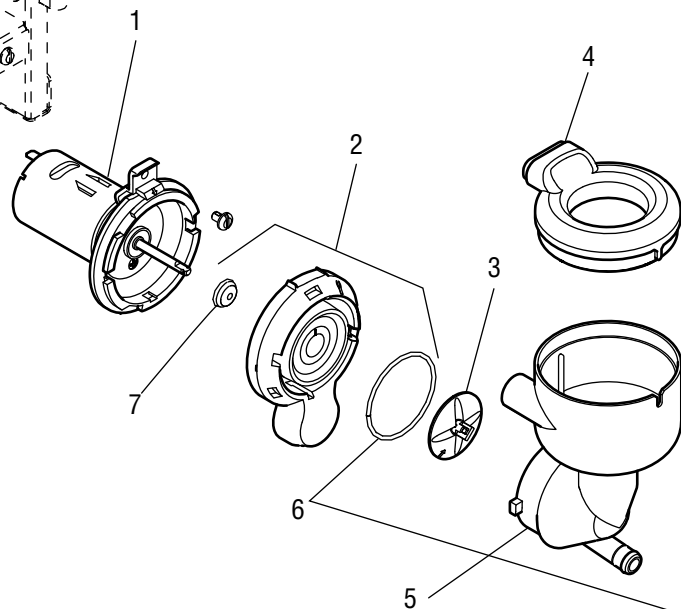
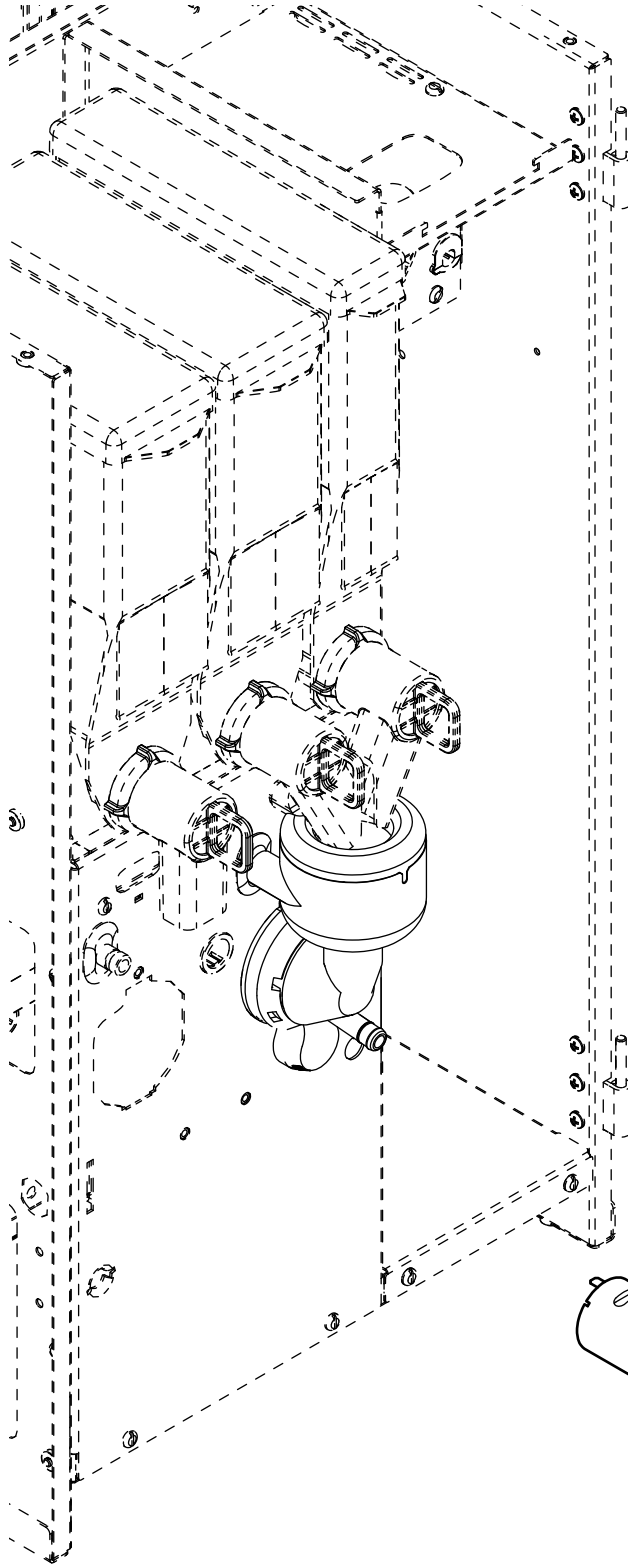

POWDER GROUP - WHIPPER COMPONENTS

ITEM	PART NO.	QTY.	DESCRIPTION
1	50596.0000	2	Whipper Motor
2	50595.0000	2	Base, Blender (Includes items 6 & 7)
3	50593.0000	2	Impeller, 4mm
4	50594.0000	2	Mixing Chamber - 247 Series
5	50597.0000	2	Steam Trap - 247 Series
6	50595.0001	2	O-Ring, 1.48 ID Blender Base
7	50595.0002	2	Gasket, Silicone Blender Base



WATER GROUP - BOILER COMPONENTS

Crescendo

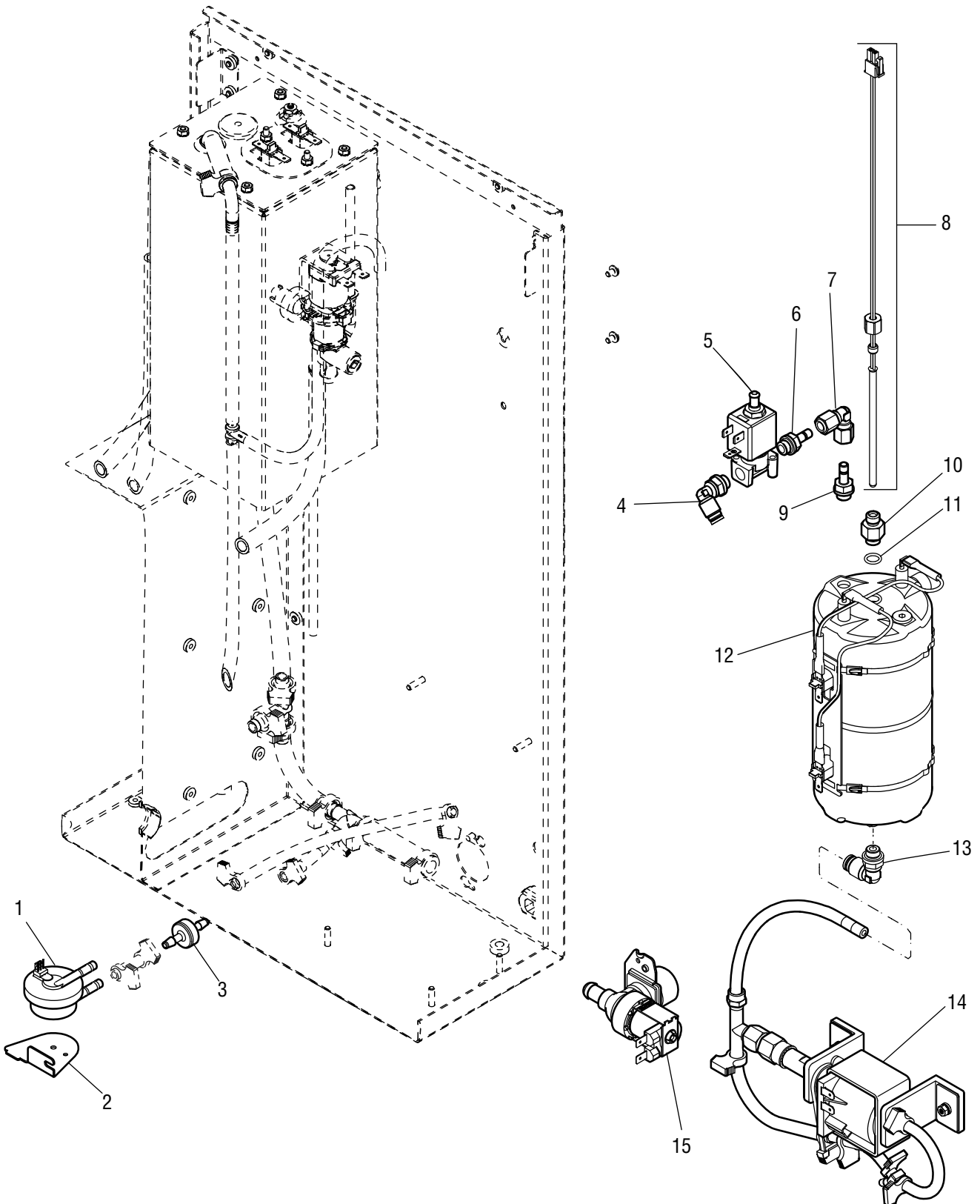

WATER GROUP - BOILER COMPONENTS

ITEM	PART NO.	QTY.	DESCRIPTION
1	36382.1001	1	Flowmeter, 1.2mm Oriface (includes push nut)
2	49619.0001	1	Bracket, Flow Meter MTG
3	50589.0000	1	Filter, In-Line 200Mesh .188 Barb
4	50405.0001	1	Elbow, Swvl .125BSPP to 4mm Push to Conn
5	50402.0000	1	Valve, Solenoid 3-Way 24VDC, .125BSPP
6	50406.0000	1	Fitting, Male Stand Pipe, .125 BSPP to 6mm
7	50407.0000	1	Elbow, Compression 6mm Equal
8	12568.1016	1	Kit, Temperature Probe, 7.38 LG (includes Ferrule Nut & Compression Ferrule)
9	50406.0000	1	Fitting, Male Stand Pipe, .125 BSPP to 6mm
10	49864.0001	1	Fitting, Connector, .125BSPP to .19CPRSN
11	24733.0001	1	O-Ring, -011 EP 70
12	46005.1001	1	Kit, Coffee Boiler
13	50403.0001	1	Elbow, Swvl .125BSPP to 6mm Push to Conn
14	50399.1001	1	Kit, Pump Assy, Solenoid 120V 60Hz w/Bypass
	50399.1000	1	Kit, Pump Assy, Solenoid 230V 50Hz w/Bypass
15	50050.0000	1	Valve, Inlet, .75 BSPP THDS 24VDC



WATER GROUP - HOT WATER TANK COMPONENTS

Crescendo

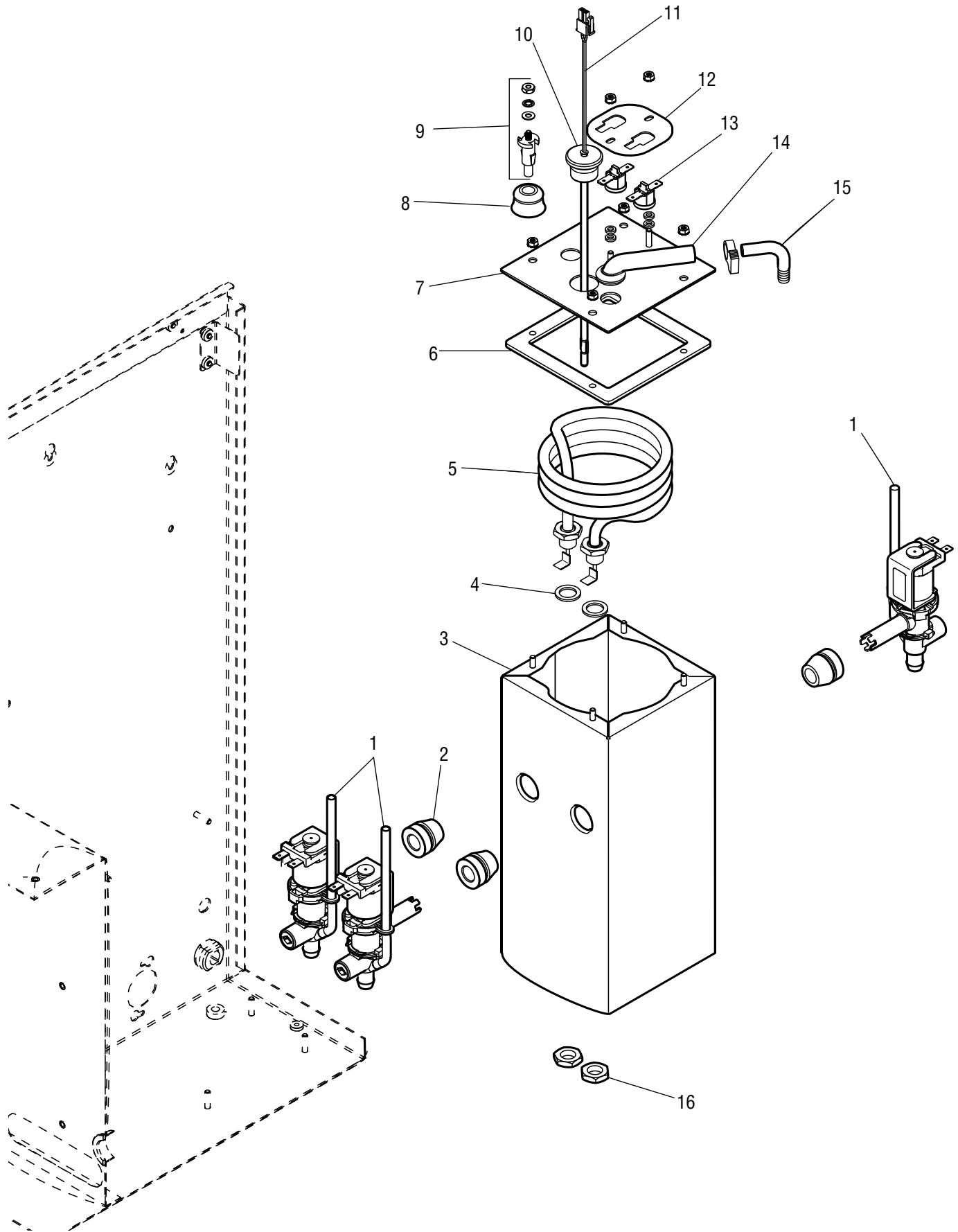

WATER GROUP - HOT WATER TANK COMPONENTS

ITEM	PART NO.	QTY.	DESCRIPTION
1	49936.0001	3	Valve, Dispense W/Flowctrl, 24VDC
2	49937.0000	3	Grommet, Dispense Valve, .47ID x .83OD
3	48411.0001	1	Tank, WLDMT, 1.5 GAL Three Valve
4	00943.0000	2	Gasket, Tank Heater
5	02756.0000	1	Heater, Tank, 1800W 120V
	02805.0000	1	Heater, Tank, 1850W 240V
6	50022.0001	1	Gasket, 4.5In Square Tank
7	51247.0000	1	Lid, Tank WLDMT 4.5 x 4.5
	47490.0000	4	Nut, Keps M4 SST
8	38114.0000	1	Grommet, Silicone w/Flange
9	07412.1003	1	Probe, Liquid Level (1.45 LG)
10	33801.0003	1	Grommet, Temp Sensor
11	38855.0000	1	Probe Assy, Temp WHT Pin1, 7.75 LG
12	46043.0002	1	Plate, Dual Thermal Limit Retainer
13	50291.0000	2	Thermostat, Sensata 221-239F, MNL Reset
14	38969.0003	1	Fitting, 90° Tank Vent, Silicon
15	34282.0000	1	Elbow, SST .312 Hose ID One End
16	00942.0000	2	Nut, Hex, Brass 500-20



HOSE GROUP - DELIVERY COMPONENTS

Crescendo

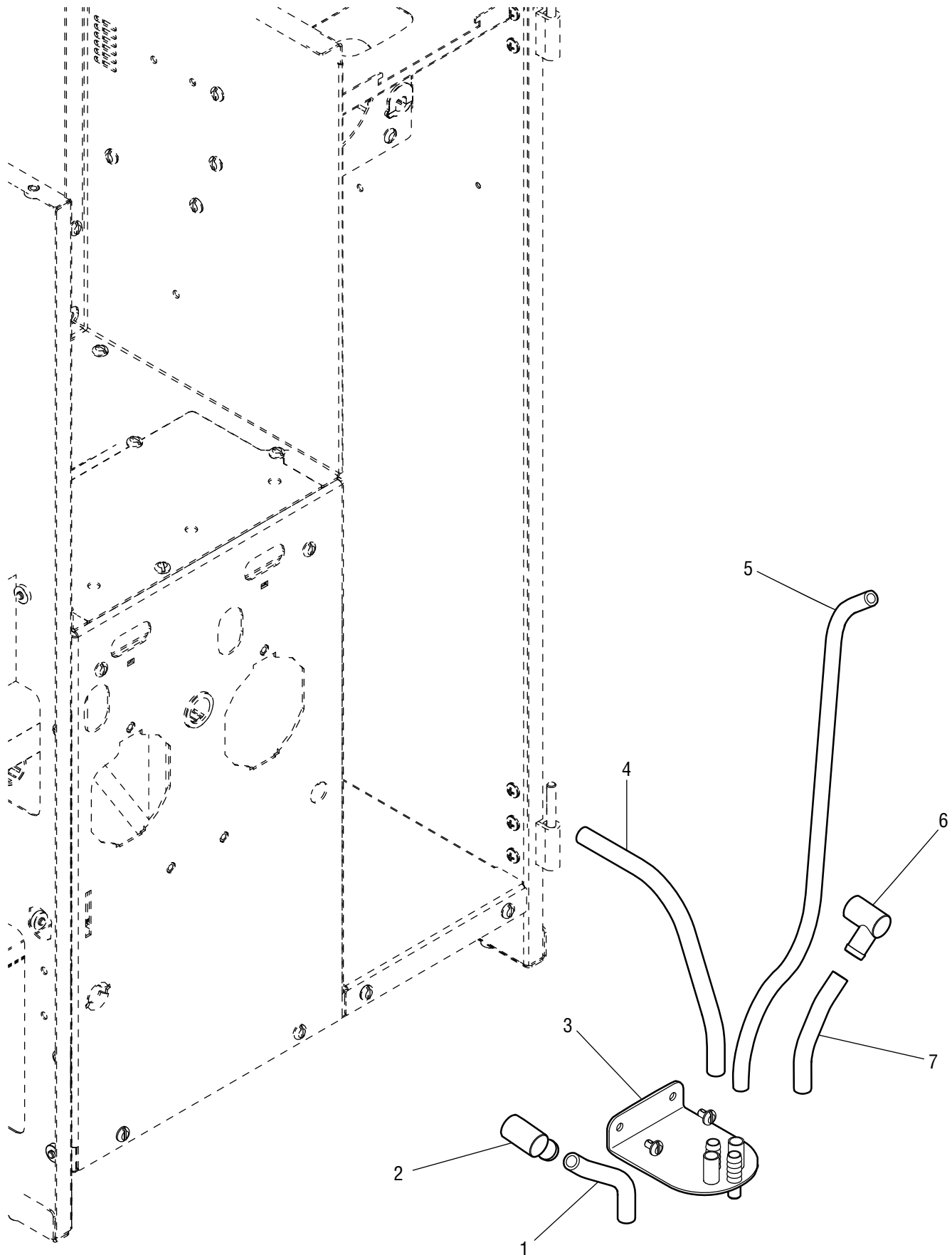

HOSE GROUP - DELIVERY COMPONENTS

ITEM	PART NO.	QTY.	DESCRIPTION
1		1	Tube, Silicone 6mm ID x 2.6" (order item 8)
2	39312.0000	1	Fitting, Outlet Pipe SLCC-6
3	50688.0000	1	Bracket, Assy Outlet
4		1	Tube, Silicone 6mm ID x 6.5" (order item 8)
5		1	Tube, Silicone 5mm ID x 12.0" (order item 9)
6	39312.0000	1	Fitting, Outlet Pipe SLCC-6
7		1	Tube, Silicone 6mm ID x 2.6" (order item 8)

The following items are not illustrated

8	50732.1001	-	Tube, Silicone 6mm ID x 36.0" (Use as required)
9	50733.1001	-	Tube, Silicone 5mm ID x 36.0" (Use as required)



HOSE GROUP - WATER/VENT/DRAIN COMPONENTS (REAR)

Crescendo

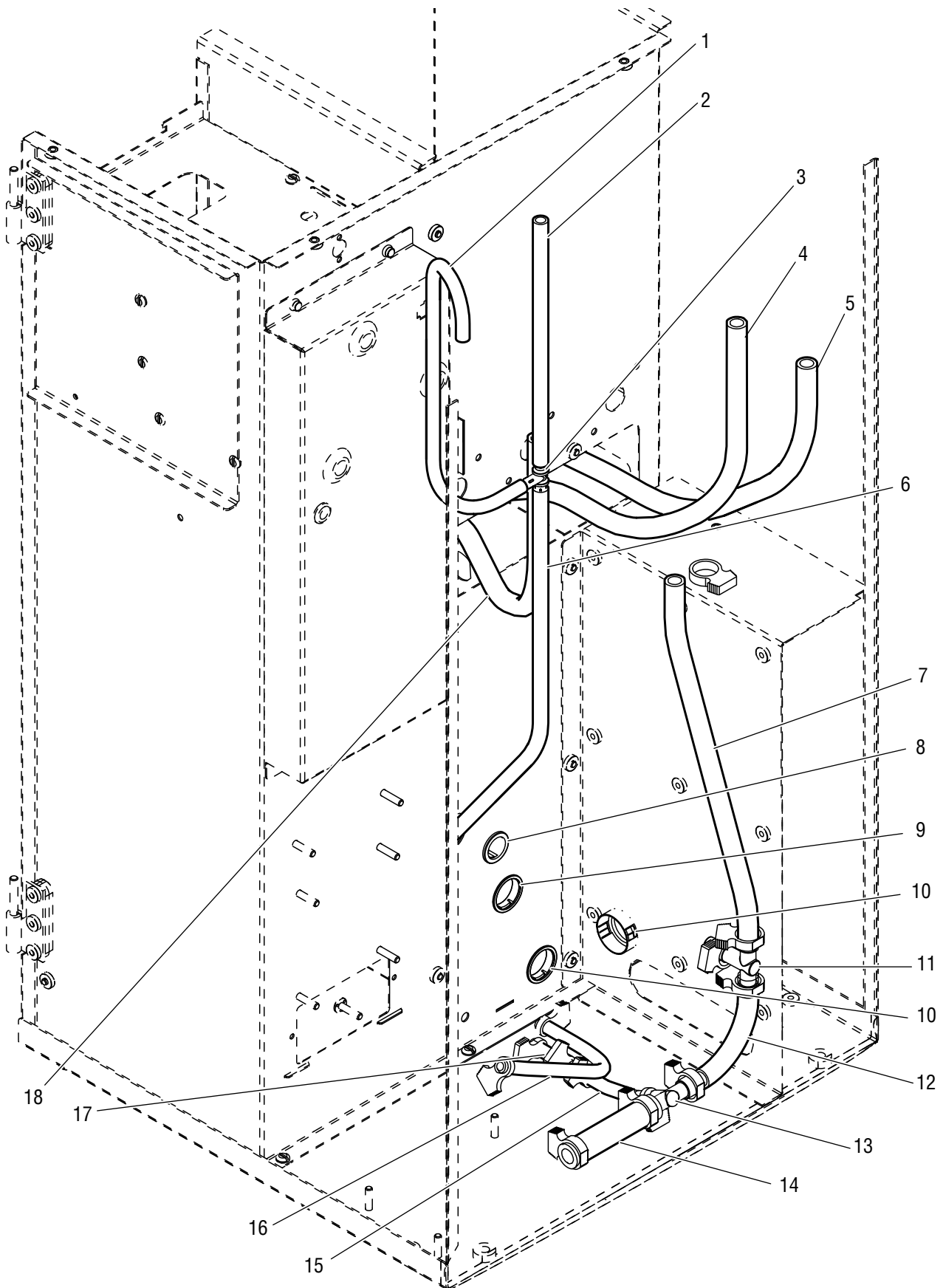

HOSE GROUP - WATER/VENT/DRAIN COMPONENTS (REAR)

ITEM	PART NO.	QTY.	DESCRIPTION
1		1	Tube, Silicone 5mm ID x 14.0" (order item 21)
2		1	Tube, Silicone 6mm ID x 6.8" (order item 20)
3	42775.0000	1	Tee, Fitting .250" x .250" x .250"
4		1	Tube, Silicone 8mm ID x 14.5" (order item 19)
5		1	Tube, Silicone 8mm ID x 16.4" (order item 19)
6		1	Tube, Silicone 6mm ID x 18.7" (order item 20)
7		1	Tube, Silicone 8mm ID x 9.0" (order item 19)
8	07070.0000	1	Bushing, Snap .687 Dia. MTG
9	27354.0000	2	Bushing, Snap .875 Dia. MTG
10	01592.0000	1	Bushing, Snap 1.0 Dia. MTG
11	38948.0001	1	Fitting, Tee .375" Barb - PVDF
12		1	Tube, Silicone 8mm ID x 6.0" (order item 19)
13	50557.0000	1	Tee, .18" x .38" x .38" Barbed PVDF
14		1	Tube, Silicone .375" x 2.75" (order item 22)
15		1	Tube, Silicone 5mm ID x 2.2" (order item 21)
16		1	Tube, Silicone 5mm ID x 17.0" (order item 21)
17		1	Tube, Silicone 5mm ID x 1.25" (order item 21)
18		1	Tube, Silicone 8mm ID x 17.0" (order item 19)

The following items are not illustrated

19	50731.BULK	-	Tube, Silicone 8mm ID x 36.0" (Use as required)
20	50732.1001	-	Tube, Silicone 6mm ID x 36.0" (Use as required)
21	50733.1001	-	Tube, Silicone 5mm ID x 36.0" (Use as required)
22	20976.BULK	-	Tube, Silicone .375" ID x 12.0" (Use as required)



HOSE GROUP - WATER/VENT/DRAIN COMPONENTS (FRONT)

Crescendo

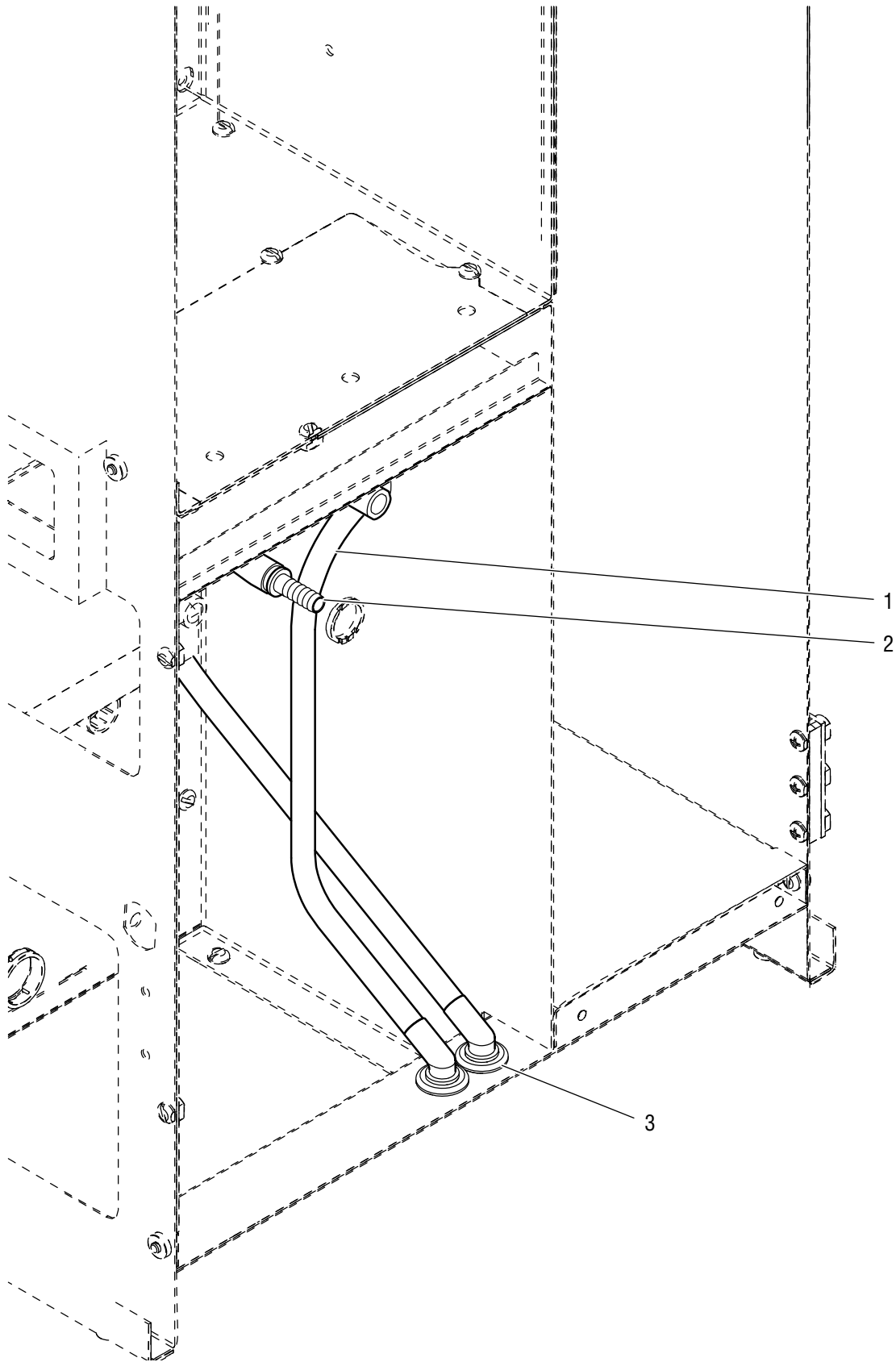

HOSE GROUP - WATER/VENT/DRAIN COMPONENTS (FRONT)

ITEM	PART NO.	QTY.	DESCRIPTION
1		1	Tube, Silicone 6mm ID x 6.8" (order item 4)
2	26443.0001	1	Fitting, Union -SST Barbed .25" x .38" Hose
3	32655.0000	2	Fitting, 60 Degree Elbow .25" Barb

The following items are not illustrated

4	50732.1001	-	Tube, Silicone 6mm ID x 36.0" (Use as required)
---	------------	---	---

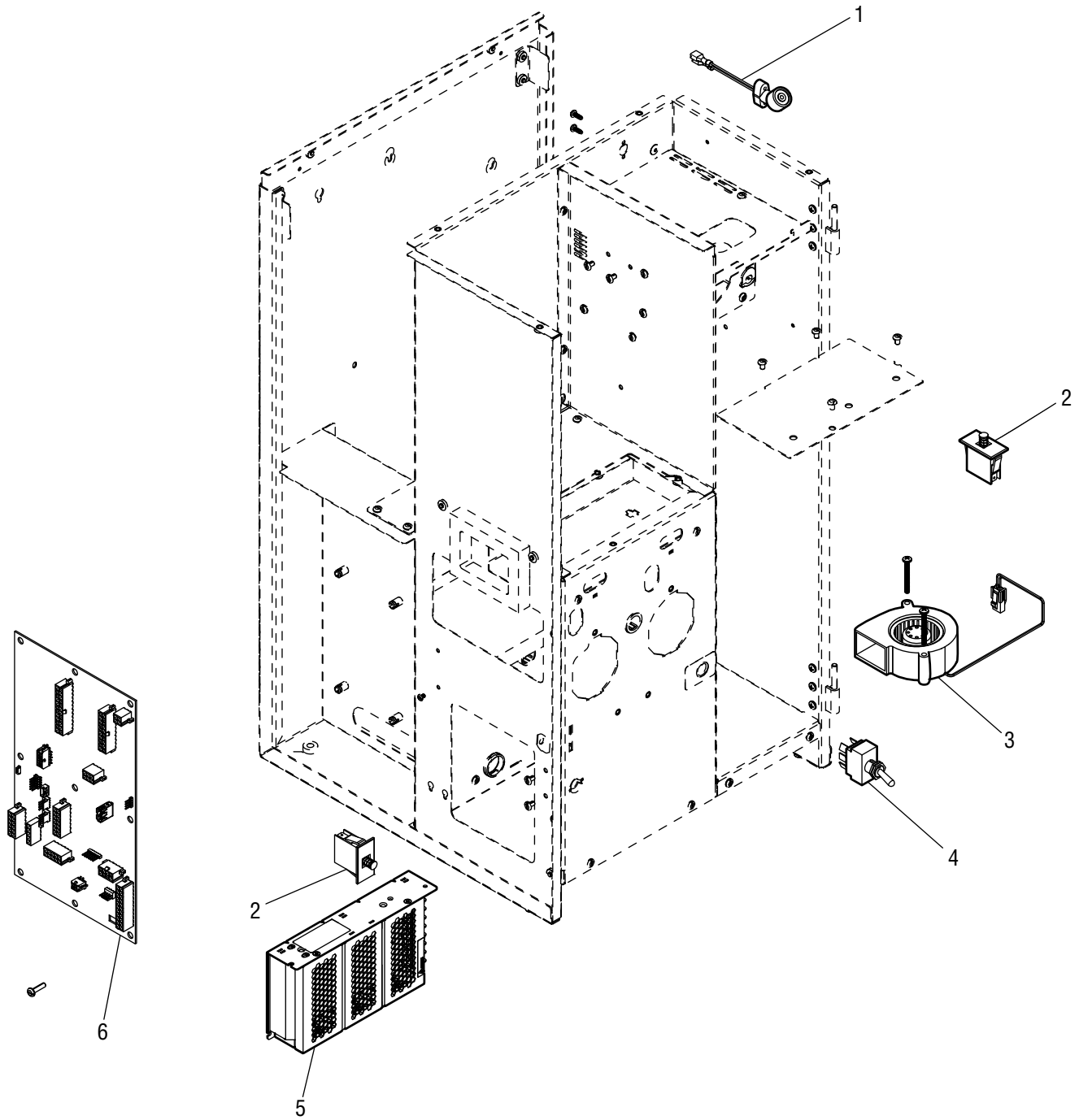

ELECTRICAL COMPONENTS			
ITEM	PART NO.	QTY.	DESCRIPTION
1	50582.1002	1	Photoresister & Housing Assembly
2	50573.0000	2	Switch, Interupt SPST-NO SPST-NC
3	50569.0000	1	Fan Assy, Blower 75mm with Terminals
4	28857.0000	1	Switch, Toggle Rinse/Program
5	33363.0007	1	Power Supply, 24VDC 6.25A 150W 1 Phase
6	50632.1000	1	CBA, Control

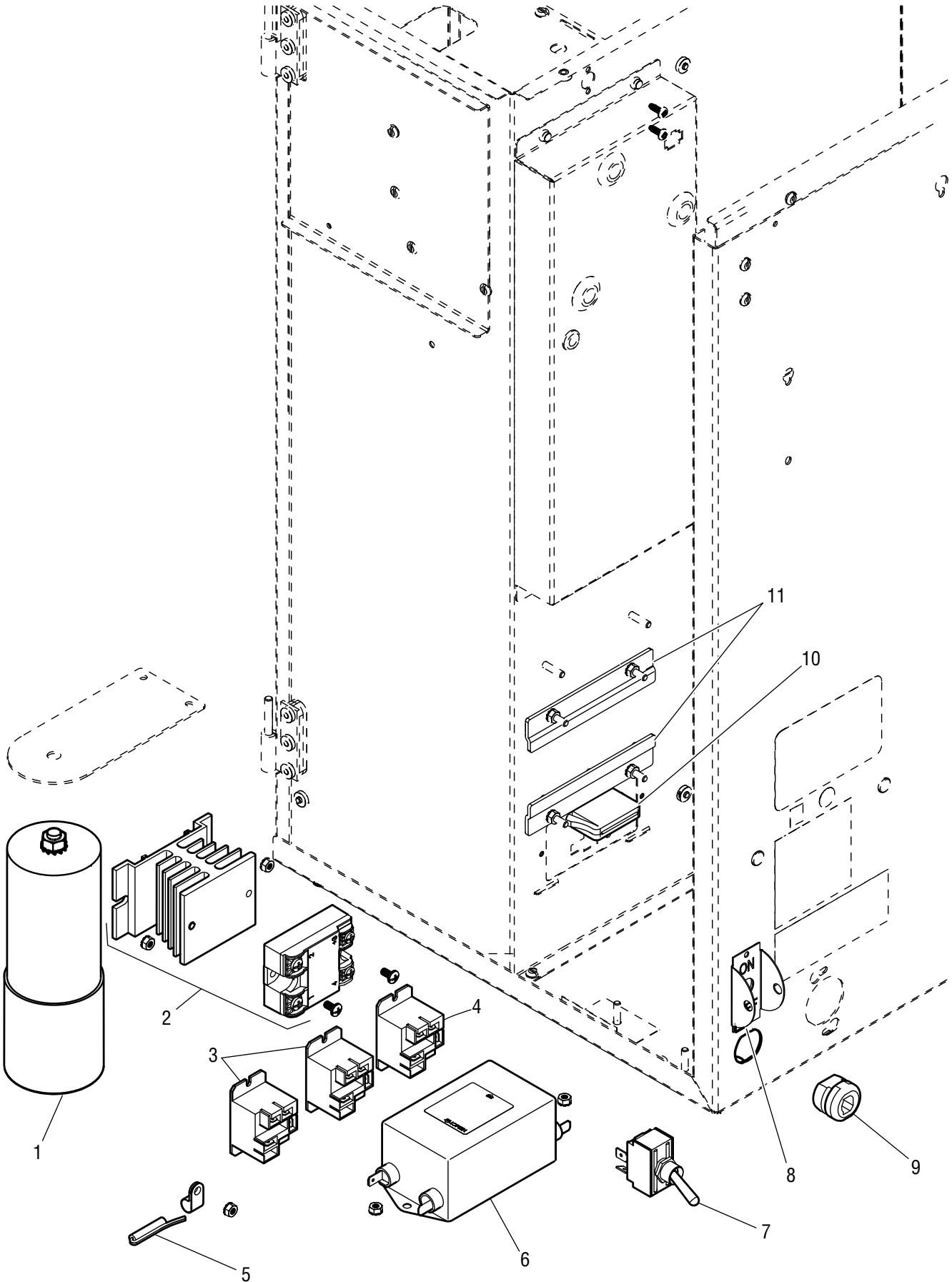

ELECTRICAL COMPONENTS - Continued

ITEM	PART NO.	QTY.	DESCRIPTION
1	53345.1001	1	Kit, Grinder/Knob/Capacitor (120V - also shown on pg 14)
	53345.1000	1	Kit, Grinder/Knob/Capacitor (230V - also shown on pg 14)
2	49266.0000	1	Relay, Solid State MCO w/ Heat Sink
3	32104.0001	2	Relay, 24V Coil
4	32104.0002	1	Relay, SPDT 24VDC Coil
5	36390.0001	1	Switch Assy, Reed w/Leads and Terminals
6	36801.0001	1	Filter, EMI 15 120/250 VAC (CE Only)
7	40763.0001	1	Switch, Toggle DPST
8	25102.0000	1	Bracket, Switch Indicator Guard
9	01686.0000	1	Bushing, Strain RLF-STR (7K-2)
10	25899.0000	1	Magnetic Catch, Snap-In
11	50073.0000	2	Clip, Relay Mounting

The following items are not illustrated

12	20630.0008	1	Cord Assy, PWR 120V
13	33529.0006	1	Cord Assy, PWR 230V
14	51171.0000	1	Wiring Harness, Switch to EMI Filter
15	51165.0001	1	Wiring Harness, Power
16	51166.0000	1	Wiring Harness, 24VDC Output
17	51167.0000	1	Wiring Harness, Control Input
18	51168.0000	1	Wiring Harness, Espresso Group Interconnect
19	51169.0000	1	Wiring Harness, Espressor Group to CBA

NUMERICAL INDEX

PART NO.	PAGE NO.	PART NO.	PAGE NO.	PART NO.	PAGE NO.	PART NO.	PAGE NO.
00656.0001.....	11	45155.0000.....	21	50595.0001.....	25		
00942.0000.....	29	45156.0000.....	21	50595.0002.....	25		
00943.0000.....	29	46005.1001.....	27	50596.0000.....	25		
00986.0002.....	11	46043.0002.....	29	50597.0000.....	25		
01310.0000.....	9	47280.0001.....	15	50632.1000.....	37		
01592.0000.....	33	47490.0000.....	29	50688.0000.....	31		
01686.0000.....	39	47555.0000.....	9	50732.1001.....	31		
02536.0001.....	15	48411.0001.....	29	50731.BULK.....	33		
02756.0000.....	29	49266.0000.....	39	50733.1001.....	31		
02805.0000.....	29	49360.0000.....	9	50732.1001.....	33		
07070.0000.....	33	49550.0001.....	9	50733.1001.....	33		
07412.1003.....	29	49614.1002.....	5	50732.1001.....	35		
12568.1016.....	27	49614.1003.....	5	50828.1010.....	7		
20630.0008.....	39	49619.0001.....	27	50828.1011.....	7		
20976.BULK.....	33	49774.0000.....	9	50851.0001.....	9		
24733.0001.....	27	49864.0001.....	27	50866.0000.....	9		
25102.0000.....	39	49949.1000.....	9	51165.0001.....	39		
25137.0001.....	5	49951.1001.....	9	51166.0000.....	39		
25899.0000.....	39	49936.0001.....	29	51167.0000.....	39		
26443.0001.....	35	49937.0000.....	29	51168.0000.....	39		
27354.0000.....	5, 33	49966.0000.....	21	51169.0000.....	39		
28857.0000.....	37	49966.0001.....	21	51171.0000.....	39		
32104.0001.....	39	49967.0000.....	21	51227.0001.....	9		
32104.0002.....	39	49966.0002.....	23	51247.0000.....	29		
32283.0001.....	9	49967.0000.....	23	51511.0000.....	9		
32655.0000.....	35	50022.0001.....	29	51776.0000.....	9		
33363.0007.....	37	50060.1012.....	5	51776.8000.....	9		
33529.0006.....	39	50050.0000.....	27	52038.0001.....	15		
33801.0003.....	29	50074.0000.....	7	52504.0000.....	9		
34282.0000.....	29	50073.0000.....	39	52575.1000.....	9		
34472.1001.....	5	50291.0000.....	29	52975.1000.....	7		
36382.1001.....	27	50399.1000.....	27	53345.1000.....	15,39		
36390.0001.....	39	50399.1001.....	27	53345.1001.....	15,39		
36801.0001.....	39	50402.0000.....	27				
37881.0000.....	11	50403.0001.....	27				
38114.0000.....	29	50405.0001.....	27				
38855.0000.....	29	50406.0000.....	27				
38948.0001.....	33	50407.0000.....	27				
38969.0003.....	29	50555.0001.....	15				
39312.0000.....	31	50557.0000.....	33				
40763.0001.....	39	50582.1002.....	37				
42775.0000.....	33	50583.0001.....	17				
43583.1000.....	19	50583.0002.....	17				
44224.0000.....	9	50583.0010.....	17				
44980.0000.....	13	50583.0011.....	17				
45049.0000.....	21	50583.0012.....	17				
45047.0000.....	23	50583.0013.....	17				
45049.0000.....	23	50569.0000.....	37				
45050.0000.....	23	50573.0000.....	37				
45051.0000.....	23	50586.1000.....	7				
45052.0000.....	23	50589.0000.....	27				
45053.0000.....	23	50592.0001.....	21				
45054.0000.....	23	50592.0002.....	21				
45058.0000.....	21	50593.0000.....	25				
45153.0000.....	21	50594.0000.....	25				
45154.0000.....	21	50595.0000.....	25				