



OPERATION MANUAL

HD COOKLINE SERIES GAS COUNTERTOP GRIDDLES WITH MANUAL CONTROLS

SERIES: BPHMG



BUILT BY CRAFTSMEN. TESTED BY TIME®



MANUAL HEAVY DUTY GAS GRIDDLE OPERATION MANUAL

MANUAL HEAVY DUTY GAS GRIDDLE OPERATION MANUAL

Manual Heavy Duty Gas Griddle Models:
BPMG-2424i, BPHMG-2436i, BPHMG-2448i, BPHMG-2460i, BPHMG-2472i

Bakers Pride Oven Company, LLC is a wholly owned subsidiary of Standex International Corporation.

All gas operated Bakers Pride® griddles are intended for use with the type of gas specified on the rating plate and for installation will be in accordance with National Fuel Gas Code ANSI Z223.1 (latest edition).

Warning box: WARNING. FOR YOUR SAFETY: Do not store or use gasoline or other flammable vapors or liquids in the vicinity of this or any other appliance.

Warning box: WARNING. Improper installation, adjustment, alteration, service or maintenance can cause property damage, injury or death. Read the installation, operating and maintenance instructions thoroughly before installing or servicing this equipment.

Warning box: WARNING. Instructions must be posted in a prominent location. All safety precautions must be taken in the event the user smells gas. Safety information can be obtained from your local gas supplier.

Please complete this information and retain this manual for the life of the equipment. For Warranty Service and/or Parts, this information is required.

Model Number

Serial Number

Date Purchased



BAKERS PRIDE OVEN COMPANY, LLC.
1307 N. Watters Rd., Suite 180
Allen, TX 75013

Phone: 800.527.2100 | Fax: 914.576.0605 | www.bakerspride.com



TABLE OF CONTENTS

| | |
|--|----|
| SAFETY PRECAUTIONS | 3 |
| GENERAL INSTALLATION INSTRUCTIONS | 4 |
| SPECIFICATIONS & DIMENSIONS | 5 |
| CONVERSION | 8 |
| LIGHTING INSTRUCTIONS | 9 |
| OPERATING INSTRUCTIONS | 10 |
| CLEANING/MAINTENANCE | 11 |
| SERVICE/REPAIR | 11 |
| TROUBLESHOOTING GUIDE | 12 |
| REPLACEMENT PARTS LISTS & EXPLODED VIEWS | 13 |
| WARRANTY | 19 |

INTRODUCTION

⚠ CAUTION

These models are designed, built, and sold for commercial use. If these models are positioned so the general public can use the equipment, make sure that cautions, warnings, and operating instructions are clearly posted near each unit so that anyone using the equipment will use it correctly and not injure themselves or harm the equipment.

⚠ WARNING

Improper installation, adjustment, alteration, service or maintenance can cause property damage, injury or death. Read the installation, operating and maintenance instructions thoroughly before installing or servicing this equipment.

⚠ WARNING

For your safety do not store or use gasoline or other flammable vapors and liquids in the vicinity of this or any other appliance. Keep the area free and clear of combustibles. (See ANZI Z83. 14B, 1991).

NOTICE

Instructions to be followed if anyone smells gas should be posted in a prominent place. These may be obtained from the gas supplier.

GAS PRESSURE

The appliance and its individual shutoff valve (to be supplied by user) must be disconnected from the gas supply piping system during any pressure testing of that system at test pressures in excess of ½ psi (3.45 kPa).

NOTE: Gas shutoff valve is supplied on CE models.

The appliance must be isolated from the gas supply piping system by closing its individual manual shut-off valve during any pressure testing of the gas supply piping system at test pressures equal to or less than ½ psi (3.45 kPa).

⚠ WARNING

A factory authorized agent should handle all maintenance and repair. Before doing any maintenance or repair, contact Bakers Pride.



INTRODUCTION

Congratulations on your purchase of Bakers Pride® commercial cooking equipment. Bakers Pride takes pride in the design and quality of our products. When used as intended and with proper care and maintenance, you will experience years of reliable operation from this equipment. To ensure best results, it is important that you read and follow the instructions in this manual carefully.

Location of Data Plate

The data plate is located on the right side panel.

Immediately Inspect For Shipping Damage

All containers should be examined for damage before and during unloading. The freight carrier has assumed responsibility for its safe transit and delivery. If equipment is received damaged, either apparent or concealed, a claim must be made with the delivering carrier.

- A) Apparent damage or loss must be noted on the freight bill at the time of delivery. It must then be signed by the carrier representative (Driver). If this is not done, the carrier may refuse the claim. The carrier can supply the necessary forms.
- B) Concealed damage or loss if not apparent until after equipment is uncrated, a request for inspection must be made to the carrier within 15 days. The carrier should arrange an inspection. Be certain to hold all contents and packaging material.

Installation and start-up should be performed by a qualified installer who thoroughly read, understands and follows these instruction.

If you have questions concerning the installation, operation, maintenance or service of this product, write Technical Service Department Bakers Pride Oven Co., LLC, 1307 N. Watters Rd #180, Allen, TX 75013.

SAFETY PRECAUTIONS

DANGER

This symbol warns of imminent hazard which will result in serious injury or death.

WARNING

This symbol refers to a potential hazard or unsafe practice, which could result in serious injury or death.

CAUTION

This symbol refers to a potential hazard or unsafe practice, which may result in or moderate injury or product or property damage.

NOTICE

This symbol refers to information that needs special attention or must be fully understood even though not dangerous.

NOTICE

This product is intended for commercial use only. Not for household use.

CAUTION

These models are designed, built, and sold for commercial use. If these models are positioned so the general public can use the equipment make sure that cautions, warnings, and operating instructions are clearly posted near each unit so that anyone using the equipment will use it correctly and not injure themselves or harm the equipment.

WARNING

Improper installation, operation, service or maintenance can cause property damage, injury or death. Read and understand these instructions thoroughly before positioning, installing, maintaining or servicing this equipment



SAFETY PRECAUTIONS

⚠ WARNING

Keep the appliance free & clear of all combustible substances. If gas odor is detected at any time, immediately shut unit down at the main shutoff valve. Do not permit any open flames in the area of the appliance. Immediately contact an authorized Service Agency or your local Gas Supplier for service.

⚠ WARNING

Do not obstruct either the air inlet (underneath unit) or the ventilation air (back of unit). Provisions must be provided to provide an adequate air supply to the griddle.

NOTICE

Local codes regarding installation vary greatly from one area to another. The National Fire Protection Association, Inc., states in its NFPA96 latest edition that local codes are “Authority Having Jurisdiction” when it comes to requirement for installation of equipment. Therefore, installation should comply with all local codes.

GENERAL INSTALLATION INSTRUCTIONS

Ensure gas supply and gas type, as shown on unit nameplate, agree.

Unit installation must conform to the National Fuel Gas Code, ANSI Z223.1/NFPA 54, the National Gas Installation Code, CSA-B149.1, or the Propane Installation Code, CSA-B149.2 as applicable and in accordance with local codes.

Screw legs into the permanently fastened nuts on the four corners of the unit and tighten by hand. Level the unit by turning the adjustment screw at the bottom of each leg. Do not slide unit with legs mounted, lift if necessary to move unit.

Pipe threading compound must be resistant to the action of liquefied petroleum gases.

⚠ CAUTION

DO NOT use an open flame to check for leaks. Check all gas piping for leaks with a soap and water solution before operating unit.

THESE UNITS ARE SUITABLE FOR INSTALLATION ON NON-COMBUSTIBLE SURFACES ONLY.

Noncombustible clearances:

0” sides (0 mm) 0” rear (0 mm) 4” floor (102mm)

Do not obstruct the flow of combustion and ventilation air, under the unit by the legs or behind the unit by the flue.

Adequate clearance for air openings into the combustion chamber is required. Do not place objects between the bottom of the unit and the counter top.

There must be adequate clearance for removal of the front panel. All major parts except the burners are removable thru the front if the gas line is disconnected.

Unit must have adequate clearances for servicing. (Sides = 0”, Rear = 0”, Floor = 4”).

European Community Installation Instructions:

“THIS APPLIANCE MUST BE FITTED BY A COMPETENT PERSON. IN THE UK, CORGI REGISTERED INSTALLERS (INCLUDING THE REGIONS OF BRITISH GAS) UNDERTAKE TO WORK TO SAFE AND SATISFACTORY STANDARDS. THIS APPLIANCE MUST BE INSTALLED IN ACCORDANCE WITH THE GAS SAFETY (INSTALLATION AND USE) REGULATIONS AND THE RELEVANT BUILDING REGULATIONS / IEE. REGULATIONS. DETAILED RECOMMENDATIONS ARE CONTAINED IN THE FOLLOWING BRITISH STANDARD CODES OF PRACTICE - BS 6172, BS 5440 PART 2, BS 6891”

“THIS APPLIANCE MUST BE INSTALLED IN ACCORDANCE WITH THE RULES IN FORCE”

“MUST BE INSTALLED IN A WELL VENTILATED AREA. Ventilation requirements ie. B.S. 5440.”



MANUAL HEAVY DUTY GAS GRIDDLE OPERATION MANUAL

SPECIFICATIONS AND DIMENSIONS

| Model | Width In. (mm) | Depth In. (mm) | Height In. (mm) | Number of Burners | Btu/kw Per Burner | Total Btu/kw Hour | W.C In. ('Mbar') |
|-------------|-------------------|-------------------|--------------------|----------------------|----------------------|----------------------|---------------------|
| BPHMG-2424i | 24" (609.6) | 33.312" (846) | 15.437" (392.1) | 2 | 32,000 (9.78) | 64,000 (18.8) | 5 (12.4) |
| BPHMG-2436i | 36" (914.4) | 33.312" (846) | 15.437" (392.1) | 3 | 32,000 (9.78) | 96,000 (28.1) | 5 (12.4) |
| BPHMG-2448i | 48" (1219.2) | 33.312" (846) | 15.437" (392.1) | 4 | 32,000 (9.78) | 128,000 (37.5) | 5 (12.4) |
| BPHMG-2460i | 60" (1524.0) | 33.312" (846) | 15.437" (392.1) | 5 | 32,000 (9.78) | 160,000 (46.9) | 5 (12.4) |
| BPHMG-2472i | 72" (1828.8) | 33.312" (846) | 15.437" (392.1) | 6 | 32,000 (9.78) | 192,000 (56.3) | 5 (12.4) |

Griddle Surface Dimensions

| Model | Width In. (mm) | Depth In. (mm) |
|-------------|-------------------|-------------------|
| BPHMG-2424i | 23.844" (605.6) | 24" (609.6) |
| BPHMG-2436i | 35.844" (910.4) | 24" (609.6) |
| BPHMG-2448i | 47.844" (1215.2) | 24" (609.6) |
| BPHMG-2460i | 59.844" (1520.0) | 24" (609.6) |
| BPHMG-2472i | 71.844" (1824.8) | 24" (609.6) |

HEAVY DUTY GAS GRIDDLE: BPHMG-2424I

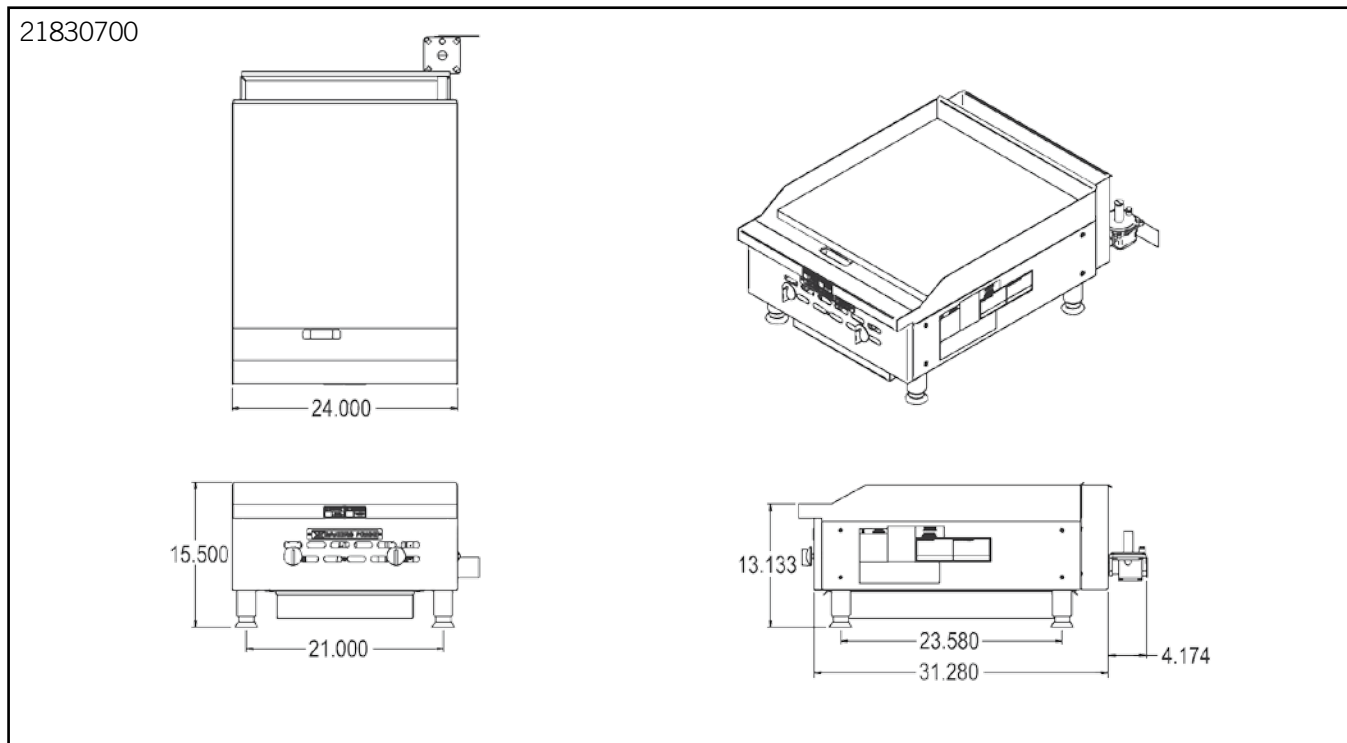



MANUAL HEAVY DUTY GAS GRIDDLE OPERATION MANUAL

HEAVY DUTY GAS GRIDDLE: BPHMG-2436I

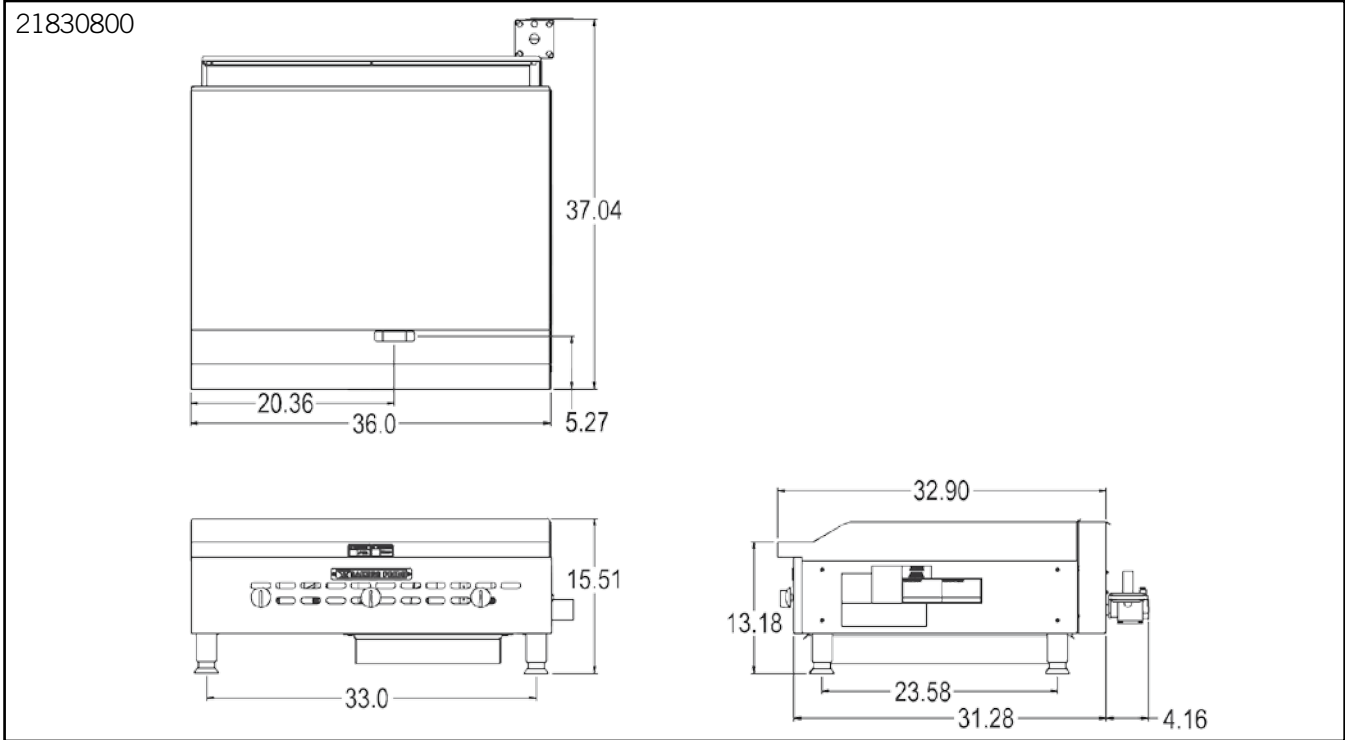

HEAVY DUTY GAS GRIDDLE: BPHMG-2448I

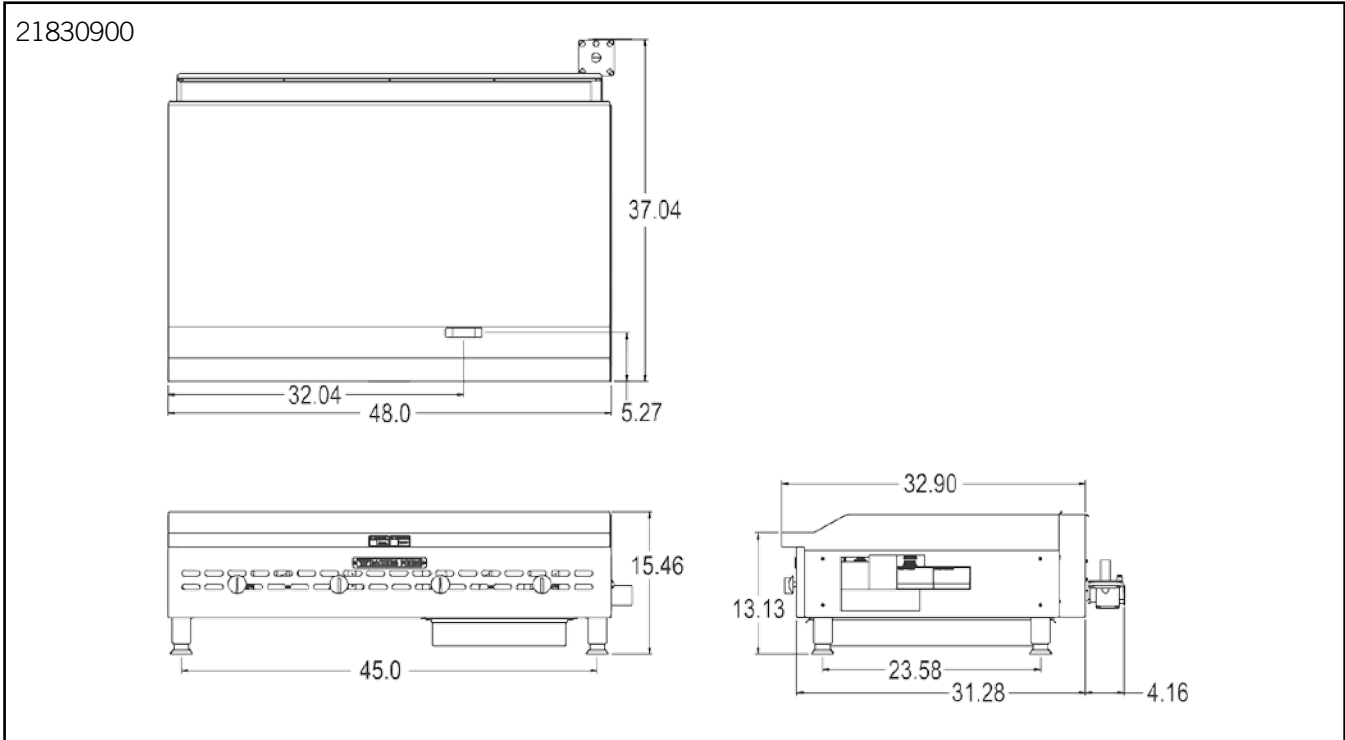



MANUAL HEAVY DUTY GAS GRIDDLE OPERATION MANUAL

HEAVY DUTY GAS GRIDDLE: BPHMG-2460I

21831000

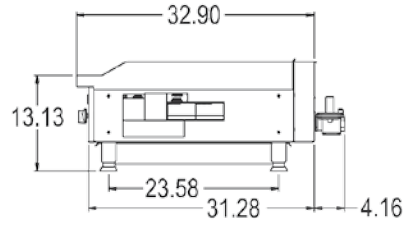
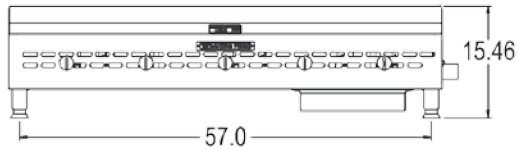
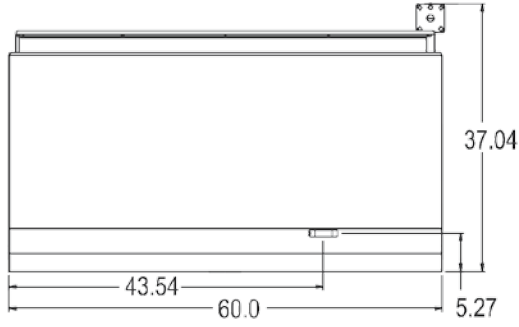

HEAVY DUTY GAS GRIDDLE: BPHMG-2472I

21831100

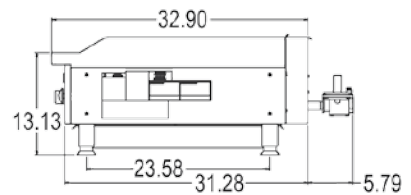
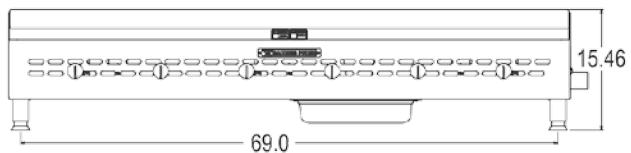
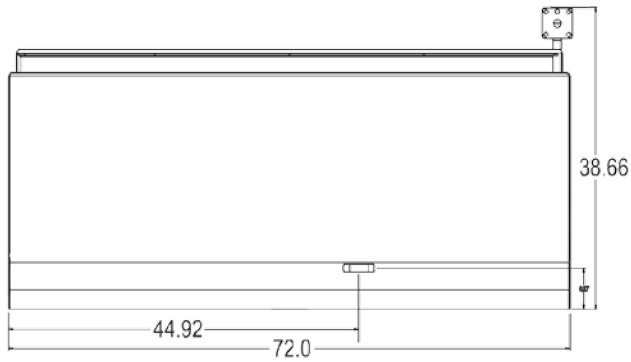

CONVERSION

- Instructions are for conversion from Natural Gas to Propane (L.P.) on all models HDTG.
- The conversion should be done before connecting the unit to the gas supply.
- Units are shipped from the factory equipped for use on natural gas. Orifices necessary for LP (propane) are provided in a bag tied to the valve on the front panel.
 1. Remove the knobs and front panel.
 2. Remove the orifice fittings from the valve. Change the orifices to the size recommended for propane (L.P.).
 3. Replace the orifice fittings into the valve.
- To change the regulator:

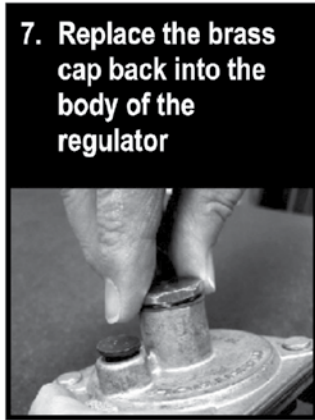

- Connect the regulator to the unit, connect gas and check for leaks.

⚠ WARNING
Do not use an open flame to check for leaks.

- Check the system pressure. With the front panel removed remove the plug from the manifold.
- Place a fitting in the plug opening and connect a manometer.

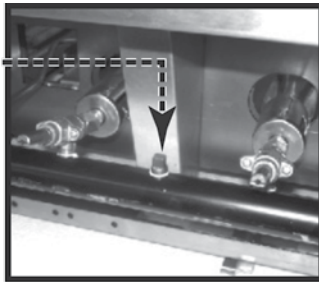

- For Natural gas the pressure in the manifold should be 5" water column or 12.4 millibar. For LP the pressure in the manifold should be 10" water Column of 24.9 millibar.



CONVERSION

- To adjust the pressure remove the brass cap and turn the white plastic part inside the stem of the regulator. See picture regulator 7.
- Take a wide straight screw driver and place it in the two notches shown in picture regulator 7 turn clockwise to increase pressure and counter-clockwise to reduce pressure. See picture regulator 7.
- Once the pressure has been adjusted replace the brass cap.

NOTICE

Note the blue cap on the regulator, this is the vent there are openings below the top rim. NEVER block these openings your regulator will fail to operate correctly. On at least a monthly basis blow off any dust or grease which may accumulate around this cap. The openings must remain open for the regulator to function. Clean more often in a very greasy atmosphere.

LIGHTING INSTRUCTIONS

HDMG Griddles are furnished with either a pilot safety valve or a standing pilot (not available in the European Community). Please follow the instructions for your unit. HMG Griddles are furnished with either a flame failure pilot or a standing pilot (not available in the European community).

Pilot Operation HMG Flame Failure Gas Valve:

Operation of the gas valve pilot:

1. Turn knob on the main gas valve to the pilot position
2. Depress knob to start gas flow to the pilot valve
3. Light pilot valve
 - a. Using a match or taper
4. Hold in knob for 15 to 30 seconds to heat up the thermocouple
5. Release knob and turn to the desired gas flow position
 - a. If pilot goes out repeat steps 1-4, some thermocouples will take longer to heat up

Standing Pilot Lighting Instructions: (Not Available in the European Community)

The pilot lights on the broilers have been set at the factory. A screwdriver may be required for the first lighting to adjust the flame for your elevation.

1. Turn off the manual shut off valve and wait 5 minutes to clear the gas.

2. Turn all knobs to the "OFF" position.
3. The valve can be accessed through an opening in the front panel or remove the cooking grates and light the pilot from above.
4. Turn the manual shut off valve on.
5. Hold an ignition source (match) to both openings on the pilot tube. When the flames are established, remove the ignition source.
6. Turn the burner knobs to "HI". If the burner does not ignite, promptly open the pilot valve more. If the pilot flame appears larger than necessary, turn it down and reset burner ignition. The pilot flame should be as small as possible but large enough to guarantee reliable ignition of the burners when the knobs are turned to "HI".

Relighting Pilot

If the pilot light should go out for any reason:

- Promptly shut off all gas at the manual shut off valve.
- Turn off all knobs and pilot valves; wait 5 minutes to clear gas.
- Relight following steps 4 through 6 under Standing Pilot Lighting Instructions.



LIGHTING INSTRUCTIONS

HDTG LIGHTING THE MAIN BURNER:

Since the burner is lit from constantly burning pilot, turn knobs to “HI” to put the unit in operation; then adjust to any desired position between “LO” and “HI”.

- To light burner, turn knob to “max.” then back off to the desired flame level. The range of adjustment is virtually infinite between high and off. (At the small flame, there is a pre-set low).
- When the broiler is first heated, it will smoke until oil used in manufacturing, preservation and dust from storage and shipping are burned off. An hour at “max.” on all burners is usually sufficient.
- Turn knobs off and let cool.
- For first cooking, set the grates at maximum tilt position and preheat before broiling. You will have to experiment with knob settings and grate position for each particular item.
- Clean regularly. Grates may be removed for washing in the sink. Brush out carbonized particles. Thoroughly wash the grease/water pan.

European Community:

If adjustment becomes necessary in the field, it should be done by a factory authorized and trained technician who should seal the screw after the adjustment to safeguard against un-authorized tampering by the end user.

All burners are lit from constantly burning pilots. Turning the valve to the desired flame height is all that is required to put the unit in service.

Do not permit fans to blow directly at the unit. Wherever possible, avoid open windows next to the units’ sides or back. Avoid wall type fans which create air cross-currents within a room.

It is also necessary that sufficient air should be allowed to enter the room to compensate for the amount of air removed by any ventilating system. Otherwise, a subnormal atmospheric pressure will occur, affecting operation and causing undesirable working conditions.

A properly designed and installed hood will act as the heart of the ventilating system for the room or area in which the unit is installed, and will leave the unit independent of changing draft conditions.

All valves must be checked and lubricated periodically. This must be done by an authorized service representative in your area.



OPERATING INSTRUCTIONS

Season Griddle:

Heat to low temperature (300 - 350 F/150-180C) and pour on a small amount of cooking oil, about one ounce (30cc) per square foot of surface. Spread the oil over the entire griddle surface with a cloth to create a thin film. Wipe off any excess oil with a cloth. Repeat this procedure 2 to 3 times until the griddle has a slick, mirror-like surface.

Operation

Turn the burners on about 15-20 minutes before cooking for preheating. Set the knobs to the desired flame height (HMG). Each valve will control the gas flow to the burner to bring that area of the plate up to the set temperature. If different temperature settings are to be used, adjoining areas should be set at progressively higher temperatures using the lowest temperatures on the outside burners. A uniform and systematic approach to the loading of the griddle will produce the most consistent product results.

CAUTION

Do not turn on gas valves without lighting the pilots. This could cause a build up of gas and potential explosion. be a little more flare ups in this position.

NOTICE

Due to heat transfer thru the griddle plate, adjoining zones can be no more than 25° different.

CLEANING / MAINTENANCE

Initial Cleaning:

Prior to operating your new griddle, thoroughly wash the griddle surface and the exterior with a mild detergent or soap solution. Do not use abrasive cleaners since this might damage the cabinet finish. If the stainless steel surfaces become discolored, scrub by rubbing only in the direction of the finished grain.

Cleaning:

1. Always turn unit off and allow it to cool completely before cleaning. Clean thoroughly before first use.
2. After each use, clean the griddle with wire brush or flexible spatula.
3. Once a day, thoroughly clean splash back, sides and front. Remove the grease drawer, empty it and wash it out.
4. Once a week, clean the griddle surface thoroughly. If necessary, use a griddle stone, wire brush or steel wool on the surface. Rub with the grain of the metal while the griddle is still warm. A detergent may be used on the plate surface to help clean it; but, care must be taken to be sure the detergent is thoroughly removed. After removal of the detergent, the surface

of the plate should then be covered with a thin film of oil to prevent rusting. Clean stainless surfaces with a damp cloth and polish with a soft dry cloth. To remove discoloration, use a nonabrasive cleaner. After each “weekly” cleaning, the griddle must be seasoned again. If the griddle usage is very high, the “weekly” cleaning procedures may be done more often than once a week.

Extended Shutdown:

Turn the manual shutoff valve to “OFF”; (field installed valve not supplied by the manufacturer); turn all control knobs to the “OFF” position; and shut off the pilot flame by turning the adjustment on the pilot valve.

NOTICE

Gas shutoff valve is supplied by the manufacturer on CE or European Community models.

If the griddle is to be shut down for an extended period, put a heavy coat of grease over the griddle plate.



MANUAL HEAVY DUTY GAS GRIDDLE OPERATION MANUAL

SERVICE / REPAIR

NOTICE

This appliance must only be serviced by an authorized agent.

NOTICE

Parts protected by the manufacturer or his agent are not to be adjusted by the installer, unless the installer is an authorized service agent.

TROUBLESHOOTING GUIDE

| PROBLEM | POSSIBLE CAUSE |
|---|---|
| Heat does not come on when thermostat is turned on. | Thermostat is bad. |
| | Pilot burner not lit. |
| | Gas valve is bad. |
| Pilot burner will not light. | Obstructed pilot orifice. |
| | Pilot gas turned off at automatic pilot. |
| | Automatic pilot valve is bad. |
| Pilot burner will not stay lit. | Thermocouple is bad. |
| | Thermocouple is not hot enough. |
| | Obstructed or wrong size pilot orifice. |
| | Gas supply is not purged of air. |
| | Air is blowing pilot light out. |
| Fat appears to smoke excessively. | Automatic pilot valve is bad. |
| | Heat is set too high. |
| Food sticks to griddle. | Moisture in the food may be turning into steam. |
| | Heat is set too high. |
| | Griddle surface needs cleaning and/or seasoning. |
| Food burned around edges or contains dark specks. | Surface under food may not have been covered with enough cooking oil. |
| | Heat is set too high. |
| | Griddle surface needs cleaning and/or seasoning. |
| Food is undercooked inside. | Surface under food may not have been covered with enough cooking oil. |
| | Heat is set too high. |
| | Food may not have been cooked for long enough time. |
| Food tastes greasy or has objectionable off-flavor. | Food itself may have off flavor. |
| | Food may have been stored improperly before cooking. |
| | Too much griddle fat used. |
| | Heat is set too low. |
| Noticeable build-up of gum on griddle. | Heat is set too high |
| | Griddle surface needs cleaning and/or seasoning. |
| | Too much griddle fat used. |



MANUAL HEAVY DUTY GAS GRIDDLE OPERATION MANUAL

EXPLODED VIEW – BPHMG GRIDDLES (DOMESTIC)

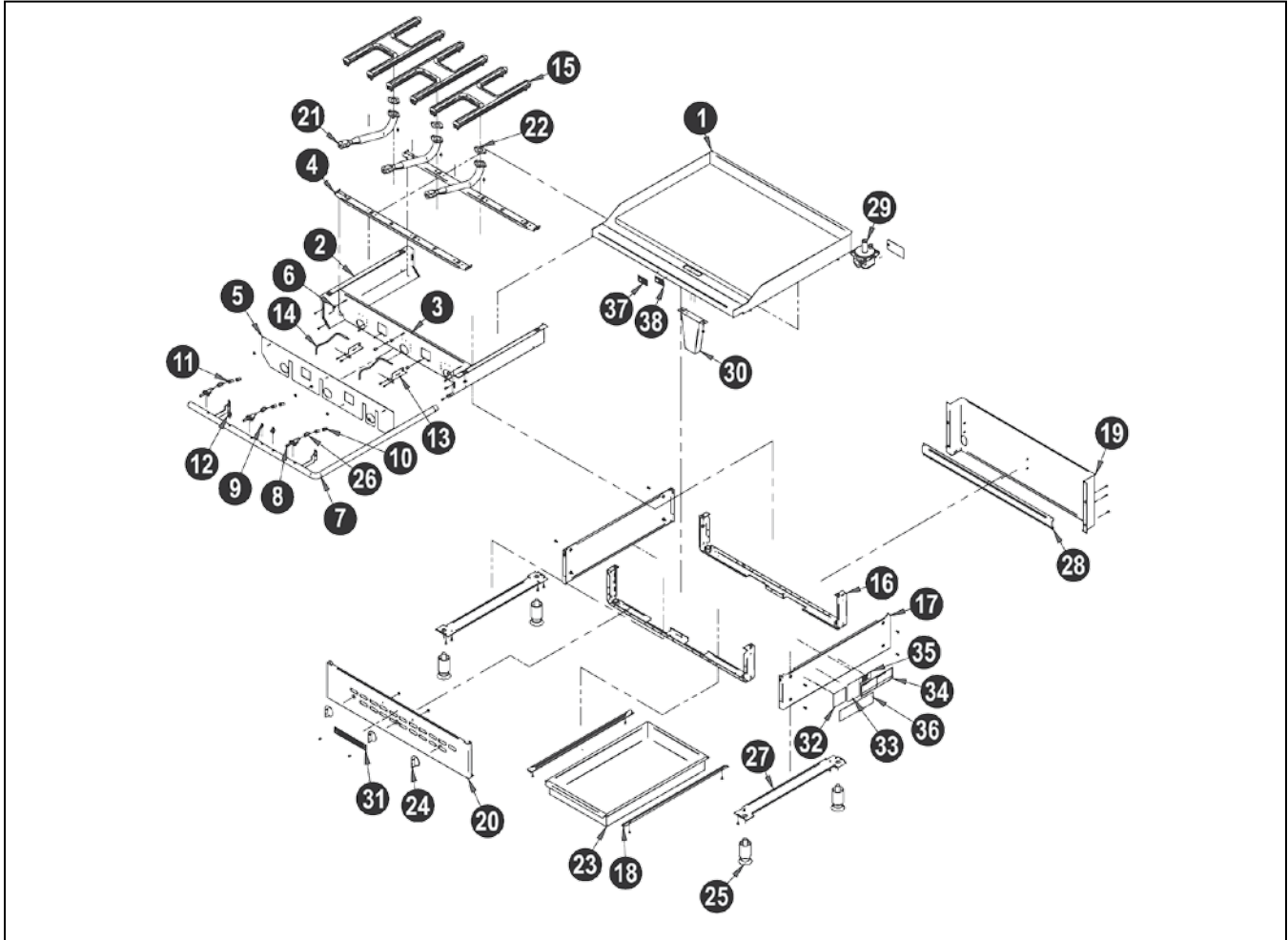

PARTS LIST – BPHMG GRIDDLES (DOMESTIC)

| Item | P/N | Description | BPHMG-2424i | BPHMG-2436i | BPHMG-2448i | BPHMG-2460i | BPHMG-2472i |
|------|----------|------------------------|-------------|-------------|-------------|-------------|-------------|
| 1 | 21830720 | Weldm't, Griddle Plate | 1 | | | | |
| | 21830820 | Weldm't, Griddle Plate | | 1 | | | |
| | 21830920 | Weldm't, Griddle Plate | | | 1 | | |
| | 21831020 | Weldm't, Griddle Plate | | | | 1 | |
| | 21831120 | Weldm't, Griddle Plate | | | | | 1 |
| 2 | 21826433 | Side, Firebox | 2 | 2 | 2 | 2 | 2 |
| 3 | 21826022 | Body, 24" Firebox | 1 | | | | |
| | 21826122 | Body, 36" Firebox | | 1 | | | |
| | 21826222 | Body, 48" Firebox | | | 1 | | |
| | 21826322 | Body, 60" Firebox | | | | 1 | |
| | 21826422 | Body, 72" Firebox | | | | | 1 |
| 4 | 21826017 | Support, Burner | 2 | | | | |
| | 21826117 | Support, Burner | | 2 | | | |
| | 21826217 | Support, Burner | | | 2 | | |
| | 21826317 | Support, Burner | | | | 2 | |
| | 21826427 | Support, Burner | | | | | 2 |



MANUAL HEAVY DUTY GAS GRIDDLE OPERATION MANUAL

PARTS LIST – BPHMG GRIDDLES (DOMESTIC)

| Item | P/N | Description | BPHMG-2424i | BPHMG-2436i | BPHMG-2448i | BPHMG-2460i | BPHMG-2472i |
|------|----------|-----------------------------------|-------------|-------------|-------------|-------------|-------------|
| 5 | 21826027 | Baffle, Front Heat | 1 | | | | |
| | 21826127 | Baffle, Front Heat | | 1 | | | |
| | 21826227 | Baffle, Front Heat | | | 1 | | |
| | 21826327 | Baffle, Front Heat | | | | 1 | |
| | 21826427 | Baffle, Front Heat | | | | | 1 |
| 6 | 21813085 | Spacer | 4 | 4 | 5 | 5 | 6 |
| 7 | 21830725 | Manifold, 24" | 1 | | | | |
| | 21830825 | Manifold, 36" | | 1 | | | |
| | 21830925 | Manifold, 48" | | | 1 | | |
| | 21831025 | Manifold, 60" | | | | 1 | |
| | 21831125 | Manifold, 72" | | | | | 1 |
| 8 | 2068500 | Valve, Gas 210° On/Off | 2 | 3 | 4 | 5 | 6 |
| 9 | 2092517 | Plug, 1/8 NPTM | 1 | 1 | 1 | 1 | 1 |
| 10 | 2066834 | Hood, Orifice #34 | 2 | 3 | 4 | 5 | 6 |
| 11 | 2066851 | Hood, Orifice #51 | 2 | 3 | 4 | 5 | 6 |
| 12 | 2068002 | Valve, Pilot 90° | 1 | 2 | 2 | 3 | 3 |
| 13 | 21825113 | Bracket, Pilot | 1 | 2 | 2 | 3 | 3 |
| 14 | 21830712 | Bumer, Pilot | 1 | 2 | 2 | 3 | 3 |
| 15 | 2065846 | Bumer Cast H | 2 | 3 | 4 | 5 | 6 |
| 16 | 22400010 | Support, Leg 24" | 2 | | | | |
| | 22400015 | Support, Leg 36" | | 2 | | | |
| | 22400020 | Support, Leg 48" | | | 2 | | |
| | 22400025 | Support, Leg 60" | | | | 2 | |
| | 22400030 | Support, Leg 72" | | | | | 2 |
| 17 | 21826053 | Panel, Right & Left Side | 2 | 2 | 2 | 2 | 2 |
| 18 | 21825011 | Guide, Grease Slide | 2 | 2 | 2 | 2 | 2 |
| 19 | 21826052 | Panel, Back 24" | 1 | | | | |
| | 21826652 | Panel, Back 36" | | 1 | | | |
| | 21826252 | Panel, Back 48" | | | 1 | | |
| | 21826332 | Panel, Back 60" | | | | 1 | |
| | 21826452 | Panel, Back 72" | | | | | 1 |
| 20 | 21830719 | Panel, Control 24" | 1 | | | | |
| | 21830819 | Panel, Control 36" | | 1 | | | |
| | 21830919 | Panel, Control 48" | | | 1 | | |
| | 21831019 | Panel, Control 60" | | | | 1 | |
| | 21831119 | Panel, Control 72" | | | | | 1 |
| 21 | 2065849 | Venturi, Hvy Dty BP Griddles | 2 | 3 | 4 | 5 | 6 |
| 22 | 2065916 | Gasket, Burner | 2 | 3 | 4 | 5 | 6 |
| 23 | 2425310 | Pan, Grease 24" | 1 | 1 | 1 | 1 | 1 |
| 24 | 8706400 | Knob, Metal Cookline .375 D Shaft | 2 | 3 | 4 | 5 | 6 |
| 25 | 8633700 | Leg, 2" Dia. Hvy Dty | 4 | 4 | 4 | 4 | 4 |
| 26 | 2065839 | Adapter, 15° Angle Elbow | 2 | 3 | 4 | 5 | 6 |
| 27 | 22400003 | Brace, Leg | 2 | 2 | 2 | 2 | 2 |
| 28 | 21826134 | Channel, Stiffener | NA | 1 | | | |
| | 21826234 | Channel, Stiffener | | | 1 | | |
| | 21826334 | Channel, Stiffener | | | | 1 | |
| | 21826434 | Channel, Stiffener | | | | | 1 |
| 29 | 2067600 | Regulator, 5" WC. & 10" WC. | 1 | 1 | 1 | 1 | 1 |
| 30 | 21825012 | Side, Grease Chute | 2 | 2 | 2 | 2 | 2 |
| 31 | 8808900 | Nameplate, 8" Bakers Pride | 1 | 1 | 1 | 1 | 1 |
| 32 | 8861000 | Label, Spec | 1 | 1 | 1 | 1 | 1 |
| 33 | 8809920 | Decal, Improper Installation | 1 | 1 | 1 | 1 | 1 |
| 34 | 8837134 | Label, Orifice Size | 1 | 1 | 1 | 1 | 1 |
| 35 | 8825300 | Decal, Leg | 1 | 1 | 1 | 1 | 1 |
| 36 | 8837130 | Decal, Operating Instructions | 1 | 1 | 1 | 1 | 1 |
| 37 | 43813103 | Label, Hot Surface | 1 | 1 | 1 | 1 | 1 |
| 38 | 43813149 | Label, Hot Surface (French) | 1 | 1 | 1 | 1 | 1 |
| 39 | 8835410 | Inst/Op Manual (N/S) | 1 | 1 | 1 | 1 | 1 |

EXPLODED VIEW – BPHMG GRIDDLES (CE)

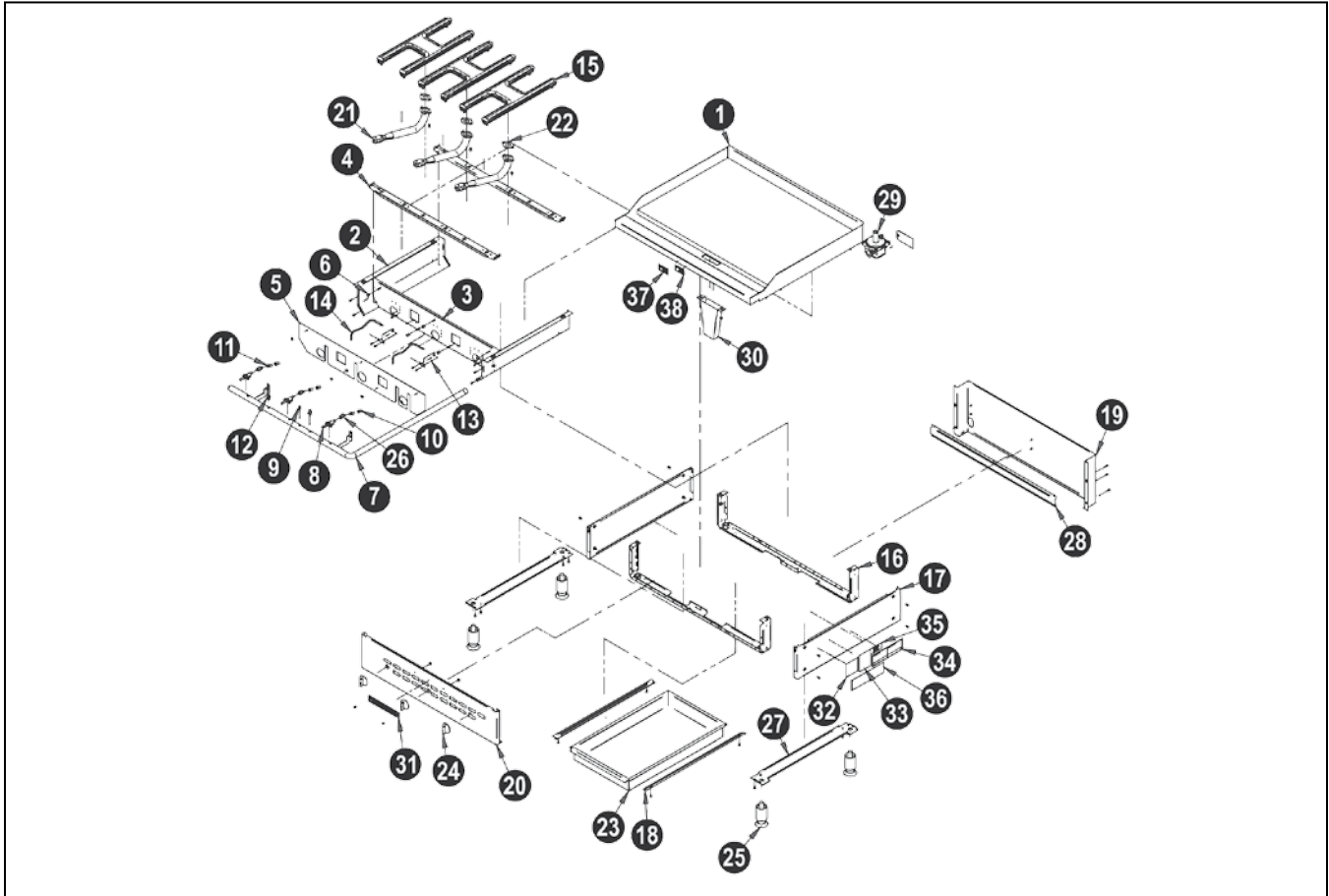

PARTS LIST – BPHMG GRIDDLES (CE)

| Item | P/N | Description | BPHMG-2424i | BPHMG-2436i | BPHMG-2448i | BPHMG-2460i | BPHMG-2472i |
|------|----------|------------------------|-------------|-------------|-------------|-------------|-------------|
| 1 | 21830720 | Weldm't, Griddle Plate | 1 | | | | |
| | 21830820 | Weldm't, Griddle Plate | | 1 | | | |
| | 21830920 | Weldm't, Griddle Plate | | | 1 | | |
| | 21831020 | Weldm't Griddle Plate | | | | 1 | |
| | 21831120 | Weldm't, Griddle Plate | | | | | 1 |
| 2 | 21826433 | Side, Firebox | 2 | 2 | 2 | 2 | 2 |
| 3 | 21826036 | Body, 24" Firebox | 1 | | | | |
| | 21826136 | Body, 36" Firebox | | 1 | | | |
| | 21826236 | Body, 48" Firebox | | | 1 | | |
| | 21826336 | Body, 60" Firebox | | | | 1 | |
| | 21826436 | Body, 72" Firebox | | | | | 1 |
| 4 | 21826017 | Support, Bumer | 2 | | | | |
| | 21826117 | Support, Bumer | | 2 | | | |
| | 21826217 | Support, Bumer | | | 2 | | |
| | 21826317 | Support, Bumer | | | | 2 | |
| | 21826417 | Support, Bumer | | | | | 2 |
| 5 | 21826037 | Baffle, Front Heat | 1 | | | | |
| | 21826137 | Baffle, Front Heat | | 1 | | | |
| | 21826237 | Baffle, Front Heat | | | 1 | | |
| | 21826337 | Baffle, Front Heat | | | | 1 | |
| | 21826437 | Baffle, Front Heat | | | | | 1 |
| 6 | 21813085 | Spacer | 4 | 4 | 5 | 5 | 6 |



MANUAL HEAVY DUTY GAS GRIDDLE OPERATION MANUAL

PARTS LIST – BPHMG GRIDDLES (CE)

| Item | P/N | Description | BPHMG-2424i | BPHMG-2436i | BPHMG-2448i | BPHMG-2460i | BPHMG-2472i |
|------|----------|-------------------------------------|-------------|-------------|-------------|-------------|-------------|
| 7 | 21830735 | Manifold, 24" | 1 | | | | |
| | 21830835 | Manifold, 36" | | 1 | | | |
| | 21830935 | Manifold, 48" | | | 1 | | |
| | 21831035 | Manifold, 60" | | | | 1 | |
| | 21831135 | Manifold, 72" | | | | | 1 |
| 8 | 2068300 | Valve, Gas 210° On/Off | 2 | 3 | 4 | 5 | 6 |
| 9 | 2092517 | Plug, 1/8 NPTM | 1 | 1 | 1 | 1 | 1 |
| 10 | 2066834 | Hood, Orifice #34 | 2 | 3 | 4 | 5 | 6 |
| 11 | 2066851 | Hood, Orifice #51 | 2 | 3 | 4 | 5 | 6 |
| 12 | 1473700 | Thermocouple, CE Valve 600mm | 2 | 3 | 4 | 5 | 6 |
| 13 | 21826413 | Bracket, Pilot | 2 | 3 | 4 | 5 | 6 |
| 14 | 20932100 | Burner, Pilot | 2 | 3 | 4 | 5 | 6 |
| 15 | 2065846 | Burner, Cast H | 2 | 3 | 4 | 5 | 6 |
| 16 | 22400010 | Support, Leg 24" | 2 | | | | |
| | 22400015 | Support, Leg 36" | | 2 | | | |
| | 22400020 | Support, Leg 48" | | | 2 | | |
| | 22400025 | Support, Leg 60" | | | | 2 | |
| | 22400030 | Support, Leg 72" | | | | | 2 |
| 17 | 21826053 | Panel, Right & Left Side | 2 | 2 | 2 | 2 | 2 |
| 18 | 21825011 | Guide, Grease Slide | 2 | 2 | 2 | 2 | 2 |
| 19 | 21826052 | Panel, Back 24" | 1 | | | | |
| | 21826652 | Panel, Back 36" | | 1 | | | |
| | 21826252 | Panel, Back 48" | | | 1 | | |
| | 21826332 | Panel, Back 60" | | | | 1 | |
| | 21826452 | Panel, Back 72" | | | | | 1 |
| 20 | 21830741 | Panel, Control 24" CE | 1 | | | | |
| | 21830841 | Panel, Control 36" CE | | 1 | | | |
| | 21830941 | Panel, Control 48" CE | | | 1 | | |
| | 21831041 | Panel, Control 60" CE | | | | 1 | |
| | 21831141 | Panel, Control 72" CE | | | | | 1 |
| 21 | 2065849 | Venturi, Hvy Dty BP Griddles | 2 | 3 | 4 | 5 | 6 |
| 22 | 2065916 | Gasket, Burner | 2 | 3 | 4 | 5 | 6 |
| 23 | 2425310 | Pan Grease 24" | 1 | 1 | 1 | 1 | 1 |
| 24 | 8706400 | Knob, Metal Cookline .375 D Shaft | 2 | 3 | 4 | 5 | 6 |
| 25 | 8633700 | Leg, 2" Dia. Hvy Dty | 4 | 4 | 4 | 4 | 4 |
| 26 | 2065839 | Adapter, 15° Angle Elbow | 2 | 3 | 4 | 5 | 6 |
| 27 | 22400003 | Brace, Leg | 2 | 2 | 2 | 2 | 2 |
| 28 | 21826134 | Channel, Stiffener | NA | 1 | | | |
| | 21826234 | Channel, Stiffener | | | 1 | | |
| | 21826334 | Channel, Stiffener | | | | 1 | |
| | 21826434 | Channel, Stiffener | | | | | 1 |
| 29 | 2067600 | Regulator, 5" W.C. & 10" W.C. | 1 | 1 | 1 | 1 | 1 |
| 30 | 21825012 | Side, Grease Chute | 2 | 2 | 2 | 2 | 2 |
| 31 | 8808900 | Nameplate, 8" Bakers Pride | 1 | 1 | 1 | 1 | 1 |
| 32 | 8861000 | Label, Spec | 1 | 1 | 1 | 1 | 1 |
| 33 | 8809920 | Decal, Improper Installation | 1 | 1 | 1 | 1 | 1 |
| 34 | 8837134 | Label, Orifice Size | 1 | 1 | 1 | 1 | 1 |
| 35 | 8825300 | Decal, Leg | 1 | 1 | 1 | 1 | 1 |
| 36 | 8837130 | Decal, Operating Instructions | 1 | 1 | 1 | 1 | 1 |
| 37 | 43813103 | Label, Hot Surface | 1 | 1 | 1 | 1 | 1 |
| 38 | 43813149 | Label, Hot Surface (French) | 1 | 1 | 1 | 1 | 1 |
| 39 | 8835410 | Lnst/Op Manual (N/S) | 1 | 1 | 1 | 1 | 1 |
| 40 | 2065884 | Ignitor | 2 | 3 | 4 | 5 | 6 |
| 41 | 2065885 | Electrode, Spark | 2 | 3 | 4 | 5 | 6 |
| 42 | 2069700 | Valve, Ball 3/4" 90° | 1 | 1 | 1 | 1 | 1 |
| 43 | 2092612 | Elbow, Brass 3/8-27f x 3/8 C | 2 | 3 | 4 | 5 | 6 |
| 44 | 2092614 | Elbow, Brass 3/8c x 3/8-27m Brass | 2 | 3 | 4 | 5 | 6 |
| 45 | 2092626 | Pipe, Inlet | 1 | 1 | 1 | 1 | 1 |
| 46 | 20932101 | Nut, Compression & Ferrule | 2 | 3 | 4 | 5 | 6 |
| 47 | 21826016 | Bracket, Thermocouple | 2 | 3 | 4 | 5 | 6 |
| 48 | 21830817 | Tube, Pilot Supply CE | 2 | 3 | 4 | 5 | 6 |
| 49 | 21830847 | Tube, Orifice Supply | 2 | 3 | 4 | 5 | 6 |
| 50 | 8806070 | Label, Delivery CE Gas Units (N/S) | 1 | 1 | 1 | 1 | 1 |
| 51 | 8806075 | Label, Packaging CE Gas Units (N/s) | 1 | 1 | 1 | 1 | 1 |
| 52 | 8806080 | Label, CE Ventilation (N/S) | 1 | 1 | 1 | 1 | 1 |



MANUAL HEAVY DUTY GAS GRIDDLE OPERATION MANUAL

BAKERS PRIDE LIMITED WARRANTY

| | |
|--------------------------|--|
| WHAT IS COVERED | <p>This warranty covers defects in material and workmanship under normal use, and applies only to the original purchaser providing that:</p> <ul style="list-style-type: none">• The equipment has not been accidentally or intentionally damaged, altered or misused;• The equipment is properly installed, adjusted, operated and maintained in accordance with National and local codes and in accordance with the installation instruction provided with the product;• The serial number rating plate affixed to the equipment has not been defaced or removed. |
| WHO IS COVERED | <p>This warranty is extended to the original purchaser and applies only to equipment purchased for use in the U.S.A.</p> |
| COVERAGE PERIOD | <p>Cyclone Convection Ovens: BCO Models: One (1) Year limited parts and labor; (1) Year limited door warranty. GDCO Models: Two (2) Year limited parts and labor; (2) Year limited door warranty. CO11 Models: Two (2) Year limited parts and labor; (5) Year limited door warranty. All Other Products: One (1) Year limited parts and labor. Warranty period begins the date of dealer invoice to customer or ninety (90) days after shipment date from Bakers Pride - whichever comes first.</p> |
| WARRANTY | <p>This warranty covers on-site labor, parts and reasonable travel time and travel expenses of the authorized service</p> |
| COVERAGE | <p>representative up to (100) miles, round trip, and (2) hours travel time. The purchaser, however, shall be responsible for all expenses related to travel, including time, mileage and shipping expenses on smaller counter models that may be carried into a Factory Authorized Service Center, including the following models: PX-14, PX-16, P18, P22S, P24S, PD-4, PDC, WS Series and BK-18.</p> |
| EXCEPTIONS | <p>All removable parts in Bakers Pride® cooking equipment, including but not limited to: Burners, Grates, Radiants, Stones and Valves, are covered for a period of SIX MONTHS. All Ceramic Baking Decks are covered for a period of THREE MONTHS. The installation of these replacement decks is the responsibility of the purchaser. The extended Cyclone door warranty years 3 through 5 is a parts only warranty and does not include labor, travel, milage or any other charges.</p> |
| EXCLUSIONS | <ul style="list-style-type: none">• Negligence or acts of God,• Failures caused by erratic voltages or gas supplies,• Thermostat calibrations after (30) days from equipment installation date,• Unauthorized repair by anyone other than a Bakers Pride Factory Authorized Service Center,• Air and Gas adjustments,• Damage in shipment,• Light bulbs,• Alteration, misuse or improper installation,• Glass doors and door adjustments,• Thermostats and safety valves with broken capillary tubes,• Fuses,• Char-broiler work decks and cutting boards,• Tightening of conveyor chains,• Adjustments to burner flames and cleaning of pilot burners,• Tightening of screws or fasteners.• Accessories — spatulas, forks, steak turners, grate lifters, oven brushes, scrapers, peels. etc.,• Freight — other than normal UPS charges,• Ordinary wear and tear. |
| INSTALLATION | <p>Leveling and installation of decks as well as proper installation and check out of all new equipment —per appropriate installation and use materials — is the responsibility of the dealer or installer, not the manufacturer.</p> |
| REPLACEMENT PARTS | <p>Bakers Pride genuine Factory OEM parts receive a (90) day materials warranty effective from the date of installation by a Bakers Pride Factory Authorized Service Center.</p> |

This Warranty is in lieu of all other warranties, expressed or implied, and all other obligations or liabilities on the manufacturer's part. Bakers Pride shall in no event be liable for any special, indirect or consequential damages, or in any event for damages in excess of the purchase price of the unit. The repair or replacement of proven defective parts shall constitute a fulfillment of all obligations under the terms of this warranty.

Standex

Food Service Equipment Group

The Standex Food Service Equipment Group (FSEG) is a manufacturer of innovative commercial food service equipment offering a wealth of refrigeration and cooking expertise. Products include walk-in coolers and freezers; hot and cold display cabinets, cases, and storage systems; commercial ovens, rotisseries, and cooking equipment; and rotary vane pumps.

Ask your sales representative about how the power of all Standex brands can work for you.
www.standex.com/segments/food-service

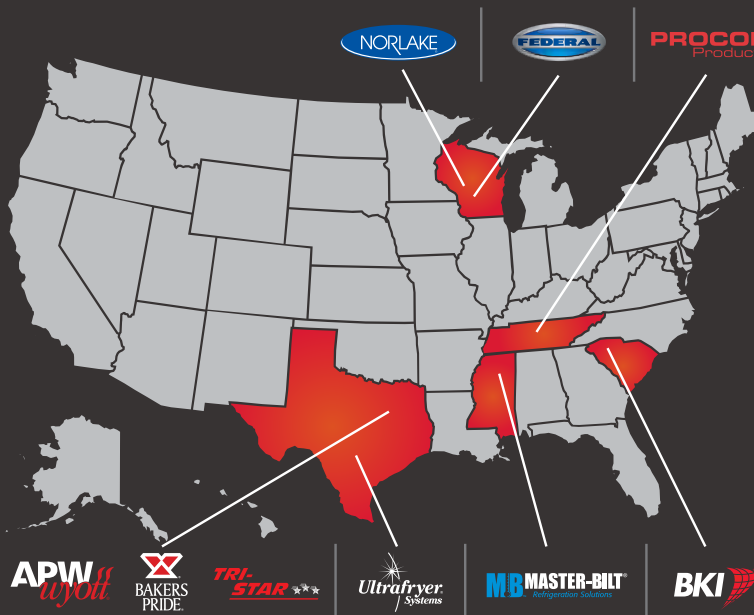

Be sure to keep up with new product announcements and events on social media!

