

BLODGETT[®]

BLODGETT[®]

BLODGETT[®]

BLODGETT[®]

BLODGETT[®]

BLODGETT[®]

BLODGETT[®]

BLODGETT[®]

BLODGETT[®]

BLODGETT[®]

BLODGETT[®]

BLODGETT[®]

BLG-G
GAS FLOOR MODEL BRAISING PAN WITH
MANUAL GEARBOX TILT
INSTALLATION – OPERATION – MAINTENANCE



BLODGETT OVEN COMPANY

www.blodgett.com

44 Lakeside Avenue, Burlington, Vermont 05401 USA Telephone: (802) 658-6600 Fax: (802) 864-0183

S00076 Rev A (8/04)

IMPORTANT NOTES FOR INSTALLATION AND OPERATION

It is recommended that this manual be read thoroughly and that all instructions be followed carefully. This manual should be retained for future reference.

	This is the safety alert symbol. It is used to alert you to potential personal injury hazards. Obey all safety messages that follow this symbol to avoid possible injury or death.
---	---

	FOR YOUR SAFETY: Do not store or use gasoline or other flammable vapors or liquids in the vicinity of this or any other appliance.
---	---

	WARNING: Improper installation, operation, adjustment, alteration, service or maintenance can cause property damage, injury or death. Read the installation, operating and maintenance instructions thoroughly before installing, operating or servicing this equipment.
---	---

PURCHASER: Instructions to be followed in the event that the operator of this appliance smells gas must be posted in a prominent location. This information shall be obtained by consulting the local gas supplier.

Keep the appliance area free and clear from combustibles.

Do not obstruct the flow of combustion and ventilation air.





Adequate clearances must be maintained for servicing and proper operation.

Contact the factory, the factory representative or a local service company to perform maintenance and repairs should the appliance malfunction. Refer to warranty terms.

TABLE OF CONTENTS

DESCRIPTION	PAGE
Important Notes for Installation and Operation	2
1.0 Service Connections	4
2.0 Installation Instructions	5
3.0 Operation Instructions	8
4.0 Periodic Maintenance	11
5.0 Cooking Guidelines	13
6.0 Troubleshooting.....	17

1.0 SERVICE CONNECTIONS

	Electrical connection to be as specified on data plat. Unit supplied with 6 foot cord with 3-prong plug.
	GAS CONNECTION: Supply gas through 3/4" pipe. A gas shut-off valve must be installed in supply piping convenient and adjacent to appliance.
	COLD WATER: 3/8" O.D. tubing to faucet. (OPTIONAL)
	HOT WATER: 3/8" O.D. tubing to faucet. (OPTIONAL)

MODEL	GAS SUPPLY		
	BTU/HR.	kW/HR.	SUPPLY PIPE PRESSURE (W.C.)
BLG-30G	100,000	29.3	Natural 7"-14" (178-356mm)
BLG-40G	125,000	36.5	

DIMENSIONS

MODEL	CAPACITY	UNITS	A	B	C	D	E	F
BLG-30G	30 gallons	inches	36.0	33.63	33.5	23.5	38.88	74.38
	114 litres	mm	914	854	851	597	987	1889
BLG-40G	40 gallons	inches	48.0	45.63	43.5	23.5	39.38	73.75
	152 litres	mm	1219	1159	1105	597	1000	1899

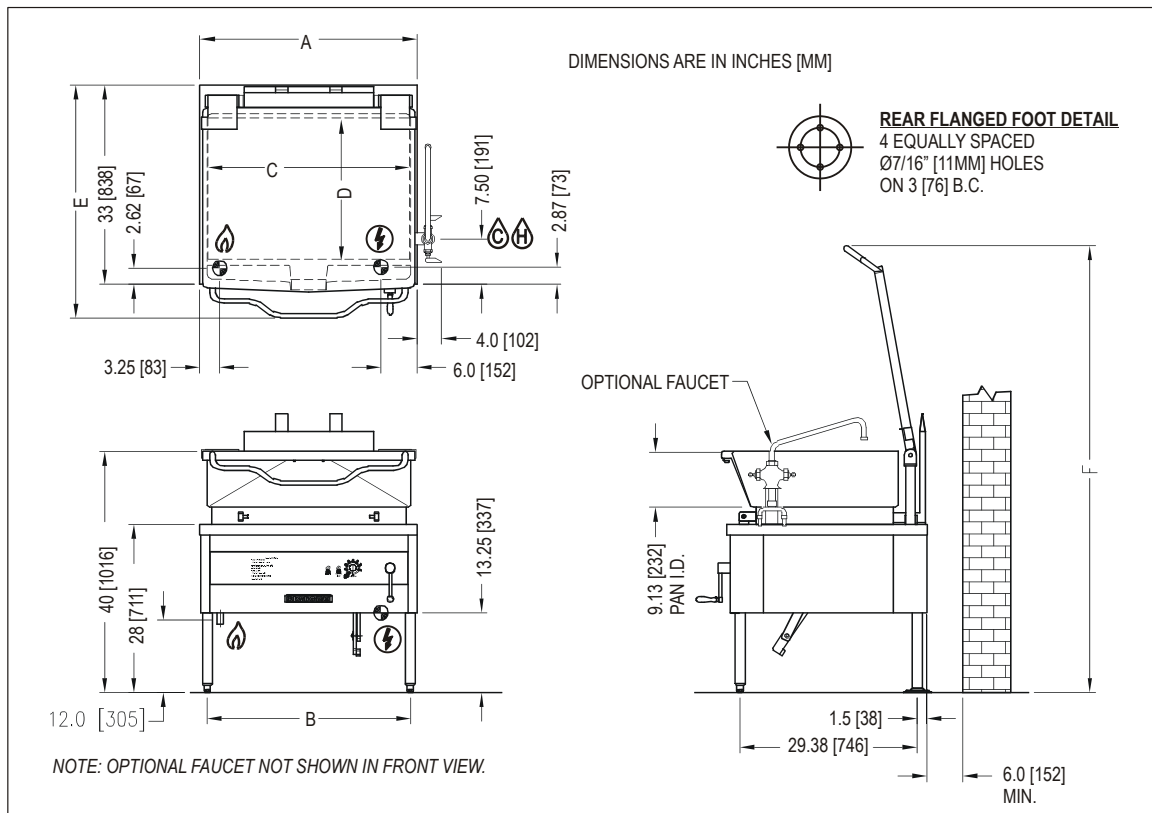

2.0 INSTALLATION INSTRUCTIONS

UNPACKING

Immediately after unpacking, check for possible shipping damage. If the tilting braising pan is found to be damaged, save the packaging material and contact the carrier within 15 days of delivery.

Before installing, verify that the type of gas supply (natural or propane) and electrical service agree with the specifications on the rating plate located on the left side panel as you face the front of the braising pan. If the supply and equipment requirements do not agree, contact your dealer or Blodgett.

LOCATION

The equipment must be kept free and clear of combustible substances. The tilting braising pan, when installed, must have minimum clearance from combustible and non-combustible construction of 3" (76 mm) from sides and 6" (152 mm) from the rear. The tilting braising pan is intended for use on non-combustible floors.

The installation location must allow adequate clearances for servicing and proper operation. A minimum front clearance of 36" (914 mm) is required.

The tilting braising pan must be installed so that the flow of combustion and ventilation air will not be obstructed. Adequate clearance for air openings into the combustion chamber must be provided. Make sure there is an adequate supply of air in the room suitable for the amount of combustion gas feeding the braising pan burners.

Do not permit fans to blow directly at the tilting braising pan, and wherever possible, avoid open windows next to the tilting braising pan. Avoid wall-type fans which create air cross currents within the room.

INSTALLATION CODES AND STANDARDS

Installation must conform with local codes, or in the absence of local codes, with the *National Fuel Gas Code, ANSI Z223.1/NFPA 54*, or the *Natural Gas and Propane Installation Code, CSA B149.1*, as applicable.

1. The appliance and its individual shut off valve must be disconnected from the gas supply piping system during any pressure testing of that system at pressures in excess of ½ psi (3.5 kPa).

2.0 INSTALLATION INSTRUCTIONS (Continued)

INSTALLATION CODES AND STANDARDS (Continued)

2. The appliance must be isolated from the gas supply piping system by closing its individual manual shut off valve during any pressure testing of the gas supply piping system at test pressures equal to or less than ½ psi (3.5 kPa).

Electrical grounding must be provided in accordance with local codes, or in the absence of local codes, with the National Electrical Code, ANSI/NFPA 70, or the Canadian Electrical Code, CSA C22.2, as applicable.

ANSI/NFPA 96 - (latest edition), "Standard for Ventilation and Fire Protection of Commercial Cooking Operations," available from the National Fire Protection Association, Batterymarch Park, Quincy, MA, USA, 02269.

FLUE CONNECTIONS

Do not obstruct the flow of flue gases from the flue duct located on the rear of the tilting braising pan. It is recommended that the flue gases be ventilated to the outside of the building through a ventilation system installed by qualified personnel.

	<p>WARNING: ELECTRICAL GROUNDING INSTRUCTIONS This appliance is equipped with a three-prong (grounding) plug for your protection against shock hazard and should be plugged directly into a properly grounded three-prong receptacle. Do not cut or remove the grounding prong from this plug. (120V units only).</p>
---	--

LEVELLING AND ANCHORING

1. Set the appliance in place and level left to right and front-to-back using spirit level.
2. Mark hole locations on floor through anchoring holes provided in flanged adjustable feet.
3. Remove appliance and drill holes in locations marked on floor and insert proper anchoring devices (not supplied).
4. Set unit back in position and re-level left to right and front to back.
5. Bolt and anchor appliance securely to the floor.
6. Seal bolts and flanged feet with silastic or equivalent compound.

	<p>WARNING: Do not connect the appliance to the electrical supply until after the gas connection has been made.</p>
---	--

GAS CONNECTIONS

All gas supply connections and any pipe joint compound used must be resistant to the action of propane gases.

The gas inlet is located under the control panel on the left-hand side.

Connect gas supply to the tilting braising pan. The gas supply line must be at least the equivalent of 3/4" iron pipe with an incoming pressure of approximately 7" W.C. (Water Column) for natural gas or 11" W.C. (Water Column) for propane gas. Make sure the pipes are clean and free of obstructions, dirt and piping compound.

Codes require that a gas shutoff valve be installed in the gas line ahead of the tilting braising pan.

Natural gas and propane gas braising pans are equipped with fixed orifices and no adjustment is necessary. Gas burner manifold is set at 3.5" W.C. (Water Column) for natural gas, and 10" W.C. (Water Column) for propane gas.



WARNING: Never use an open flame to check for gas leaks. Check all connections for leaks using soapy water before use.

After piping has been checked for leaks, all piping receiving gas should be fully purged to remove air.

3.0 OPERATION INSTRUCTIONS

	CAUTION: The appliance and its parts are hot. Use care when operating, cleaning and servicing the appliance.
--	---

BEFORE FIRST USE

Using a non-corrosive, grease-dissolving commercial cleaner, clean the protective metal oils from all surface parts and the interior of the tilting braising pan. Follow the cleaner manufacturer's directions. Rinse thoroughly and drain the pan. Wipe dry with a soft clean cloth.

CONTROLS (Figure 1)

- Green Ignition Light** - Will light when ignition has occurred.
- Red Temperature Light** - Will light when burners are supplying heat to the tilting braising pan.
- Thermostat** - When turned ON, will initiate electronic ignition system. Temperature settings are marked on the control panel in C and F.
- Manual Lift Crank Handle** - Used to manually raise and lower braising pan.

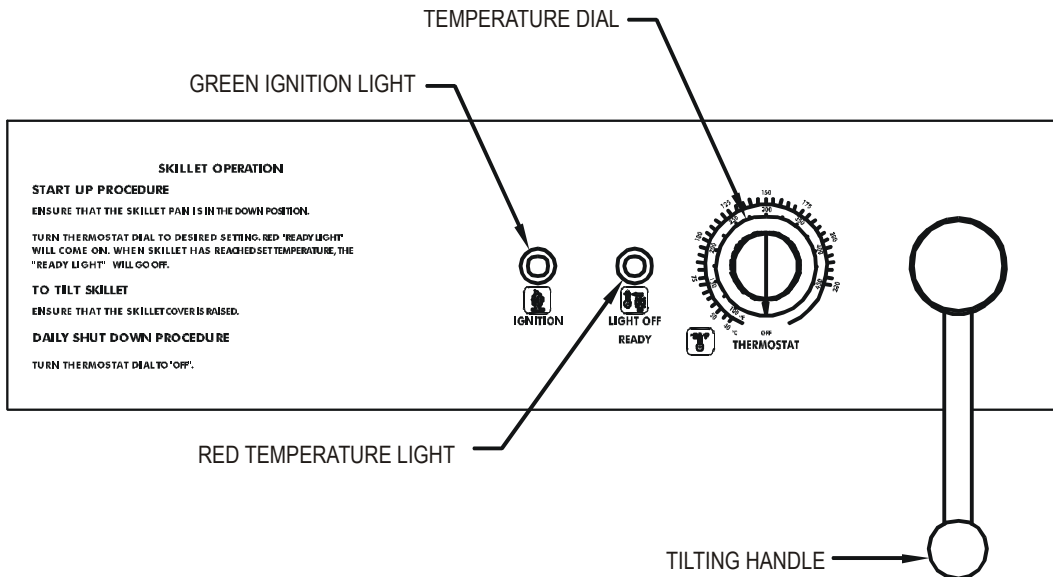

FIGURE 1

3.0 OPERATION INSTRUCTIONS (Continued)

START-UP PROCEDURE

1. Open manual gas shutoff valve.
2. Ensure that the braising pan is in the DOWN position.
3. Turn THERMOSTAT dial to desired setting. The red TEMPERATURE LIGHT will come on. This will turn on the electronic ignition which will light the burners.
4. If the green IGNITION LIGHT does not come on after 30 seconds, turn THERMOSTAT OFF and then ON again for restart.
5. When braising pan has reached set temperature, the red TEMPERATURE LIGHT will go off and the burners will shut off. The burners will cycle on and off thereafter to maintain set temperature. The red TEMPERATURE LIGHT will be on when the burners are on and off when burners are off.
6. If gas supply is interrupted during operation, turn THERMOSTAT dial to OFF position and turn gas supply OFF. Wait 5 minutes, then repeat Steps 1 through 4 to restart.
7. Turn THERMOSTAT to OFF when braising pan is not in use.

DAILY SHUTDOWN PROCEDURE

Turn THERMOSTAT dial to OFF. Close manual gas shutoff valve.

TILTING THE BRAISING PAN

1. DO NOT try to tilt braising pan with lid down.
2. Make sure the receiving pan is in place.
3. Turn crank handle clockwise to lift the braising pan and counterclockwise to lower the braising pan. When the braising pan is raised 5E or more, the gas supply will be turned off automatically. The braising pan will not operate once the pan has been tilted.
4. Food is poured through the removable strainer (Figure 2) into a food receiving pan positioned under the lip of the pouring spout (Figure 2).

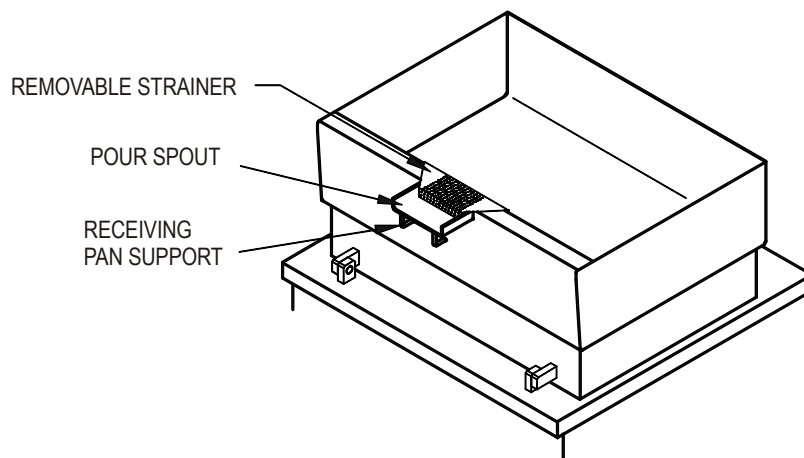

FIGURE 2

4.0 PERIODIC MAINTENANCE



WARNING: Disconnect the power supply to the appliance before cleaning or servicing.

CLEANING

After each use, allow the tilting braising pan to cool and clean it. Keep exposed cleanable areas of the tilting braising pan clean at all times. Do not get water in electrical box or any electrical component.

1. Thoroughly wash pan, pouring spout (See Figure 2), lid and exterior surfaces with detergent and warm water. If necessary, soak pan to remove food that is stuck to pan surface. Rinse thoroughly and wipe dry with a soft clean cloth.
2. Clean removable strainer and receiving pan support (see Figure 2) with detergent and warm water. Rinse thoroughly and wipe dry with a soft clean cloth.
3. Clean around burner air mixers and orifices (at rear of burner) if lint has accumulated.
4. Visually ensure tube lighter ports (Figure 3) are unobstructed.

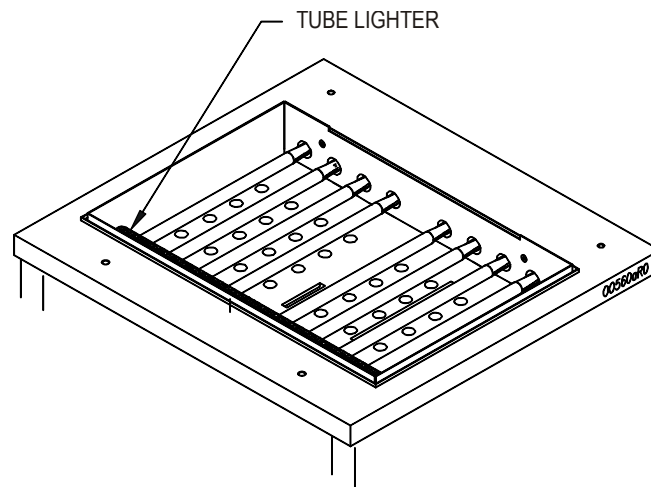

FIGURE 3

4.0 PERIODIC MAINTENANCE (Continued)



CAUTION: The appliance and its parts are hot. Use care when operating, cleaning and servicing the appliance.

ADJUSTMENTS

All tilting braising pans are adjusted at the factory.

At least twice a year, have an authorized service person clean and adjust the tilting braising pan for maximum performance.

5.0 COOKING GUIDELINES

The guidelines given below are suggested quantities, temperature settings, and **estimated** numbers of orders per load and per hour. When two temperatures are given, the first is to start the product, and the second to finish the product.

The following temperatures should be used:

	<u>Temperature (EF)</u>	
Simmering	200 Maximum	
Sautéing	225 - 275	
Searing	300 - 350	
Frying	325 - 375	
Grilling	350 - 450	

<u>ITEM</u>	<u>PORTION</u>	<u>TEMP (F)</u>	<u>BATCH/HR</u>	<u>BLG-30G PER LOAD</u> <u>QTY</u>	<u>PORTIONS</u>	<u>BLG-40G PER LOAD</u> <u>QTY</u>	<u>PORTIONS</u>
BREAKFAST FOODS							
Bacon	3 slices	350	12	2 lbs.	10	3 lbs.	15
Eggs							
- Boiled-Hard	1 egg	225	5	50 eggs	50	75 eggs	75
- Boiled-Soft	1 egg	225	8	50 eggs	50	75 eggs	75
- Fried	1 egg	400	4	30 eggs	30	45 eggs	45
- Poached	1 egg	225	5	36 eggs	36	60 eggs	60
- Scrambled	1-1/2 eggs	300-200	1	18 gal.	720	28 gal.	1100
French Toast	3 slices	450	7	35 slices	12	50 slices	17
Regular Oatmeal	½ cup	250	2	20 lbs. (100 cups)	500	40 lbs. (200 cups)	1000
Pancakes	2 each	400	10	30 ea.	15	50 ea.	25
FISH							
Clams	1 pt.	400	10	10 qts.	20	15 qts.	30
Fish Cakes	2 - 3 oz.	400	5	70 - 3 oz.	35	110 - 3 oz.	55
Haddock Fillet	4 oz.	400	4	60 - 4 oz.	60	90 - 4 oz.	90
Halibut Steak	5 oz.	450	3	60 - 4 oz.	60	90 - 4 oz.	90
Lobster	1 - 1 lb.	350	4	20 - 1 lb.	20	30 - 1 lb.	30
Swordfish	5 oz.	450	3	50 - 5 oz.	50	75 - 5 oz.	75

<u>ITEM</u>	<u>PORTION</u>	<u>TEMP (F)</u>	<u>BATCH/HR</u>	<u>BLG-30G PER LOAD</u>		<u>BLG-40G PER LOAD</u>	
				<u>QTY</u>	<u>PORTIONS</u>	<u>QTY</u>	<u>PORTIONS</u>
SAUCES, GRAVIES, SOUPS							
Brown Gravy	1 oz.	350 - 200	2	18 gal.	2300	35 gal.	4500
Cream Sauce	2 oz.	250 - 175	1	18 gal.	1150	35 gal.	2250
Cream Soup	6 oz.	200	1	18 gal.	375	35 gal.	725
French Onion Soup	6 oz.	225	1	18 gal.	350	35 gal.	700
Meat Sauce	4 oz.	350 - 200	1	18 gal.	575	35 gal.	1100
VEGETABLES							
<u>CANNED</u>	3 oz.	400	6	30 lbs.	125	45 lbs.	200
<u>FRESH</u>							
Beans, Wax, Green	3 oz.	400	3	25 lbs.	125	50 lbs.	250
Beets	3 oz.	400	1	30 lbs.	125	60 lbs.	300
Broccoli	3 oz.	400	3	25 lbs.	125	40 lbs.	200
Cabbage	3 oz.	400	5	20 lbs.	80	30 lbs.	125
Carrots	3 oz.	400	2	35 lbs.	150	70 lbs.	300
Cauliflower	3 oz.	250	5	15 lbs.	75	25 lbs.	125
Corn	1 ear	400	8	50 ears	50	75 ears	75
Potatoes	3 oz.	400	2	40 lbs.	200	60 lbs.	300
Spinach	4 oz.	250	10	6 lbs.	25	9 lbs.	35
Turnips	4 oz.	400	2	20 lbs.	100	30 lbs.	150
<u>FROZEN</u>							
Beans, French Green	3 oz.	400	6	15 lbs.	60	22-1/2 lbs.	90
Lima Beans	3 oz.	250	4	15 lbs.	60	22-1/2 lbs.	90
Broccoli	3 oz.	400	8	12 lbs.	50	18 lbs.	75
Sliced Carrots	3 oz.	250	6	15 lbs.	60	22-1/2 lbs.	90
Small Whole Carrots	3 oz.	250	3	15 lbs.	50	22-1/2 lbs.	90
Corn	3 oz.	250	18	15 lbs.	50	22-1/2 lbs.	90
Small Whole Onions	3 oz.	250	7	15 lbs.	50	22-1/2 lbs.	90
Peas	3 oz.	400	10	15 lbs.	75	22-1/2 lbs.	110
Spinach	3 oz.	400	3	15 lbs.	75	22-1/2 lbs.	110

<u>ITEM</u>	<u>PORTION</u>	<u>TEMP (F)</u>	<u>BATCH/HR</u>	<u>BLG-30G PER LOAD</u>		<u>BLG-40G PER LOAD</u>	
				<u>QTY</u>	<u>PORTIONS</u>	<u>QTY</u>	<u>PORTIONS</u>
DESSERTS, PUDDINGS, SWEET SAUCES							
Butterscotch Sauce	1 oz.	200	1	18 gal.	2300	35 gal.	4500
Cherry Cobbler	3 oz.	200	1	18 gal.	750	35 gal.	1500
Chocolate Sauce	1 oz.	200	1	18 gal.	2300	35 gal.	4500
Cornstarch Pudding	4 oz.	200	1	18 gal.	575	35 gal.	1100
Fruit Gelatin	3 oz.	250	2	18 gal.	750	35 gal.	1500
MEAT-POULTRY							
Bacon	3 slices	350	12	2 lbs.	10	3 lbs.	15
<u>BEEF</u>							
Amer. Chop Suey	6 oz.	400 - 225	2	18 gal.	350	35 gal.	700
Beef Stew	8 oz.	300	-	18 gal.	280	35 gal.	560
Corned Beef Hash	5 oz.	400	5	16 lbs.	50	25 lbs.	75
Cheeseburger	3 oz.	300	12	7 lbs.	35	10 lbs.	50
Hamburger	3 oz.	300	15	7 lbs.	35	10 lbs.	50
Meatballs	1 oz.	400-225	3	12-1/2 lbs.	65	18 lbs.	100
Pot Roast	2 oz.	350-200		120 lbs.	500	180 lbs.	750
Salisbury Steak	5 oz.	400	3	16 lbs.	50	24 lbs.	75
Sirloin Steak	6 oz.	400	5	15 lbs.	40	22-1/2 lbs.	60
Swiss Steak	4 oz.	300-200	1	25 lbs.	110	40 lbs.	160
<u>CHICKEN</u>							
Pan Fried	2-1/4's	350	3	50 pieces	25	80 pieces	40
Whole	2 oz.	350-200		16 - 5 lbs.	200	24-5 lbs.	265
<u>FRANKFURTERS</u>							
Grilled	2 oz.	300	8	22 lbs.	176	33 lbs.	264
Boiled	2 oz.	250	12	16 lbs.	128	25 lbs.	200
<u>PORK</u>							
Ham Steak	3 oz.	400	8	10 lbs.	50	15 lbs.	75
Sausage Links	3 links	350	7	30 lbs.	120	45 lbs.	180
Pork Chops	5 oz.	350	4	15 lbs.	50	25 lbs.	75

<u>ITEM</u>	<u>PORTION</u>	<u>TEMP (F)</u>	<u>BATCH/HR</u>	<u>BLG-30G PER LOAD</u>		<u>BLG-40G PER LOAD</u>	
				<u>QTY</u>	<u>PORTIONS</u>	<u>QTY</u>	<u>PORTIONS</u>
MEAT-POULTRY (continued)							
<u>TURKEY</u>							
Off Carcass	2 oz.	400-200	–	3 26-30 lbs.	200	4 26-30 lbs.	275
On Carcass	2 oz.	400-200	–	4 16-20 lbs.	175	6 16-20 lbs.	265
MISCELLANEOUS							
Grilled Cheese Sandwich	1 sandwich	400	8	35 sandwiches	35	50 sand.	50
Macaroni & Cheese	8 oz.	200	2	18 gal.	300	35 gal.	525
Rice	4 oz.	350-225	1	20 lbs. raw	320	40 lbs. raw	650
Spaghetti	4 oz.	350-225	2	8 lbs. raw	200	12 lbs. raw	300

6.0 TROUBLESHOOTING

Burners do not come on:

1. Gas supply to unit is "OFF".
2. Manual shut off valve is "OFF".
3. Thermostat is not turned "ON".
4. Pan not in lowest position.
5. Ignition control not functioning.
6. Unit electrical supply is not plugged in or turned on.
7. Braising pan has overheated and burners were shut off by high-limit thermostat. Wait for pan to cool.

Burners produce carbon deposits:

1. Wrong size orifices.
2. Burner air not adjusted properly.
3. Wrong gas supply.
4. Incorrect pressure at supply.