



SSUC Series Undercounter Refrigerator

MODELS #178SSUC48RHC

CABINET CONSTRUCTION

Heavy duty construction includes a 304 type stainless steel interior and a 430 type stainless steel exterior, resulting in strength, durability, and an attractive, sleek appearance. Foamed-in-place CFC- and HCFC-free polyurethane insulation enhances the structural strength of the cabinet and helps increase energy efficiency. One-piece rear grill is easily removed for cleaning and servicing. 2 doors feature easy-to-use recessed handles for quick interior access. Doors stay open past 90° for easy loading, but will self-close under 90° to save energy.

REFRIGERATION SYSTEM

Environmentally safe R290 refrigerant. Rear-mounted condensing unit positioned for easy maintenance.

SHELVING

2 white epoxy-coated steel shelves included. Each accommodate up to 90 lb.

MODEL FEATURES

Copper evaporator coil eliminates the potential of corrosion. Interior wall-mounted thermometer for easy temperature monitoring. Preprogrammed digital controller features auto-defrost function.

PROJECT: _____
MODEL: _____ SERIAL#: _____
ITEM #: _____ QUANTITY: _____
APPROVAL: _____ DATE: _____

SSUC SERIES - UNDERCOUNTER REFRIGERATOR

Increase cold food prep storage in your kitchen

SPECIAL FEATURES

- Eco-friendly R290 hydrocarbon refrigerant
- Strong and sleek 430 type stainless steel exterior
- 304 type stainless steel interior maintains temperature from 33°F - 40°F
- Two epoxy-coated steel shelves accommodate up to 90 lb. each
- Foamed-in-place polyurethane insulation
- Easy-to-read digital temperature controller and auto-defrost function
- 115V; 1/5hp



WARRANTY

RESIDENTIAL: Avantco assumes no liability parts or labor coverage for component failure, factory defect or any other damages for unit installed in non-commercial foodservice or residential applications.



★ Conforms to UL & NSF-7 Standards



TECHNICAL DATA

Dimensions

Exterior Dimensions	47¼"W x 29½"D x 35¼"H
Interior Dimensions	42½"W x 22⅞"D x 23½"H
Working Height	35¼"
Net Volume	11.2 cu. ft.
Net Weight	214 lb.
Gross Weight	275 lb.
Packaging Dimensions	50"W x 32¼"D x 38½"H

Cooling

Temperature Range	33°F - 40°F
Refrigerant	R290
Max. Ambient Temperature	100°F
Defrosting	Automatic
Temperature Controller	Digital
Horsepower	1/5

Construction

Exterior Material	Type 430 Stainless Steel
Interior Material	Type 304 Stainless Steel
Insulation Material	Foamed-in -place polyurethane
Shelf Size	(2) 20 ¹³ / ₁₆ " x 17 ¹ / ₁₆ "
Shelf Material	Epoxy-coated steel
Shelf Load Capacity	90 lb.

Electrical

Voltage	115
Amps	2.7
Hz	60
Phase	1
Plug Type	NEMA 5-15P
Electrical Cord Length	84"

PLAN VIEW

FRONT VIEW

SIDE VIEW

TOP VIEW

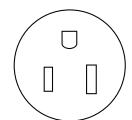
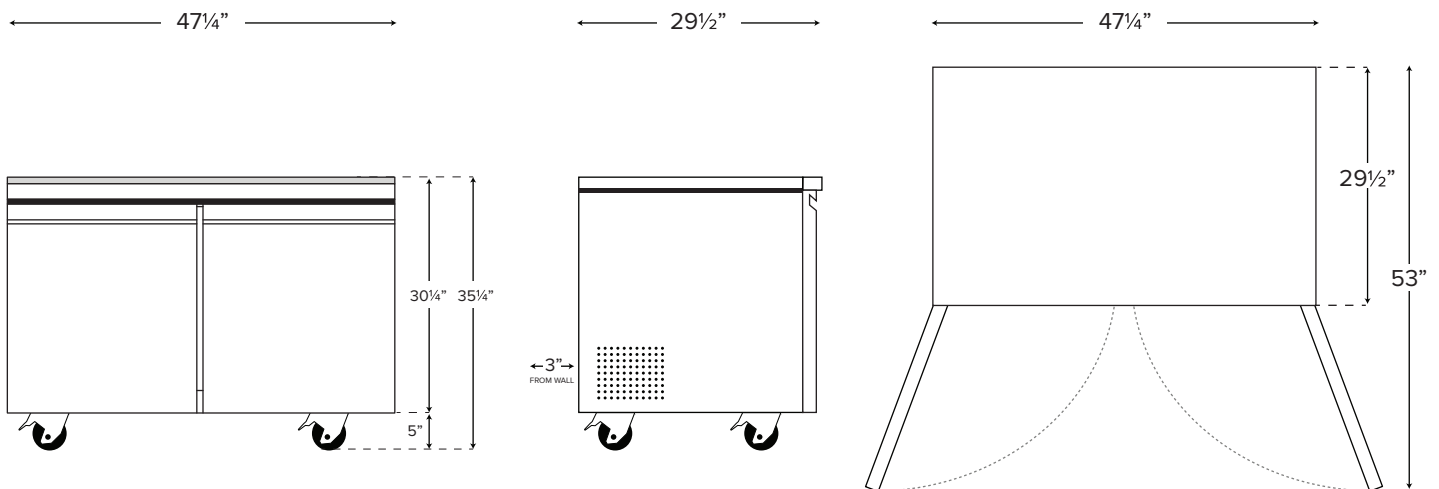

NEMA 5-15P