

INSTALLATION/OPERATION & TECHNICAL MANUAL

FOR JACKSON MODELS:

AJ-64CE

AJ-86CE

AJ-100CE

AJ-64CS

AJ-86CGP

AJ-100 CGP

AJ-64CGP

AJ-86CS

AND ASSOCIATED OPTION PACKAGES INCLUDING:

SIDE LOADER
D226 EXTERNAL STEAM BOOSTER



MANUFACTURERS WARRANTY

ONE YEAR LIMITED PARTS & LABOR WARRANTY

ALL NEW JACKSON DISHWASHERS ARE WARRANTED TO THE ORIGINAL PURCHASER TO BE FREE FROM DEFECTS IN MATERIAL OR WORKMANSHIP, UNDER NORMAL USE AND OPERATION FOR A PERIOD OF (1) ONE YEAR FROM THE DATE OF PURCHASE, BUT IN NO EVENT TO EXCEED (18) EIGHTEEN MONTHS FROM THE DATE OF SHIPMENT FROM THE FACTORY.

Jackson WWS agrees under this warranty to repair or replace , at its discretion, any original part which fails under normal use due to faulty material or workmanship during the warranty period, providing the equipment has been unaltered, and has been properly installed, maintained and operated in accordance with the applicable factory instruction manual furnished with the machine and the failure is reported to the authorized service agency within the warranty period. This includes the use of factory specified genuine replacement parts, purchased directly from a Jackson authorized parts distributor or service agency. Use of generic replacement parts may create a hazard and void warranty certification.

The labor to repair or replace such failed part will be paid by Jackson WWS, within the continental United States, Hawaii and Canada, during the warranty period provided a Jackson WWS authorized service agency, or those having prior authorization from the factory, performs the service. Any repair work by persons other than a Jackson WWS authorized service agency is the sole responsibility of the customer. Labor coverage is limited to regular hourly rates, overtime premiums and emergency service charges will not be paid by Jackson WWS.

Accessory components not installed by the factory carry a (1) one year parts warranty only. Accessory components such as table limit switches, pressure regulators, pre rinse units, etc. that are shipped with the unit and installed at the site are included. Labor to repair or replace these components is not covered by Jackson WWS.

This warranty is void if failure is a direct result from shipping, handling, fire, water, accident, misuse, acts of god, attempted repair by unauthorized persons, improper installation, if serial number has been removed or altered, or if unit is used for purpose other than it was originally intended.

TRAVEL LIMITATIONS

Jackson WWS limits warranty travel time to (2) two hours and mileage to (100) one hundred miles. Jackson WWS will not pay for travel time and mileage that exceeds this, or any fees such as those for air or boat travel without prior authorization.

WARRANTY REGISTRATION CARD

The warranty registration card supplied with the machine must be returned to Jackson WWS within 30 days to validate the warranty.

REPLACEMENT PARTS WARRANTY

Jackson replacement parts are warranted for a period of 90 days from the date of installation or 180 days from the date of shipment from the factory, which ever occurs first.

PRODUCT CHANGES AND UPDATES

Jackson WWS reserves the right to make changes in design and specification of any equipment as engineering or necessity requires.

THIS IS THE ENTIRE AND ONLY WARRANTY OF JACKSON WWS. JACKSON'S LIABILITY ON ANY CLAIM OF ANY KIND, INCLUDING NEGLIGENCE, WITH RESPECT TO THE GOODS OR SERVICES COVERED HEREUNDER, SHALL IN NO CASE EXCEED THE PRICE OF THE GOODS OR SERVICES OR PART THEREOF WHICH GIVES RISE TO THE CLAIM.

THERE ARE NO WARRANTIES, EXPRESSED OR IMPLIED, INCLUDING FOR FITNESS OR MERCHANTABILITY, THAT ARE NOT SET FORTH HEREIN, OR THAT EXTEND BEYOND THE DURATION HEREOF. UNDER NO CIRCUMSTANCES WILL JACKSON WWS BE LIABLE FOR ANY LOSS OR DAMAGE, DIRECT OR CONSEQUENTIAL, OR FOR THE DAMAGES IN THE NATURE OF PENALTIES, ARISING OUT OF THE USE OR INABILITY TO USE ANY OF ITS PRODUCTS.

ITEMS NOT COVERED

This warranty does not cover cleaning or deliming of the unit or any component such as, but not limited to, wash arms, rinse arms or strainers at anytime. Nor does it cover adjustments such as, but not limited to timer cams, thermostats or doors, beyond 30 days from the date of installation. In addition, the warranty will only cover the replacement of wear items such as curtains, drain balls, door guides or gaskets during the first 30 days after installation. Also, not covered are conditions caused by the use of incorrect (non-Commercial) grade detergents, incorrect water temperature or pressure, or hard water conditions.



CALL 1-888-800-5672 TO REGISTER THIS PRODUCT!
FAILURE TO DO SO WILL VOID THE WARRANTY!

LLAME AL 1-888-800-5672 PARA REGISTRAR ESTE PRODUCTO !
ALNO HACERLO LA GARANTIA SERA ANULADA!

S.V.P. APPELER 1-888-800-5672 POUR ENREGISTRER CE PRODUIT,
LA GARANTIE SERA ANNULEE POUR TOUT PRODUIT NON - ENREGISTRE

REVISION	REVISION DATE	MADE BY	APPLICABLE ECN	DETAILS
D	04-06-05	MAW	6999, 7193 7217, 7064 7212, 7259 6685, 7096 6964, 7006	Updated drawings for limit switch actuators. Changed AJ-86 drain plumbing copper lengths. Added rack rail stabilizer kit. Replaced heater 04540-121-76-93 with 04540-002-29-82. Updated installation instructions. Added 3 instruction sheets for limit switches. Added instruction sheet for curtains. Added AJ-86CGP & AJ-100CGP models.
E	02-02-06	MAW	7600,7558	Added gas exhaust fan schematic, updated electric exhaust fan schematic, updated dimensions pages. Replace Drain Weldment 05700-021-68-28 with 05700-002-51-12.
F	05-02-06	MAW	7572, 7730 7634, 7743 7428, 7571 7554, 7475 7463, 7462 7367, 7789	Pawl bar for AJ-86 R-L unit with a side loader option. Updated scrap basket drawings. Vent cowl assembly for a hooded side loader. Service instructions for replacing wash/rinse motors. Added prison pawl bar packages. Thermostat replacement kits, updated drain quench assembly, replaced wash thermostat 05930-121-67-72 with 05930-003-13-65. Heater replacment instructions. Updated steam booster schematic. Rinse fill motor assembly. Wash, rinse & PSI decals. Update door assembly numbers.Drain quench kit.
PG, 116	04-19-07	MAW	7898	Added 09905-003-32-20 fan load decal.
5 thru 22, 104	09-29-2007	MAW	N/A	Updated dimensions page. Removed alternate table limit switches.
G	10-09-2009	KJS	8044	Changed the part from a weldment (05700-021-67-50) to a casting (09515-003-58-12).
H	08-12-2013	RLC	QOF NDB-219	Updated Manufacturer information.
I	09-15-2014	KAP	N/A	Updated Jackson Logo
J	02-06-2014	KAP	N/A	Updated temperatures on pg's 7, 8, 13, 14, 19, and 20. Updated drawing on pg. 39
K	10-06-2015	KAP	N/A	Updated rack rail assembly on pg. 97



AJ-64CS

AJ = AJ series of rack conveyors

64 = 64" wide machine

86 = 86" wide machine

100 = 100" wide machine

CE = Electrically heated, hot water sanitizing machine

CS = Steam heated, hot water sanitizing machine

CGP = Gas heated, hot water sanitizing machine

Model: _____

Serial No.: _____

Installation Date: _____

Service Rep. Name: _____

Phone No.: _____

Jackson WWS ,INC. provides technical support for all of the dishmachines detailed in this manual. We strongly recommend that you refer to this manual before making a call to our technical support staff. Please have this manual with you when you call so that our staff can refer you, if necessary, to the proper page. Technical support is available from 8:00 a.m. to 5:00 p.m. (EST), Monday through Friday. Technical support is not available on holidays. Contact technical support toll free at 1-888-800-5672. Please remember that technical support is available for service personnel only.

TABLE OF CONTENTS

<u>SECTION</u>	<u>DESCRIPTION</u>	<u>PAGE</u>
I.	SPECIFICATION INFORMATION	
	Operating Characteristics	2
	Electrical Requirements	3
	D226 Steam Booster Parameters	4
	AJ-64 Electric - Left to Right	5
	AJ-64 Electric - Right to Left	6
	AJ-64 Gas - Left to Right	7
	AJ-64 Gas - Right to Left	8
	AJ-64 Steam - Left to Right	9
	AJ-64 Steam - Right to Left	10
	AJ-86 Electric - Left to Right	11
	AJ-86 Electric - Right to Left	12
	AJ-86 Gas - Left to Right	13
	AJ-86 Gas - Right to Left	14
	AJ-86 Steam - Left to Right	15
	AJ-86 Steam - Right to Left	16
	AJ-100 Electric - Left to Right	17
	AJ-100 Electric - Right to Left	18
	AJ-100 Gas - Left to Right	19
	AJ-100 Gas - Right to Left	20
	AJ-100 Steam - Left to Right	21
	AJ-100 Steam - Right to Left	22
	Side Loader (Left to Right) Dimensions	23
	Side Loader (Right to Left) Dimensions	24
	Side Loader (Installed) Dimensions	25
	D226 Steam Booster Dimensions	26
	D226 Steam Booster Plumbing Line Drawings	27
	Typical Electric and Gas Booster Dimensions	28
II.	INSTALLATION & OPERATION INSTRUCTIONS	
	Installation Instructions	30
	Delimiting Operations	33
	Curtain Installation Diagram	34
	Side Loader Installation & Operation Instructions	35
	D226 Steam Booster Installation & Operation Instructions	36
	Gas Conveyor Hose Installation	38
	Dishmachine Operating Instructions	40
	Detergent Control	42
	Striker Plate Limit Switch Installation Instructions	43
III.	PREVENTATIVE MAINTENANCE	
	General Maintenance	45
	D226 Maintenance	46
	Lubrication Chart for Drive Gear	47
	Drive Motor Gear Reducer Preventative Maintenance	48
IV.	TROUBLESHOOTING SECTION	
	Common Problems	50
	D226 Common Problems	52

TABLE OF CONTENTS

PARTS

VI.	PARTS SECTION	
	AJ-64 Control Box Assembly	54
	AJ-86/AJ-100 Control Box Assembly	56
	Motor Overload Chart	58
	Heater Box Assembly	59
	Heater Assembly	60
	Frame Weldments/Front Dress Panels	62
	Prewash Plumbing Assembly	63
	Incoming Plumbing Assembly	64
	Rinse Header Plumbing Assembly (CGP Models)	66
	External Electric Booster Option Incoming Plumbing	67
	External Electric Booster Option Outlet Plumbing	68
	WPRK Plumbing Option	69
	3/4" Solenoid Valve & 3/4" NPT Vacuum Breaker Repair Parts Kits	70
	Steam Unit Wash Tank Coil Assembly	71
	Steam Inlet Plumbing (Left to Right)	72
	Steam Inlet Plumbing (Right to Left)	74
	Steam Outlet Plumbing (Left to Right)	76
	Steam Outlet Plumbing (Right to Left)	77
	Gas Coil Assembly (CGP Models)	78
	Rinse Booster Tank Assembly (CGP Models)	79
	Recirculating Pump Assembly (CGP Models)	80
	Hose Connections (CGP Models)	81
	AJ-64 Series Drain Plumbing Assemblies	82
	AJ-86 & AJ-100 Drain Plumbing Assemblies (Left to Right)	83
	AJ-86 & AJ-100 Drain Plumbing Assemblies (Right to Left)	84
	Drain Quench Assembly	85
	Prewash & Wash Motor Assemblies	86
	Prewash & Wash Pump Weldments	87
	Prewash & Upper Wash Arm Assemblies	88
	Lower Wash Arm Assembly	89
	Upper & Lower Power Rinse Arm Assemblies	90
	Final Rinse Assembly	91
	Drive Assembly	92
	Door Assemblies	94
	Pawl Bar Roller Bracket	95
	AJ-64 & AJ-86 Pawl Bar Assemblies	96
	AJ-64 Rack Rail Assembly	97
	Miscellaneous Parts & Weldments	98
	Manifolds/Strainer Support Weldments	99
	Strainers	100
	Float Switch Components/Scrap Basket Assembly	101
	Curtains/Tub Magnets	102
	Vent Cowl Assembly/Vent Scoop Option	103
	Exhaust Fan Control Option/Table Limit Switch Options	104
	SIDE LOADER SECTION	
	Side Loader Track Assembly/Leg Replacements	105
	Side LoaderPawl Bar Assemblies	106
	Side Loader Vent Cowl Option	107
	D226 STEAM BOOSTER SECTION	
	Control Box Assembly	108
	Plumbing Assembly	109
	Go*Box Components	111
	Rinse Fill Motor Option	112

TABLE OF CONTENTS

ELECTRICAL SCHEMATICS

VII.	ELECTRICAL SCHEMATICS	
	AJ-64CE	
	208-230 Volt, 60 Hz, 1 Phase Primary Side	114
	208-230 Volt, 60 Hz, 1 Phase Secondary Side	115
	208-230 Volt, 60 Hz, 3 Phase Primary Side	116
	208-230 Volt, 60 Hz, 3 Phase Secondary Side	117
	460-575-600 Volt, 60 Hz, 3 Phase Primary Side	118
	460-575-600 Volt, 60 Hz, 3 Phase Secondary Side	119
	AJ-64CS	
	208-230 Volt, 60 Hz, 1 Phase Primary Side	120
	208-230 Volt, 60 Hz, 1 Phase Secondary Side	121
	208-230 Volt, 60 Hz, 3 Phase Primary Side	122
	208-230 Volt, 60 Hz, 3 Phase Secondary Side	123
	460-575-600 Volt, 60 Hz, 3 Phase Primary Side	124
	460-575-600 Volt, 60 Hz, 3 Phase Secondary Side	125
	AJ-86CE & AJ-100CE	
	208-230 Volt, 60 Hz, 1 Phase Primary Side	126
	208-230 Volt, 60 Hz, 1 Phase Secondary Side	127
	208-230 Volt, 60 Hz, 3 Phase Primary Side	128
	208-230 Volt, 60 Hz, 3 Phase Secondary Side	129
	460-575-600 Volt, 60 Hz, 3 Phase Primary Side	130
	460-575-600 Volt, 60 Hz, 3 Phase Secondary Side	131
	AJ-86CS & AJ-100CS	
	208-230 Volt, 60 Hz, 1 Phase Primary Side	132
	208-230 Volt, 60 Hz, 1 Phase Secondary Side	133
	208-230 Volt, 60 Hz, 3 Phase Primary Side	134
	208-230 Volt, 60 Hz, 3 Phase Secondary Side	135
	460-575-600 Volt, 60 Hz, 3 Phase Primary Side	136
	460-575-600 Volt, 60 Hz, 3 Phase Secondary Side	137
	AJ-86CGP & AJ100CGP	
	208-230 Volt, 60 Hz, 1 Phase Primary Side	138
	208-230 Volt, 60 Hz, 1 Phase Secondary Side	139
	208-230 Volt, 60 Hz, 3 Phase Primary Side	140
	208-230 Volt, 60 Hz, 3 Phase Secondary Side	141
	460-575-600 Volt, 60 Hz, 3 Phase Primary Side	142
	460-575-600 Volt, 60 Hz, 3 Phase Secondary Side	143
	Exhaust Fan Hook-Up Schematic	144
	D226 Steam Booster/Drain Quench/Conveyor Side Loader Schematics	145
VIII.	MAINTENANCE & REPAIR CENTERS	146

SECTION 1: SPECIFICATION INFORMATION

SECTION 1: SPECIFICATION INFORMATION

OPERATING CHARACTERISTICS

RACKS PER HOUR:

AJ-64-86-100CE/CS/CGP 287

DISHES OR GLASSES PER HOUR:

AJ-64-86-100CE/CS/CGP 7200

PREWASH TANK CAPACITY (GALLONS):

AJ-86CE/CS/CGP 16
AJ-100CE/CS/CGP 16

WASH TANK CAPACITY (GALLONS):

AJ-64-86-100CE/CS/CGP 15.4

POWER RINSE TANK CAPACITY (GALLONS):

AJ-86CE/CS/CGP 15.4
AJ-100CE/CS/CGP 15.4

PREWASH PUMP CAPACITY (GPM):

AJ-86CE/CS/CGP 120
AJ-100CE/CS/CGP 270

WASH PUMP CAPACITY

GALLONS PER MINUTE (ALL MODELS): 270

POWER RINSE PUMP CAPACITY

GALLONS PER MINUTE (ALL MODELS): 270

VENTING REQUIREMENTS (CFM)(100% CAP.):

INPUT END 200
OUTPUT END 400
TOTAL 600

CONVEYOR SPEED (FPM):

AJ-64-86-100CE/CS/CGP MACHINES 8.0

GALLONS PER RACK:

AJ-64-86-100CE/CS/CGP MACHINES .77

WATER TEMPERATURES:

AJ-64-86-100CE/CS/CGP MODELS:

WASH (MINIMUM) 150°F
POWER RINSE (MINIMUM) 160°F
FINAL RINSE (MINIMUM) 180°F

FLOW PRESSURE (PSI) 20 ± 5

FLOWRATE (GPM):

AJ-64-86-100CE/CS/CGP 3.7

STEAM COIL TANK HEAT (CS MODELS ONLY):

STEAM INLET PRESSURE (PSIG) 10-20
STEAM CONNECTION NPT 3/4"
CONSUMPTION @ 15 PSIG (lbs/hr):
AJ-64-86-100CS/CSL 100

MOTOR ELECTRICAL CHARACTERISTICS:

DRIVE MOTOR HP 1/4
WASH MOTOR HP 2
POWER RINSE MOTOR HP 2
PREWASH MOTOR HP:
AJ-86 MODELS 1
AJ-100 MODELS 2

NOTE: Typical Electrical Circuit is based upon (1) 125% of the full amperage load of the machine and (2) typical fixed-trip circuit breaker sizes as listed in the NEC 2002 Edition. Local codes may require more stringent protection than what is displayed here. Always verify with your electrical service contractor that your circuit protection is adequate and meets all applicable national and local codes. These numbers are provided in this manual simply for reference and may change without notice at any given time.

SECTION 1: SPECIFICATION INFORMATION
ELECTRICAL REQUIREMENTS

AJ-64CE MODELS

<u>VOLTS</u>	<u>PH</u>	<u>HZ</u>	<u>TOTAL AMPS</u>	<u>TYPICAL ELECTRICAL CIRCUIT</u>
208	1	60	139 A	175 AMP
230	1	60	128 A	175 AMP
208	3	60	82 A	110 AMP
230	3	60	76 A	100 AMP
460	3	60	38 A	50 AMP

AJ-86CE MODELS

<u>VOLTS</u>	<u>PH</u>	<u>HZ</u>	<u>TOTAL AMPS</u>	<u>TYPICAL ELECTRICAL CIRCUIT</u>
208	1	60	145 A	200 AMP
230	1	60	134 A	175 AMP
208	3	60	86 A	110 AMP
230	3	60	79 A	100 AMP
460	3	60	39 A	50 AMP

AJ-64CS MODELS

<u>VOLTS</u>	<u>PH</u>	<u>HZ</u>	<u>TOTAL AMPS</u>	<u>TYPICAL ELECTRICAL CIRCUIT</u>
208	1	60	19 A	25 AMP
230	1	60	19 A	25 AMP
208	3	60	13 A	20 AMP
230	3	60	13 A	20 AMP
460	3	60	7 A	15 AMP

AJ-86CGP MODELS

<u>VOLTS</u>	<u>PH</u>	<u>HZ</u>	<u>TOTAL AMPS</u>	<u>TYPICAL ELECTRICAL CIRCUIT</u>
208	1	60	26 A	35 AMP
230	1	60	26 A	35 AMP
208	3	60	17 A	25 AMP
230	3	60	17 A	25 AMP
460	3	60	9 A	15 AMP

AJ-86CS MODELS

<u>VOLTS</u>	<u>PH</u>	<u>HZ</u>	<u>TOTAL AMPS</u>	<u>TYPICAL ELECTRICAL CIRCUIT</u>
208	1	60	25 A	35 AMP
230	1	60	25 A	35 AMP
208	3	60	16 A	20 AMP
230	3	60	16 A	20 AMP
460	3	60	8 A	15 AMP

SECTION 1: SPECIFICATION INFORMATION

ELECTRICAL REQUIREMENTS (CONTINUED)/D226 STEAM BOOSTER PARAMETERS

AJ-100CE MODELS

<u>VOLTS</u>	<u>PH</u>	<u>HZ</u>	<u>TOTAL AMPS</u>	<u>TYPICAL ELECTRICAL CIRCUIT</u>
208	1	60	148 A	200 AMP
230	1	60	136 A	175 AMP
208	3	60	88 A	110 AMP
230	3	60	81 A	110 AMP
460	3	60	41 A	60 AMP

AJ-100CGP MODELS

<u>VOLTS</u>	<u>PH</u>	<u>HZ</u>	<u>TOTAL AMPS</u>	<u>TYPICAL ELECTRICAL CIRCUIT</u>
208	1	60	28 A	35 AMP
230	1	60	28 A	35 AMP
208	3	60	19 A	25 AMP
230	3	60	19 A	25 AMP
460	3	60	10 A	15 AMP

AJ-100CS MODELS

<u>VOLTS</u>	<u>PH</u>	<u>HZ</u>	<u>TOTAL AMPS</u>	<u>TYPICAL ELECTRICAL CIRCUIT</u>
208	1	60	28 A	35 AMP
230	1	60	28 A	35 AMP
208	3	60	18 A	25 AMP
230	3	60	18 A	25 AMP
460	3	60	9 A	15 AMP

NOTE: Always refer to the machine data plate for specific electrical and water requirements. The material provided on this page is for reference only and may be subject to change without notice.

D226 STEAM BOOSTER

ELECTRICAL REQUIREMENTS:

VOLTAGE (V)	208-230
FREQUENCY (HZ)	60
PHASE	SINGLE

WATER REQUIREMENTS:

INCOMING WATER TEMPERATURE (MINIMUM)	110°F
FLOW PRESSURE (PSI)	20 ± 5

STEAM REQUIREMENTS:

INCOMING STEAM PRESSURE (PSIG)	15-25
--------------------------------	-------

HEAT EXCHANGER SPECIFICATIONS:*

TUBESIDE WORKING PRESSURE (PSI)	125
SHELLSIDE WORKING PRESSURE (PSI)	125
TUBESIDE HYDROSTATIC TEST PRESSURE (PSI)	250
SHELLSIDE HYDROSTATIC TEST PRESSURE (PSI)	188
MAXIMUM OPERATING TEMPERATURE	295°F
MAXIMUM SHELLSIDE STEAM PRESSURE (PSI)	125

* - Indicates typical design criteria but is subject to change without notice. For more information, contact your authorized Jackson service representative.

WATER OUTLET SAFETY VALVE

SET PRESSURE (PSI):	125
STEAM RELIEF VALVE SET PRESSURE (PSI):	50

SECTION 1: SPECIFICATION INFORMATION

AJ-64 ELECTRIC - LEFT TO RIGHT

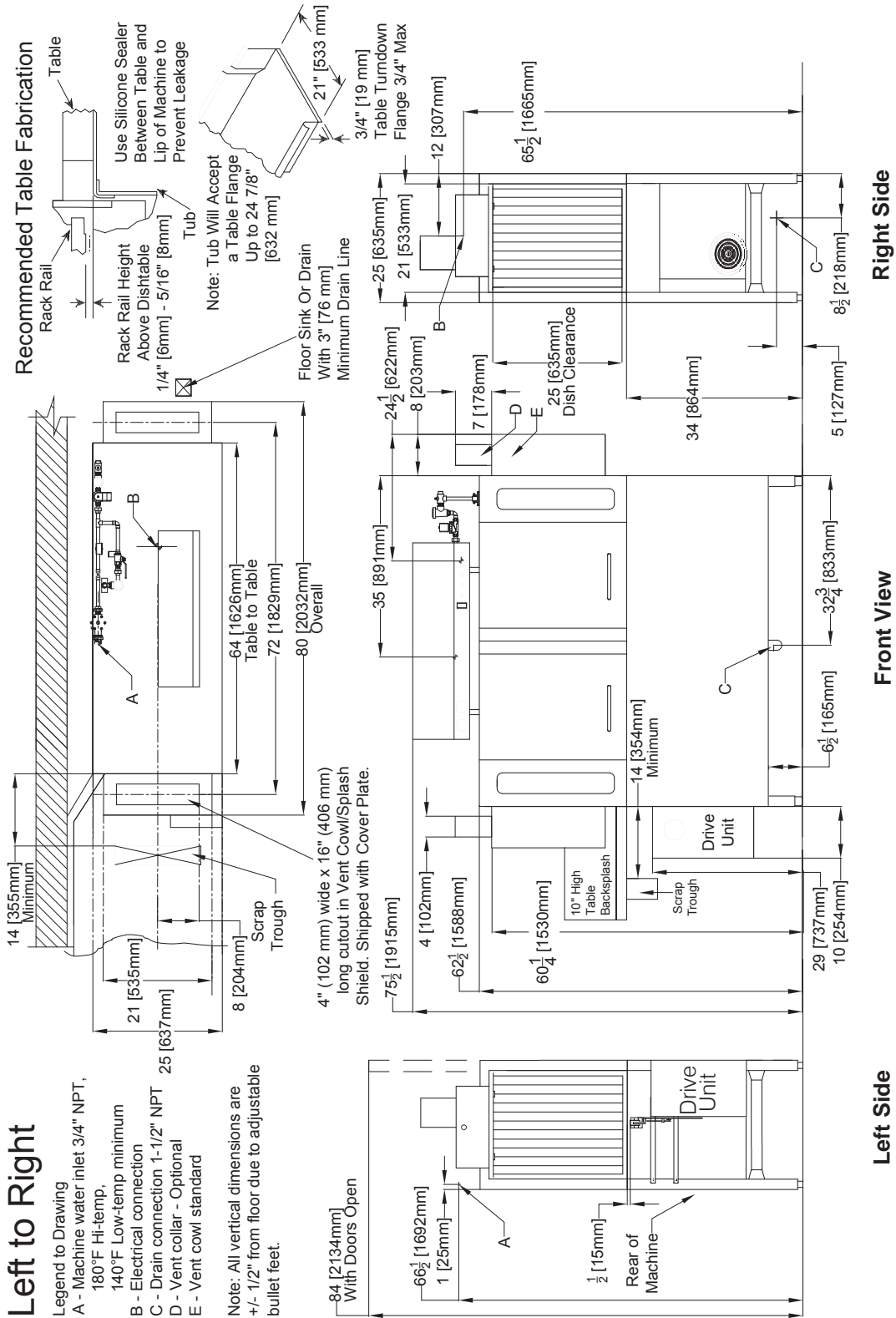

SECTION 1: SPECIFICATION INFORMATION

AJ-64 ELECTRIC - RIGHT TO LEFT

Right to Left

Legend to Drawing

- A - Machine water inlet 3/4" NPT, 180°F HI-temp, 140°F Low-temp minimum
- B - Electrical connection
- C - Drain connection 1-1/2" NPT
- D - Vent collar - Optional
- E - Vent cowl standard

Note: All vertical dimensions are +/- 1/2" from floor due to adjustable bullet feet.

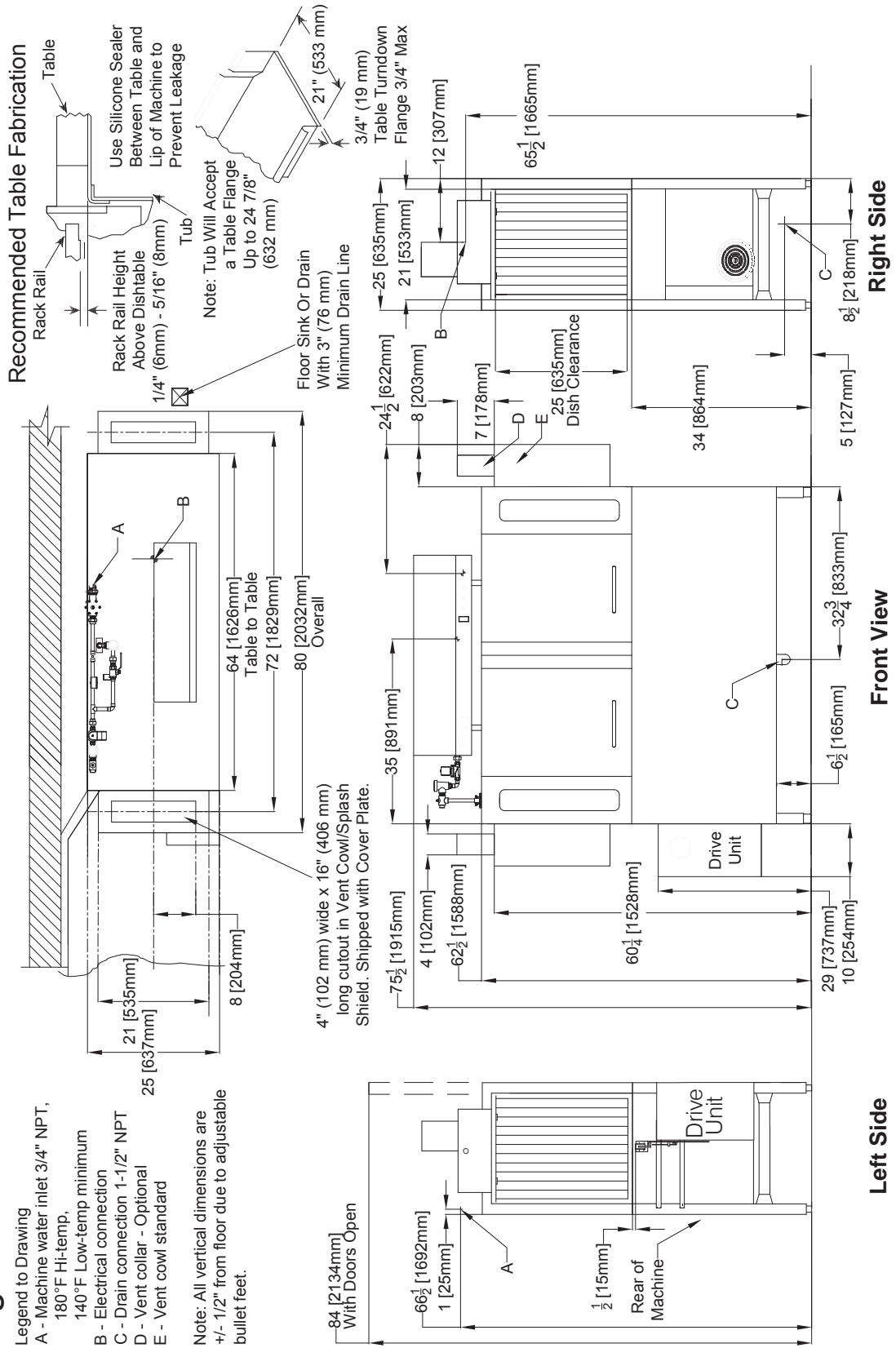

SECTION 1: SPECIFICATION INFORMATION

AJ-64 GAS - LEFT TO RIGHT

Left to Right

Legend to Drawing

- A - Machine water inlet 3/4" NPT, 110° F - 140° F Hi-temp, 140°F Low-temp minimum
- B - Electrical connection
- C - Drain connection 1-1/2" NPT
- D - Vent collar - Optional
- E - Vent cowl standard
- F - 3/4" NPT 180°F Water Inlet for wash tank fill, final rinse, & tank heating. From gas booster heater. Interconnecting hose provided by manufacturer.
- G - 3/4" NPT 140°F Water inlet for gas booster heater.
- H - 3/4" NPT 180°F Water Outlet connection to line on dishmachine. Connection hose provided by manufacturer.
- J - 3/4" NPT Gas Connection
- K - 4" OD Vent pipe connection. Flue to be installed to meet local codes by installing contractor.

Note: All vertical dimensions are +/- 1/2" from floor due to adjustable bullet feet.

Recommended Table Fabrication

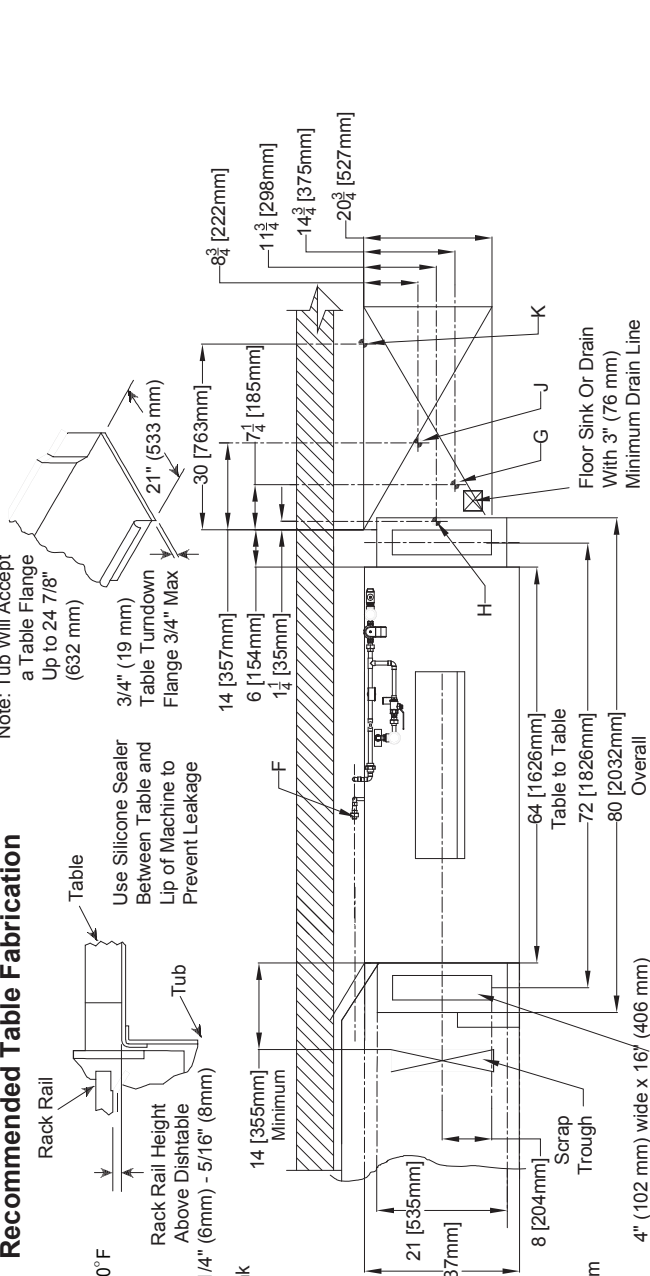

Note: Tub Will Accept a Table Flange Up to 24 7/8" (632 mm)

Use Silicone Sealer Between Table and Lip of Machine to Prevent Leakage

3/4" (19 mm) Table Turndown Flange 3/4" Max

30 [763mm]

8 3/4 [222mm]

11 3/4 [298mm]

14 1/2 [375mm]

20 3/4 [527mm]

7 1/4 [185mm]

1 1/4 [35mm]

6 [154mm]

3/4 [19 mm] Table Turndown Flange 3/4" Max

21 [533 mm]

25 [635mm]

24 1/2 [622mm]

8 [203mm]

7 [178mm]

31 1/2 [795mm]

26 1/2 [673mm]

36 [914mm]

6 [152mm]

6 1/2 [165mm]

35 [891mm]

4 [102mm]

62 1/2 [1588mm]

60 1/4 [1530mm]

10 [254mm]

29 [737mm]

10 [254mm]

32 3/4 [833mm]

6 1/2 [165mm]

14 [354mm] Minimum

4 [102mm] wide x 16' (406 mm) long cutout in Vent Cowl/Splash Shield. Shipped with Cover Plate.

64 [1626mm] Table to Table

72 [1826mm] Overall

80 [2032mm] Overall

21 [535mm]

8 [204mm] Scrap Trough

14 [355mm] Minimum

25 [637mm]

4" (102 mm) wide x 16' (406 mm) long cutout in Vent Cowl/Splash Shield. Shipped with Cover Plate.

64 [1626mm] Table to Table

72 [1826mm] Overall

80 [2032mm] Overall

21 [535mm]

8 [204mm] Scrap Trough

14 [355mm] Minimum

25 [637mm]

4" (102 mm) wide x 16' (406 mm) long cutout in Vent Cowl/Splash Shield. Shipped with Cover Plate.

64 [1626mm] Table to Table

72 [1826mm] Overall

80 [2032mm] Overall

21 [535mm]

8 [204mm] Scrap Trough

14 [355mm] Minimum

25 [637mm]

4" (102 mm) wide x 16' (406 mm) long cutout in Vent Cowl/Splash Shield. Shipped with Cover Plate.

64 [1626mm] Table to Table

72 [1826mm] Overall

80 [2032mm] Overall

21 [535mm]

8 [204mm] Scrap Trough

14 [355mm] Minimum

25 [637mm]

4" (102 mm) wide x 16' (406 mm) long cutout in Vent Cowl/Splash Shield. Shipped with Cover Plate.

64 [1626mm] Table to Table

72 [1826mm] Overall

80 [2032mm] Overall

21 [535mm]

8 [204mm] Scrap Trough

14 [355mm] Minimum

25 [637mm]

4" (102 mm) wide x 16' (406 mm) long cutout in Vent Cowl/Splash Shield. Shipped with Cover Plate.

64 [1626mm] Table to Table

72 [1826mm] Overall

80 [2032mm] Overall

21 [535mm]

8 [204mm] Scrap Trough

14 [355mm] Minimum

25 [637mm]

4" (102 mm) wide x 16' (406 mm) long cutout in Vent Cowl/Splash Shield. Shipped with Cover Plate.

64 [1626mm] Table to Table

72 [1826mm] Overall

80 [2032mm] Overall

21 [535mm]

8 [204mm] Scrap Trough

14 [355mm] Minimum

25 [637mm]

4" (102 mm) wide x 16' (406 mm) long cutout in Vent Cowl/Splash Shield. Shipped with Cover Plate.

64 [1626mm] Table to Table

72 [1826mm] Overall

80 [2032mm] Overall

21 [535mm]

8 [204mm] Scrap Trough

14 [355mm] Minimum

25 [637mm]

4" (102 mm) wide x 16' (406 mm) long cutout in Vent Cowl/Splash Shield. Shipped with Cover Plate.

64 [1626mm] Table to Table

72 [1826mm] Overall

80 [2032mm] Overall

21 [535mm]

8 [204mm] Scrap Trough

14 [355mm] Minimum

25 [637mm]

4" (102 mm) wide x 16' (406 mm) long cutout in Vent Cowl/Splash Shield. Shipped with Cover Plate.

64 [1626mm] Table to Table

72 [1826mm] Overall

80 [2032mm] Overall

21 [535mm]

8 [204mm] Scrap Trough

14 [355mm] Minimum

25 [637mm]

4" (102 mm) wide x 16' (406 mm) long cutout in Vent Cowl/Splash Shield. Shipped with Cover Plate.

64 [1626mm] Table to Table

72 [1826mm] Overall

80 [2032mm] Overall

21 [535mm]

8 [204mm] Scrap Trough

14 [355mm] Minimum

25 [637mm]

4" (102 mm) wide x 16' (406 mm) long cutout in Vent Cowl/Splash Shield. Shipped with Cover Plate.

64 [1626mm] Table to Table

72 [1826mm] Overall

80 [2032mm] Overall

21 [535mm]

8 [204mm] Scrap Trough

14 [355mm] Minimum

25 [637mm]

4" (102 mm) wide x 16' (406 mm) long cutout in Vent Cowl/Splash Shield. Shipped with Cover Plate.

64 [1626mm] Table to Table

72 [1826mm] Overall

80 [2032mm] Overall

21 [535mm]

8 [204mm] Scrap Trough

14 [355mm] Minimum

25 [637mm]

4" (102 mm) wide x 16' (406 mm) long cutout in Vent Cowl/Splash Shield. Shipped with Cover Plate.

64 [1626mm] Table to Table

72 [1826mm] Overall

80 [2032mm] Overall

21 [535mm]

8 [204mm] Scrap Trough

14 [355mm] Minimum

25 [637mm]

4" (102 mm) wide x 16' (406 mm) long cutout in Vent Cowl/Splash Shield. Shipped with Cover Plate.

64 [1626mm] Table to Table

72 [1826mm] Overall

80 [2032mm] Overall

21 [535mm]

8 [204mm] Scrap Trough

14 [355mm] Minimum

25 [637mm]

4" (102 mm) wide x 16' (406 mm) long cutout in Vent Cowl/Splash Shield. Shipped with Cover Plate.

64 [1626mm] Table to Table

72 [1826mm] Overall

80 [2032mm] Overall

21 [535mm]

8 [204mm] Scrap Trough

14 [355mm] Minimum

25 [637mm]

4" (102 mm) wide x 16' (406 mm) long cutout in Vent Cowl/Splash Shield. Shipped with Cover Plate.

64 [1626mm] Table to Table

72 [1826mm] Overall

80 [2032mm] Overall

21 [535mm]

8 [204mm] Scrap Trough

14 [355mm] Minimum

25 [637mm]

4" (102 mm) wide x 16' (406 mm) long cutout in Vent Cowl/Splash Shield. Shipped with Cover Plate.

64 [1626mm] Table to Table

72 [1826mm] Overall

80 [2032mm] Overall

21 [535mm]

8 [204mm] Scrap Trough

14 [355mm] Minimum

25 [637mm]

4" (102 mm) wide x 16' (406 mm) long cutout in Vent Cowl/Splash Shield. Shipped with Cover Plate.

64 [1626mm] Table to Table

72 [1826mm] Overall

80 [2032mm] Overall

21 [535mm]

8 [204mm] Scrap Trough

14 [355mm] Minimum

25 [637mm]

4" (102 mm) wide x 16' (406 mm) long cutout in Vent Cowl/Splash Shield. Shipped with Cover Plate.

64 [1626mm] Table to Table

72 [1826mm] Overall

80 [2032mm] Overall

21 [535mm]

8 [204mm] Scrap Trough

14 [355mm] Minimum

25 [637mm]

4" (102 mm) wide x 16' (406 mm) long cutout in Vent Cowl/Splash Shield. Shipped with Cover Plate.

64 [1626mm] Table to Table

72 [1826mm] Overall

80 [2032mm] Overall

21 [535mm]

8 [204mm] Scrap Trough

14 [355mm] Minimum

25 [637mm]

4" (102 mm) wide x 16' (406 mm) long cutout in Vent Cowl/Splash Shield. Shipped with Cover Plate.

64 [1626mm] Table to Table

72 [1826mm] Overall

80 [2032mm] Overall

21 [535mm]

8 [204mm] Scrap Trough

14 [355mm] Minimum

25 [637mm]

4" (102 mm) wide x 16' (406 mm) long cutout in Vent Cowl/Splash Shield. Shipped with Cover Plate.

64 [1626mm] Table to Table

72 [1826mm] Overall

80 [2032mm] Overall

21 [535mm]

8 [204mm] Scrap Trough

14 [355mm] Minimum

25 [637mm]

4" (102 mm) wide x 16' (406 mm) long cutout in Vent Cowl/Splash Shield. Shipped with Cover Plate.

64 [1626mm] Table to Table

72 [1826mm] Overall

80 [2032mm] Overall

21 [535mm]

8 [204mm] Scrap Trough

SECTION 1: SPECIFICATION INFORMATION

AJ-64 GAS - RIGHT TO LEFT

Right to Left

Legend to Drawing

- A - Machine water inlet 3/4" NPT, 110°F - 140°F Hi-temp, 140°F Low-temp minimum
- B - Electrical connection
- C - Drain connection 1-1/2" NPT
- D - Vent collar - Optional
- E - Vent cowi standard
- F - 3/4" NPT 180°F Water Inlet for wash tank fill, final rinse, & tank heating. From gas booster heater. Interconnecting hose provided by manufacturer.
- G - 3/4" NPT 140°F Water inlet for gas booster heater.
- H - 3/4" NPT 180°F Water Outlet connection to line on dishmachine. Connection hose provided by manufacturer.
- J - 3/4" NPT Gas Connection
- K - 4" OD Vent pipe connection. Flue to be installed to meet local codes by installing contractor.

Recommended Table Fabrication

Note: Tub Will Accept a Table Flange Up to 24 7/8" (632 mm)

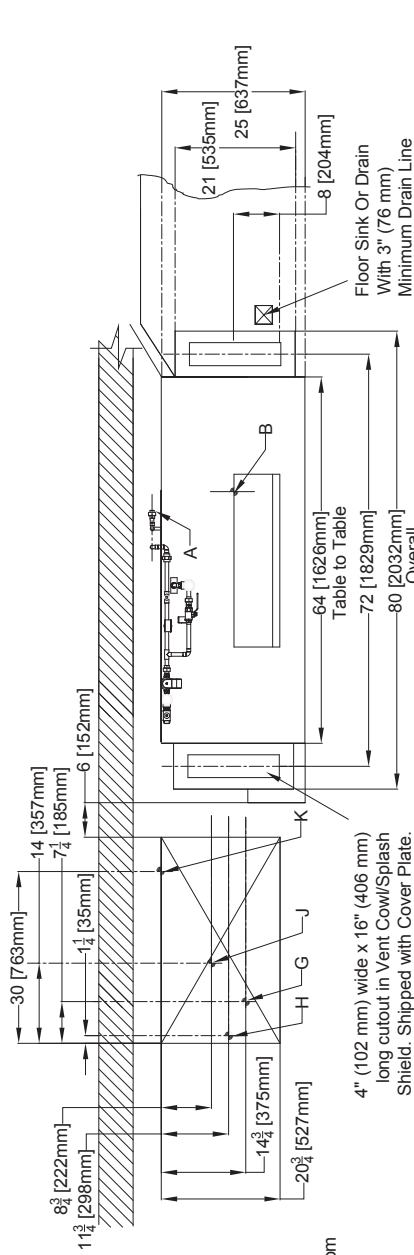
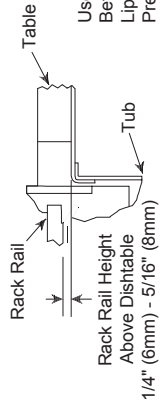

Note: All vertical dimensions are +/- 1/2" from floor due to adjustable bullet feet.

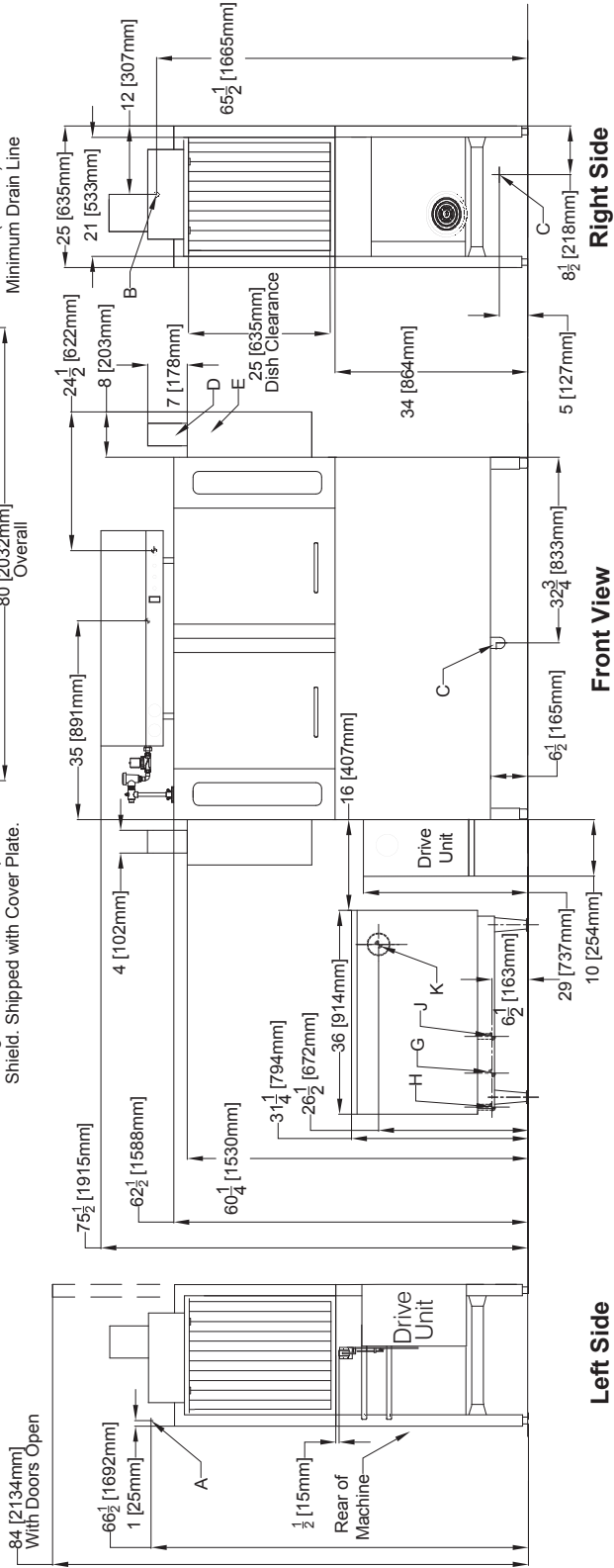

Left Side

Front View

Right Side

SECTION 1: SPECIFICATION INFORMATION

AJ-64 STEAM - RIGHT TO LEFT

Right to Left

Legend

- A - Machine water inlet 3/4" NPT 180°F Hi-temp, 140°F Low-temp minimum
- B - Electrical connection
- C - Drain connection 1-1/2" NPT
- D - Vent collar - Optional
- E - Vent cowli standard
- F - 3/4" NPT Steam connection
- G - 3/4" NPT Condensate return
- H - Steam electrical connection
- J - 1" NPT Steam connection
- K - 3/4" Condensate connection
- L - 3/4" NPT Incoming 110°F water connection
- M - 3/4" NPT 180°F water to dishmachine.

Note: All vertical dimensions are +/- 1/2" from floor due to adjustable bullet feet.

Recommended Table Fabrication

Note: Tub Will Accept a Table Flange Up to 24 7/8" (632 mm)

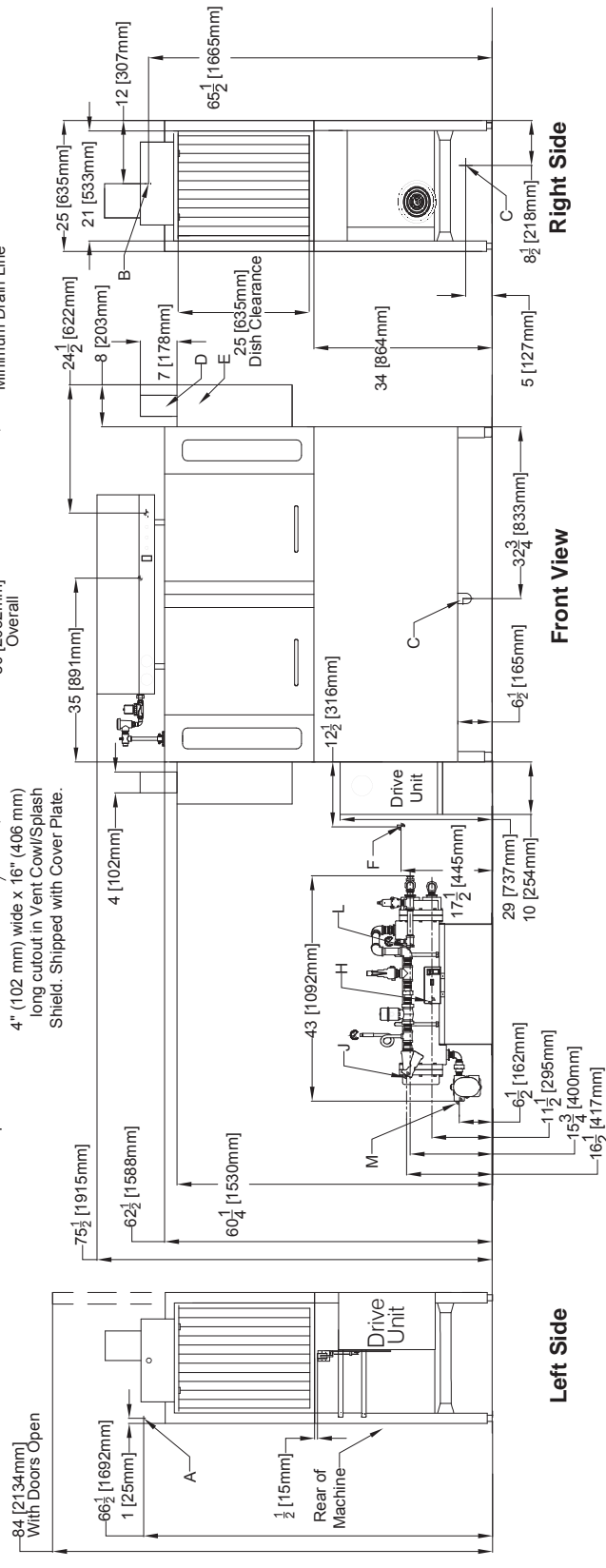
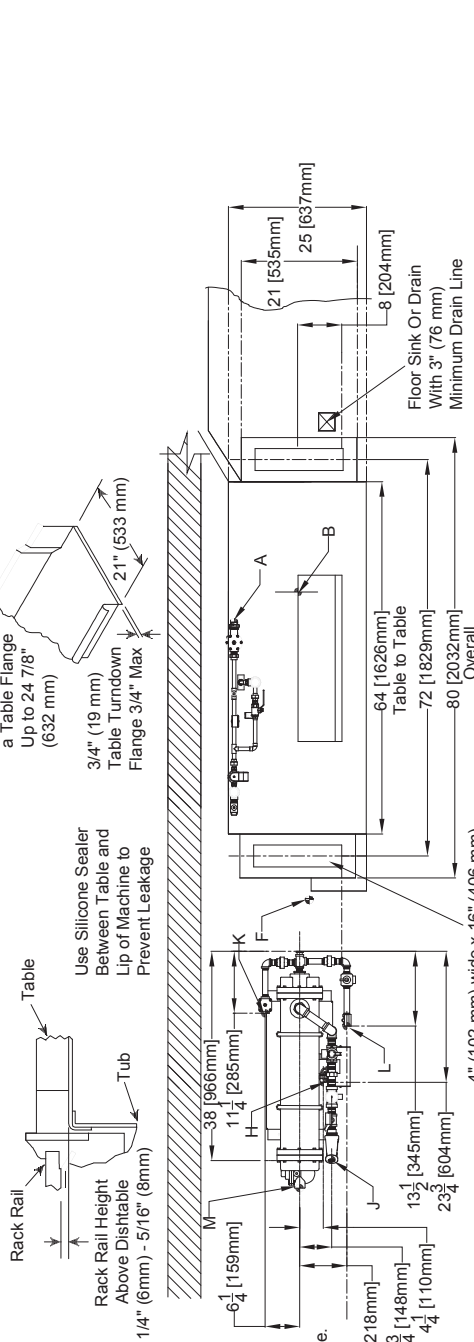

SECTION 1: SPECIFICATION INFORMATION

AJ-86 ELECTRIC - LEFT TO RIGHT

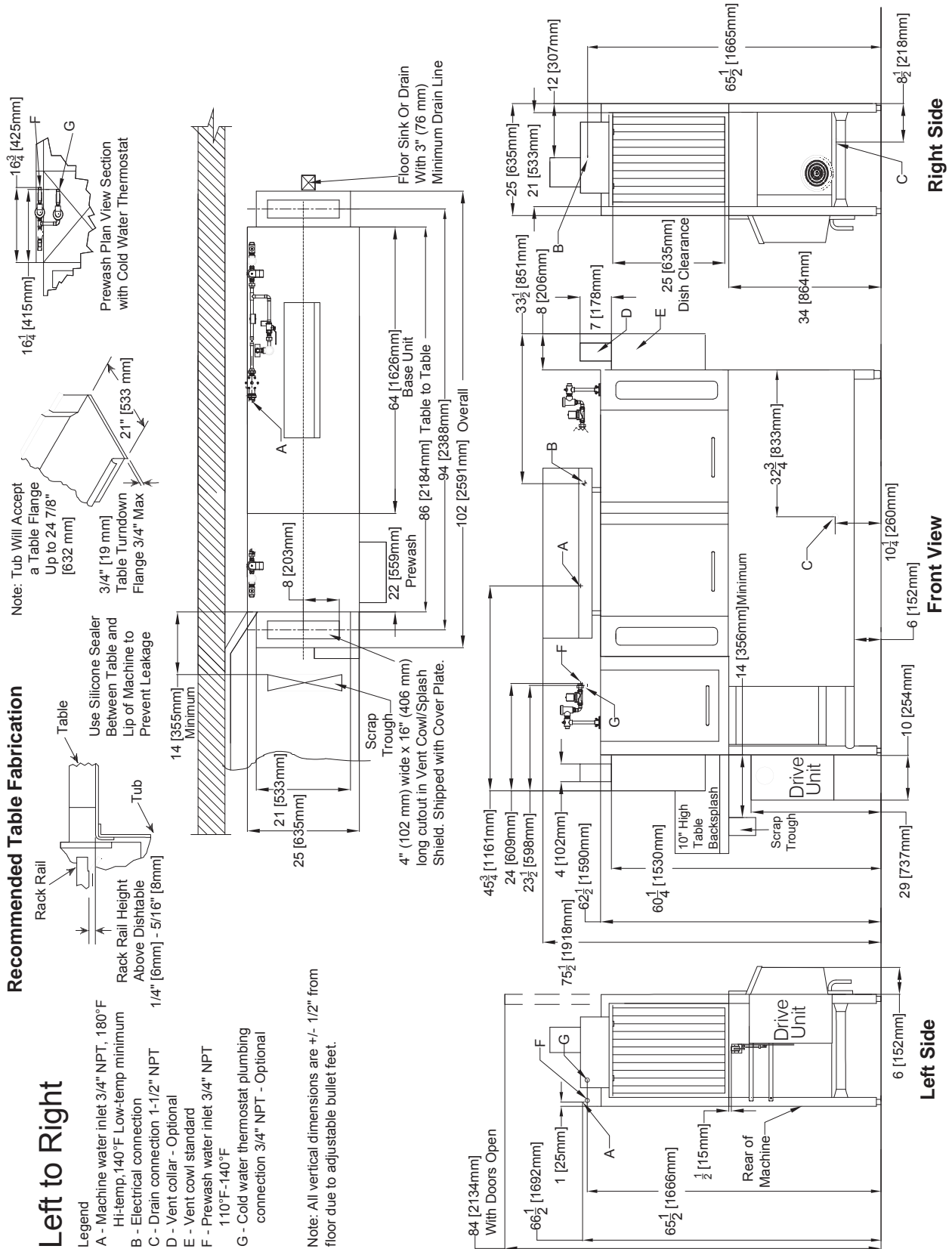

SECTION 1: SPECIFICATION INFORMATION

AJ-86 GAS - LEFT TO RIGHT

Left to Right

Legend

- A - Machine water inlet 3/4" NPT, 110°F - 140°F Hi-temp, 140°F Low-temp minimum
- B - Electrical connection
- C - Drain connection 1-1/2" NPT
- D - Vent collar - Optional
- E - Vent cowl standard
- F - 3/4" NPT 180°F Water Inlet for wash tank fill, final rinse, & tank heating. From gas booster heater. Interconnecting hose provided by manufacturer.
- G - 3/4" NPT 140°F Water inlet for gas booster heater.
- H - 3/4" NPT 180°F Water Outlet connection to line on dishmachine. Connection hose provided by manufacturer.
- J - 3/4" NPT Gas Connection
- K - 4" OD Vent pipe connection. Flue to be installed to meet local codes by installing contractor.
- L - Prewash water inlet 3/4" NPT 110°F-140°F
- M - Cold water thermostat plumbing connection 3/4" NPT - Optional

Note: All vertical dimensions are +/- 1/2" from floor due to adjustable bullet feet.

Recommended Table Fabrication

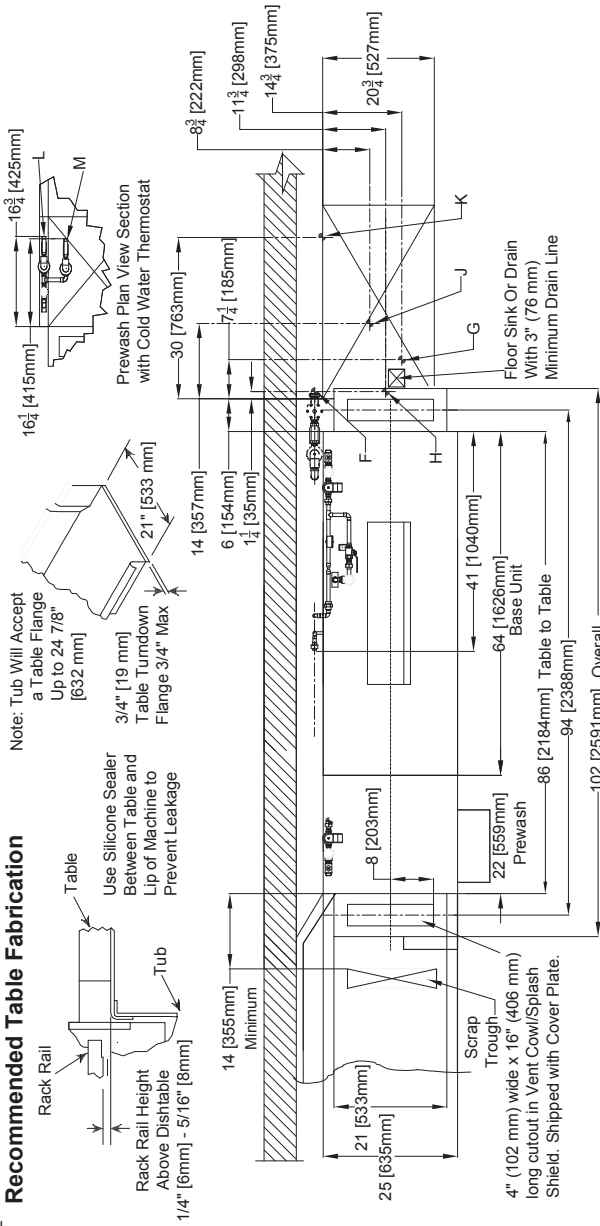

Note: Tub Will Accept a Table Flange Up to 24 7/8" [632 mm]

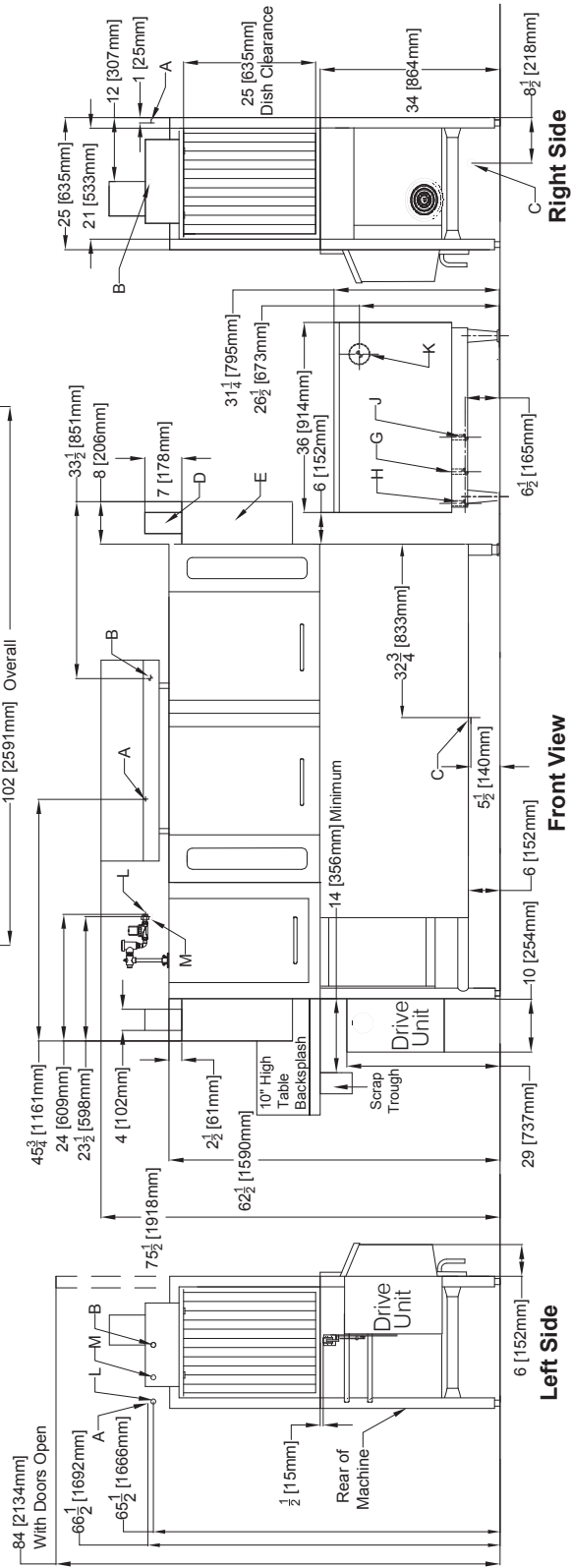
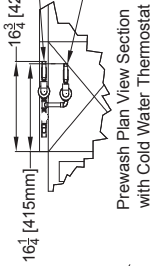

SECTION 1: SPECIFICATION INFORMATION

AJ-86 GAS - LEFT TO RIGHT

Left to Right

Legend

- A - Machine water inlet 3/4" NPT, 180°F Hi-temp, 140°F Low-temp minimum
- B - Electrical connection
- C - Drain connection 1-1/2" NPT
- D - Vent collar - Optional
- E - Vent cowl standard
- F - 3/4" NPT 180°F Water Inlet for wash tank fill, final rinse, & tank heating. From gas booster heater. Interconnecting hose provided by manufacturer.
- G - 3/4" NPT 140°F Water inlet for gas booster heater.
- H - 3/4" NPT 180°F Water Outlet connection to line on dishmachine. Connection hose provided by manufacturer.
- J - 3/4" NPT Gas Connection
- K - 4" OD Vent pipe connection. Flue to be installed to meet local codes by installing contractor.
- L - Prewash water inlet 3/4" NPT 110°F-140°F
- M - Cold water thermostat plumbing connection 3/4" NPT - Optional

Recommended Table Fabrication

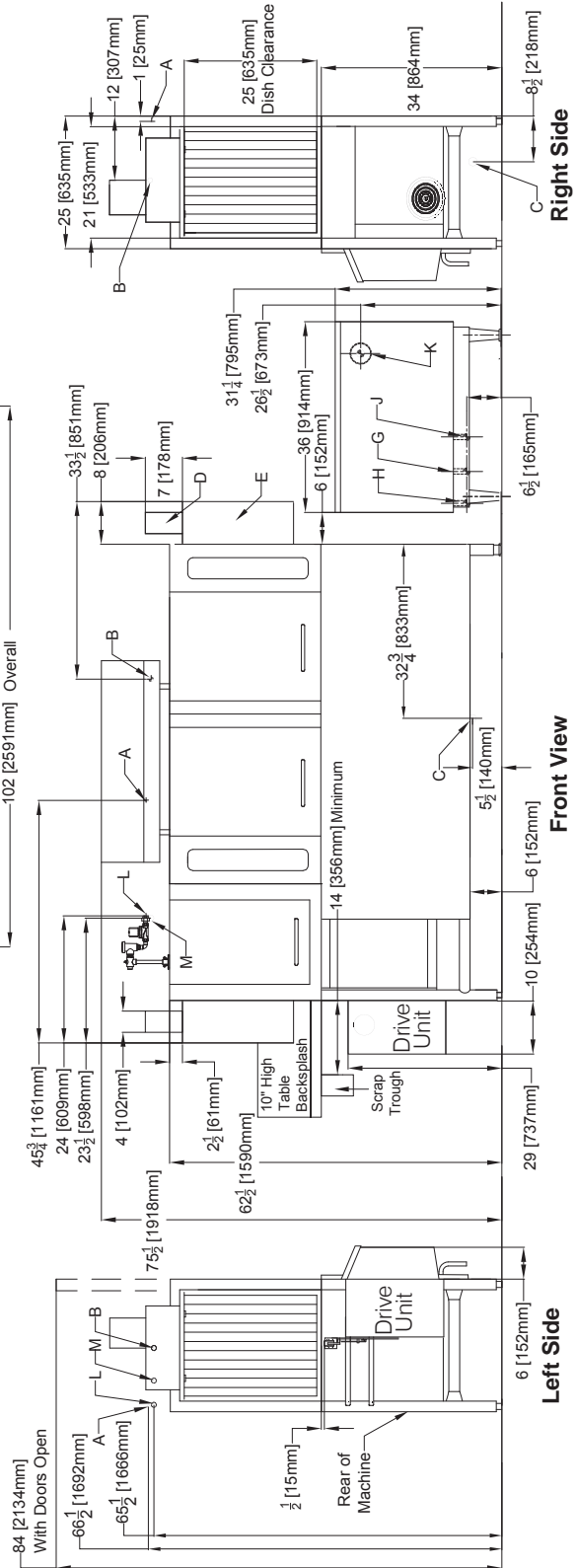
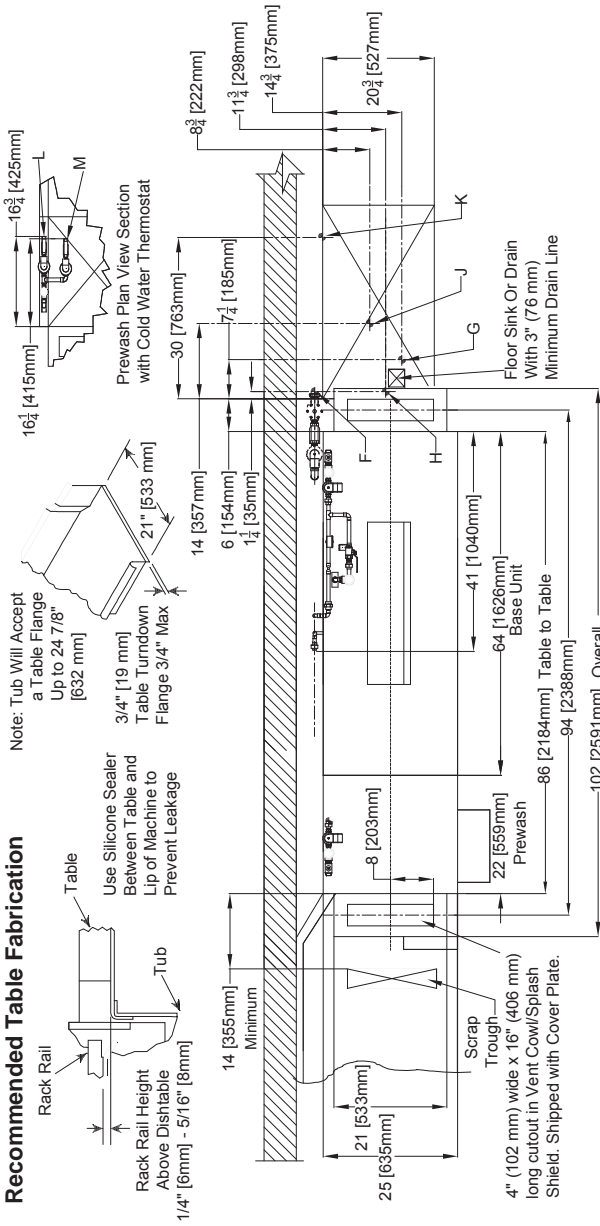

SECTION 1: SPECIFICATION INFORMATION

AJ-86 GAS - RIGHT TO LEFT

Right to Left

- Legend to Drawing
 A - Machine water inlet 3/4" NPT, 110°F - 140°F
 B - Hi-temp, 140°F Low-temp minimum
 C - Electrical connection
 D - Drain connection 1-1/2" NPT
 E - Vent collar - Optional
 F - Vent cowli standard
 G - 3/4" NPT 180°F Water inlet for wash tank fill, final rinse, & tank heating. From gas booster heater. Interconnecting hose provided by manufacturer.
 H - 3/4" NPT 140°F Water inlet for gas booster heater.
 I - 3/4" NPT 180°F Water Outlet connection to line on dishmachine. Connection hose provided by manufacturer.
 J - 3/4" NPT Gas Connection
 K - 4" OD Vent pipe connection. Flue to be installed to meet local codes by installing contractor.
 L - Prewash water inlet 3/4" NPT 110°F - 140°F
 M - Cold water thermostat plumbing connection 3/4" NPT - Optional

Recommended Table Fabrication

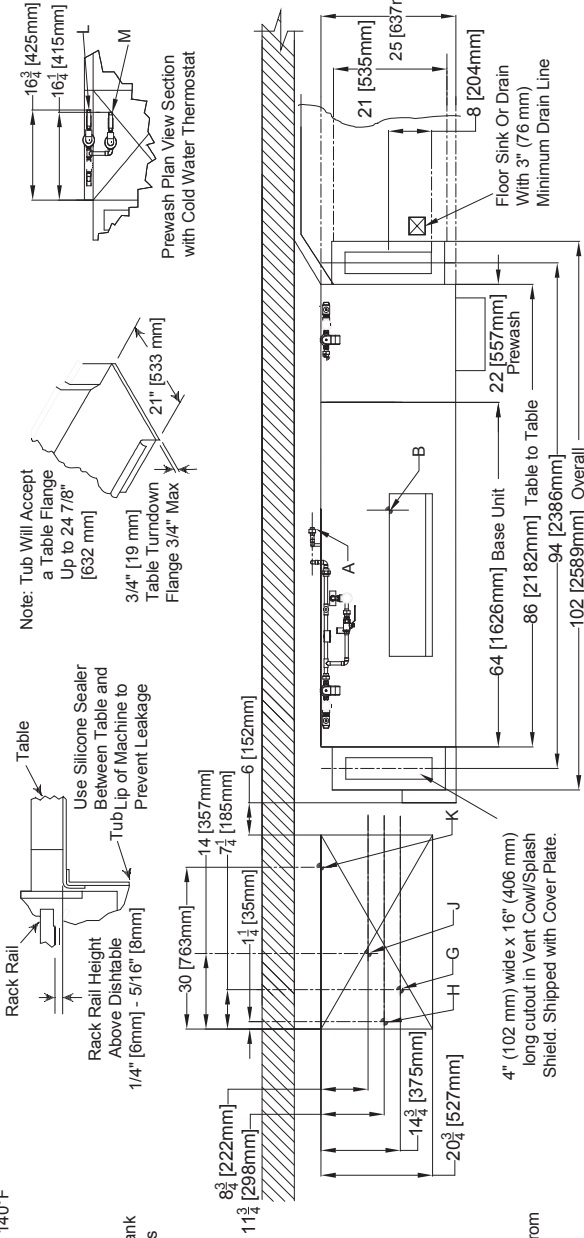

Note: All vertical dimensions are +/- 1/2" from floor due to adjustable bullet feet.

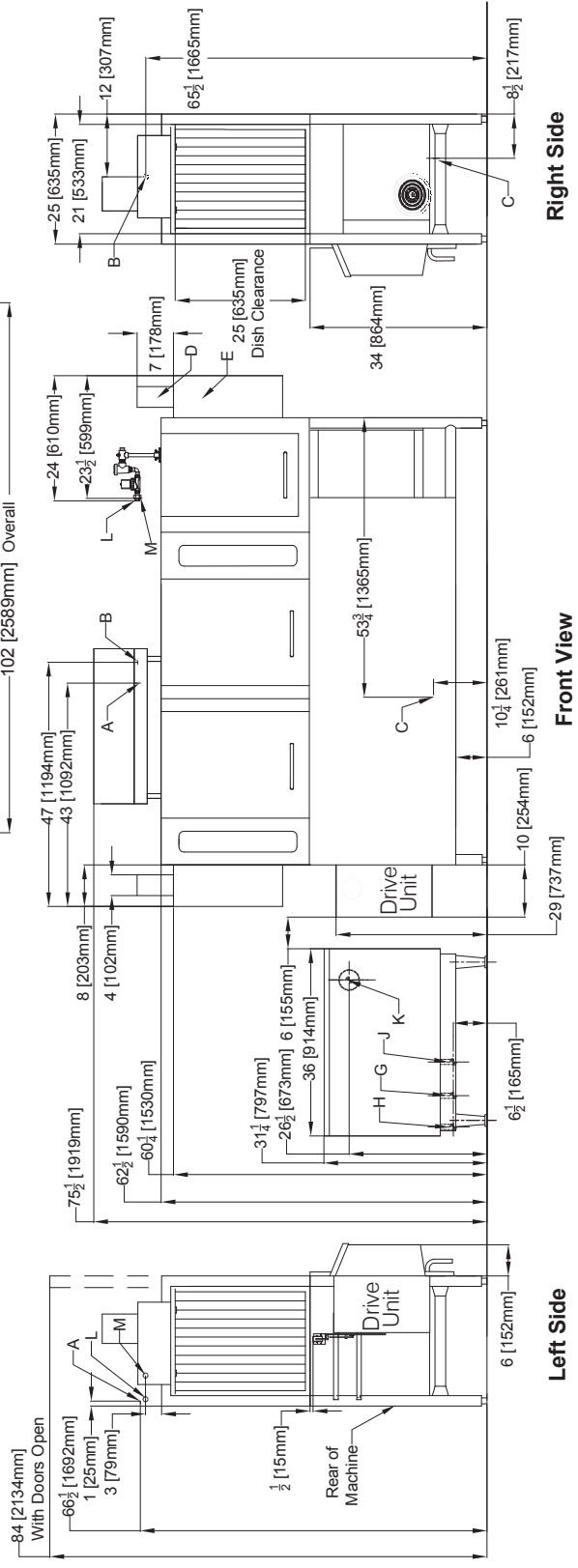

SECTION 1: SPECIFICATION INFORMATION

AJ-86 STEAM - RIGHT TO LEFT

Right to Left

- Legend**
- A - Machine water inlet 3/4" NPT 180°F
 - Hi-temp, 140°F Low-temp minimum
 - B - Electrical connection
 - C - Drain connection 1-1/2" NPT
 - D - Vent collar - Optional
 - E - Vent cowl standard
 - F - 3/4" NPT Steam connection
 - G - 3/4" NPT Condensate return
 - H - Steam electrical connection
 - J - 1" NPT Steam connection
 - K - 3/4" Condensate connection
 - L - 3/4" NPT Incoming 110°F water connection
 - M - 3/4" NPT 180°F water to dishmachine.
 - N - Prewash water inlet 3/4" NPT 110°F-140°F
 - O - Cold water thermostat plumbing connection 3/4" NPT - Optional

Note: All vertical dimensions are +/- 1/2" from floor due to adjustable bullet feet.

Recommended Table Fabrication

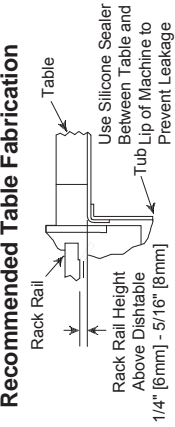

Note: Tub Will Accept a Table Flange Up to 24 7/8" [632 mm]

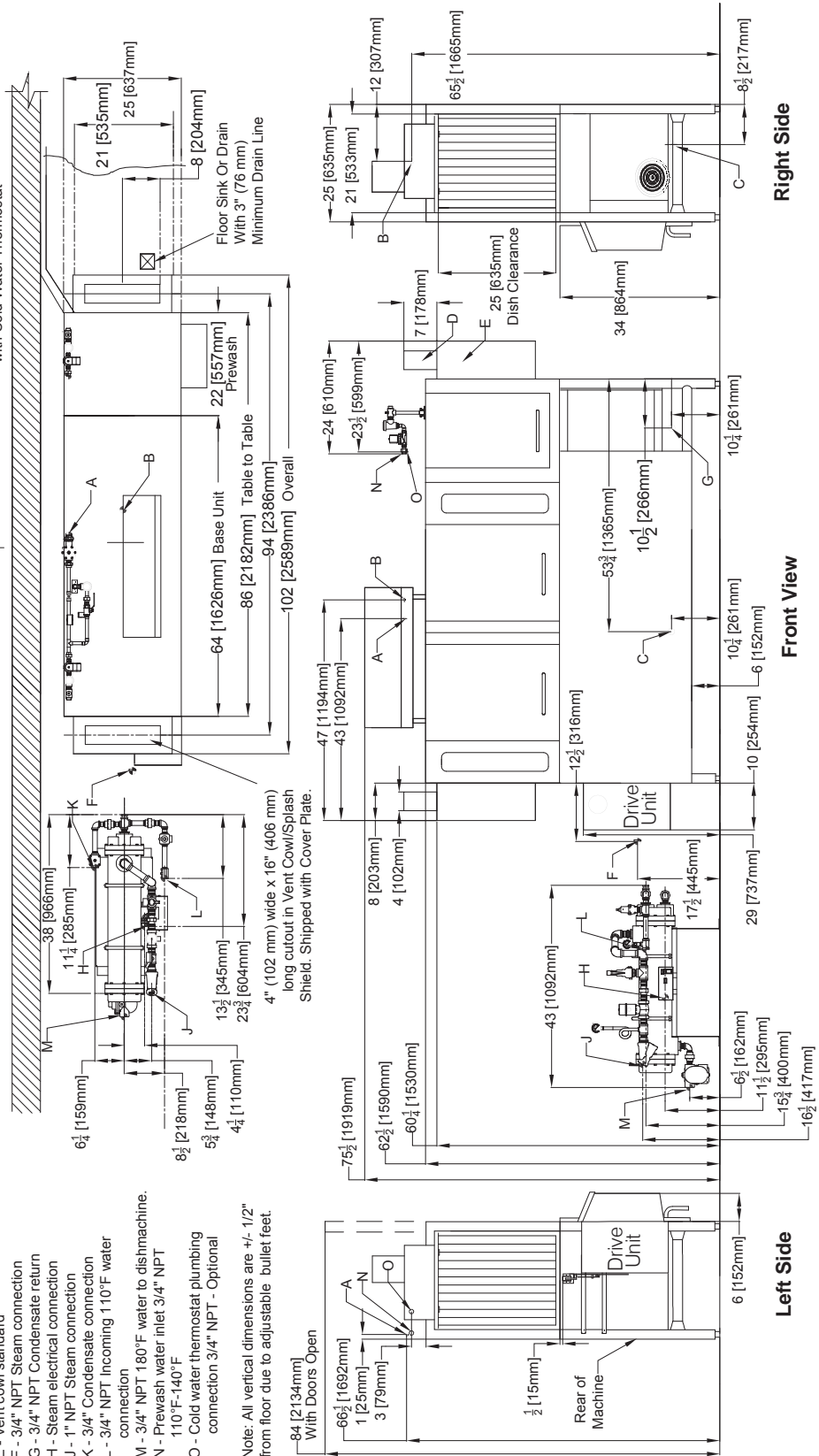
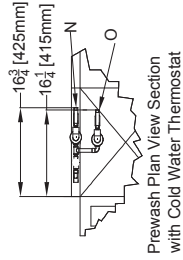
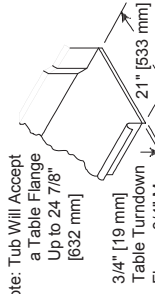

SECTION 1: SPECIFICATION INFORMATION

AJ-100 ELECTRIC - LEFT TO RIGHT

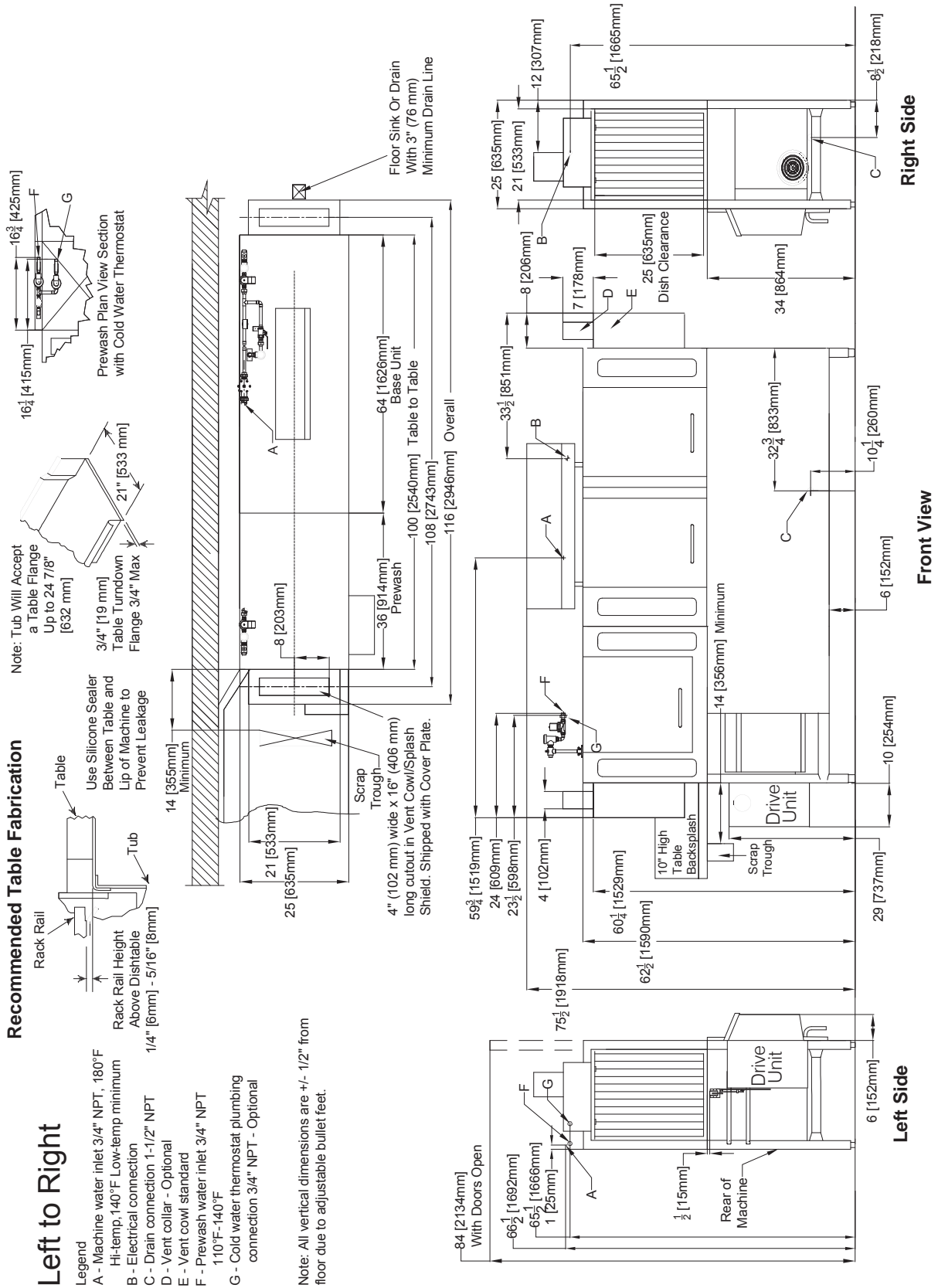

SECTION 1: SPECIFICATION INFORMATION

AJ-100 GAS - RIGHT TO LEFT

Right to Left

- Legend to Drawing
 A - Machine water inlet 3/4" NPT, 110°F - 140°F
 HI-temp, 140°F Low-temp minimum
 B - Electrical connection
 C - Drain connection 1-1/2" NPT
 D - Vent collar - Optional
 E - Vent cowl standard
 F - 3/4" NPT 180°F Water Inlet for wash tank fill, final rinse, & tank heating. From gas booster heater. Interconnecting hose provided by manufacturer.
 G - 3/4" NPT 140°F Water inlet for gas booster heater.
 H - 3/4" NPT 180°F Water Outlet connection to line on dishmachine. Connection hose provided by manufacturer.
 J - 3/4" NPT Gas Connection
 K - 4" OD Vent pipe connection. Flue to be installed to meet local codes by installing contractor.
 L - Prewash water inlet 3/4" NPT 110°F-140°F
 M - Cold water thermostat plumbing connection 3/4" NPT - Optional

Recommended Table Fabrication

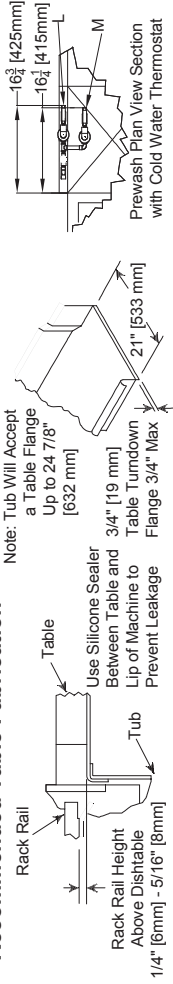

Note: Tub Will Accept a Table Flange Up to 24 7/8" [632 mm]

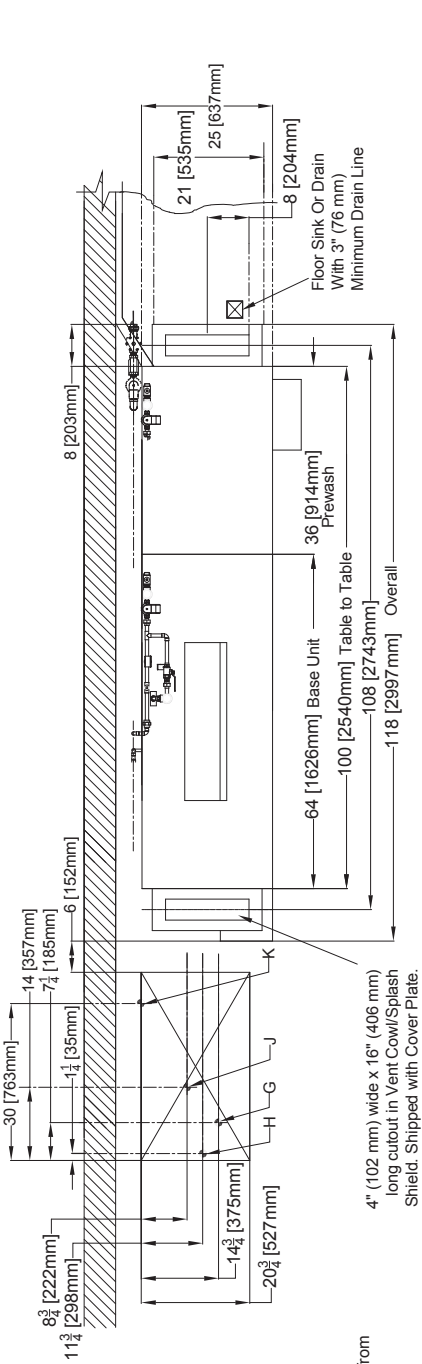
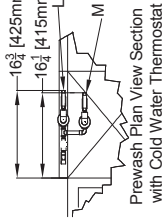

Note: All vertical dimensions are +/- 1/2" from floor due to adjustable bullet feet

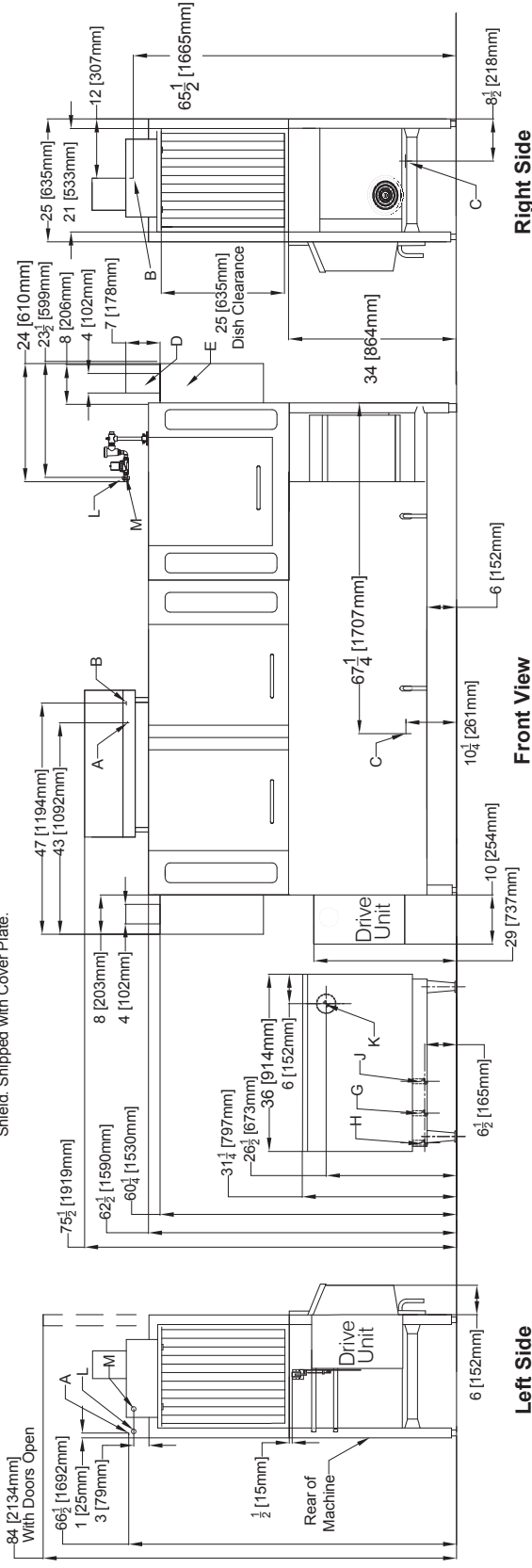

SECTION 1: SPECIFICATION INFORMATION

AJ-100 STEAM - LEFT TO RIGHT

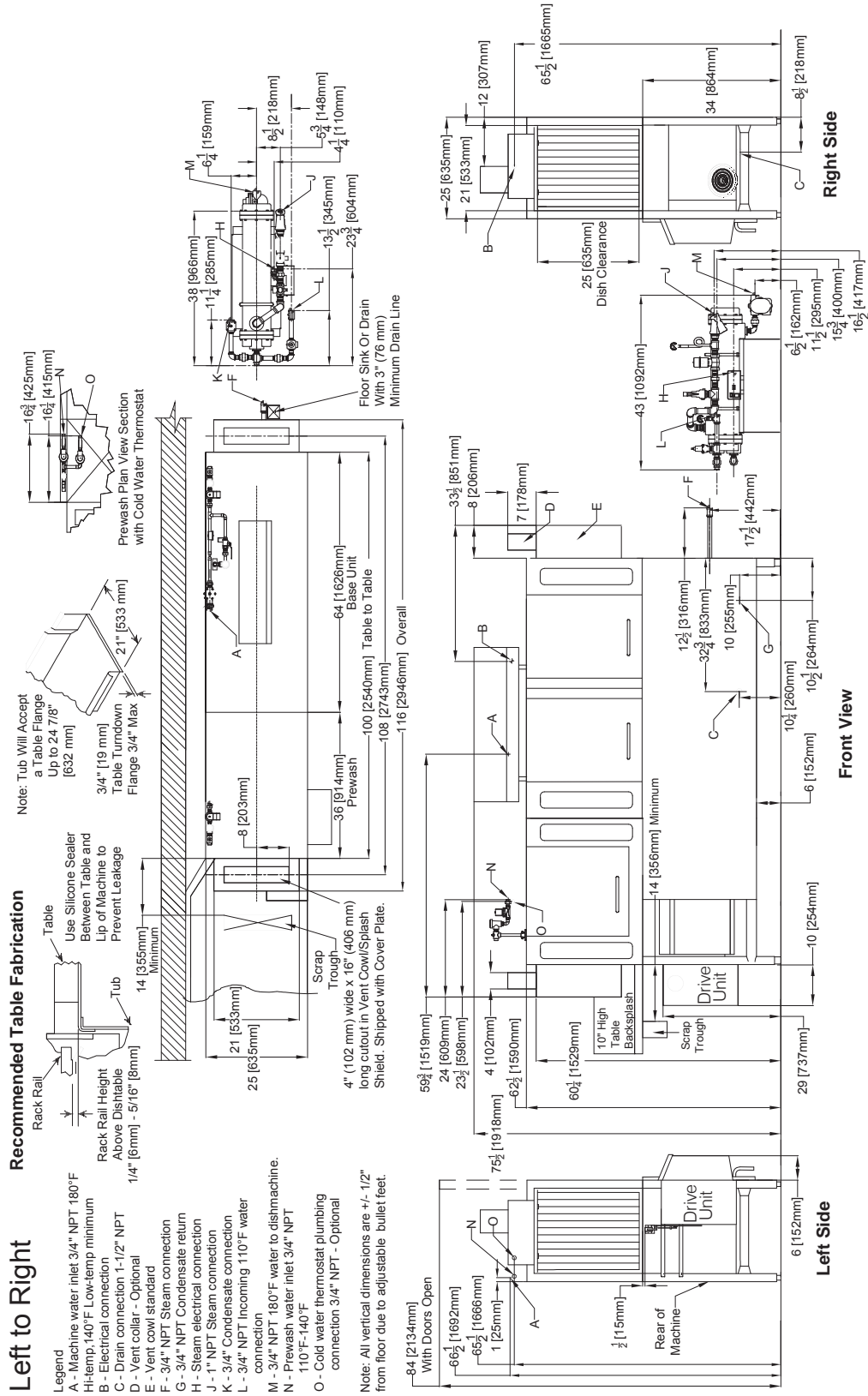

SECTION 1: SPECIFICATION INFORMATION

AJ-100 STEAM - RIGHT TO LEFT

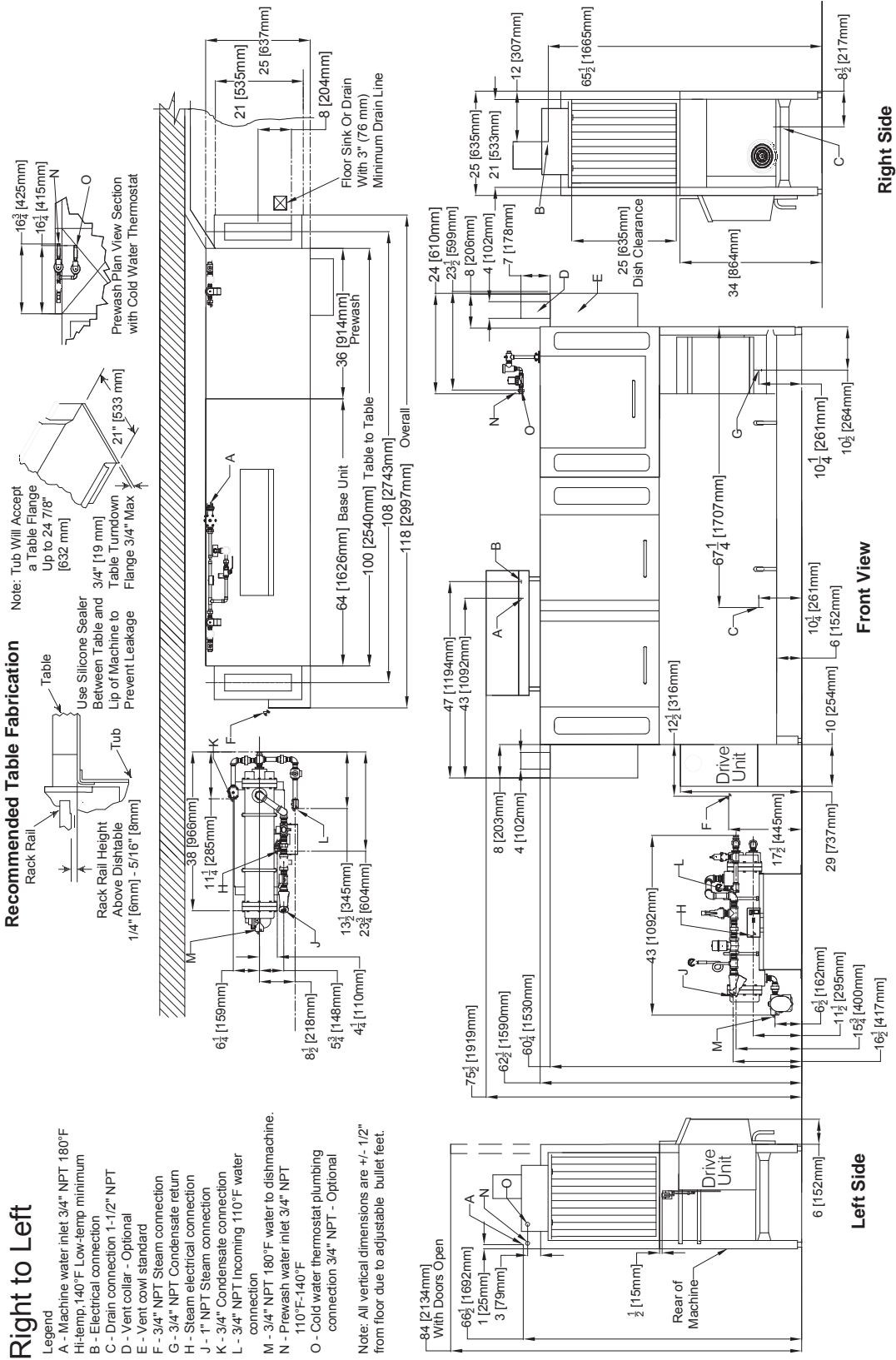

SECTION 1: SPECIFICATION INFORMATION

SIDE LOADER (LEFT TO RIGHT) DIMENSIONS

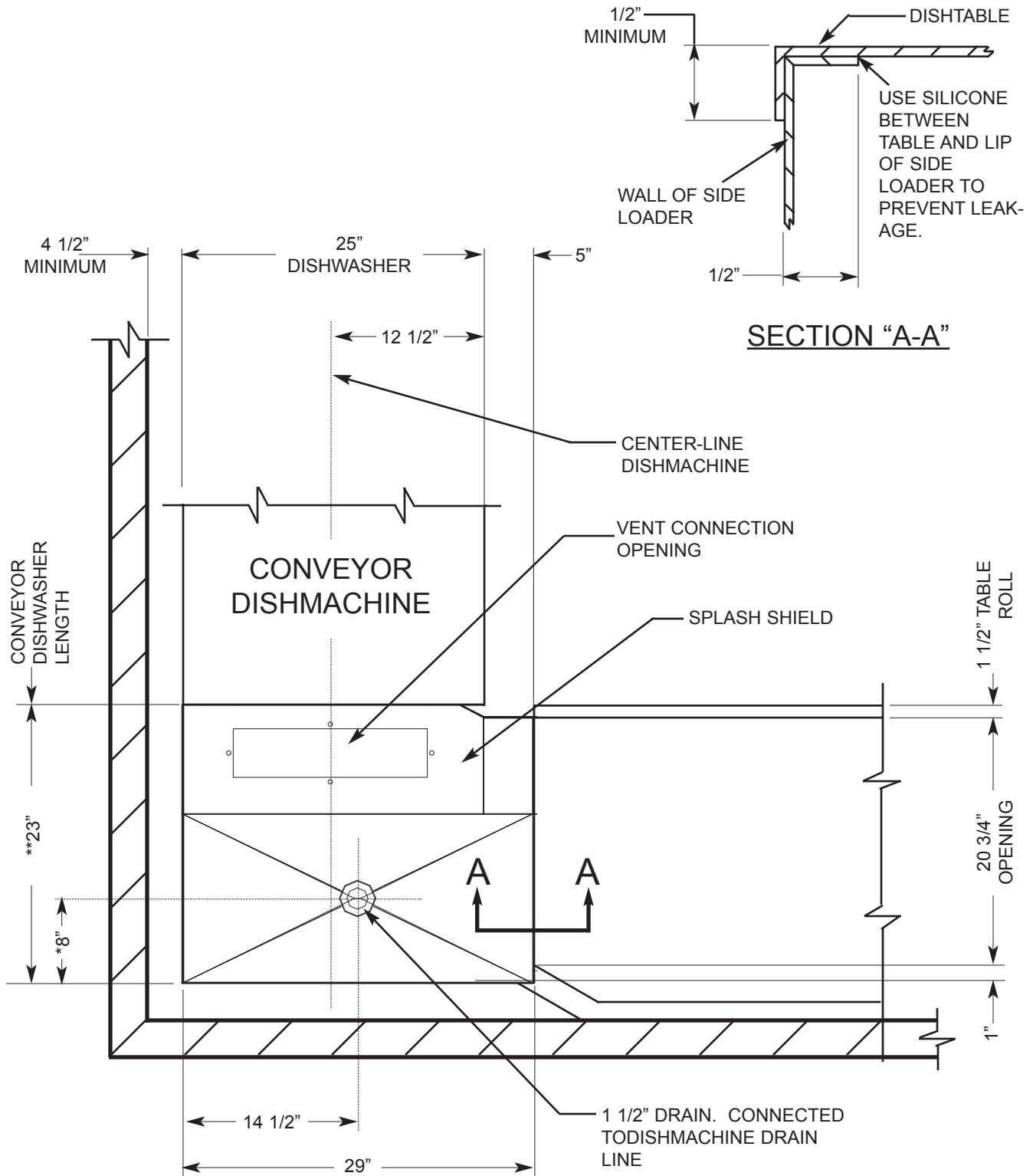

* - 15" for 30" Model

** - 30" for 30" Model

SECTION 1: SPECIFICATION INFORMATION

SIDE LOADER (RIGHT TO LEFT) DIMENSIONS

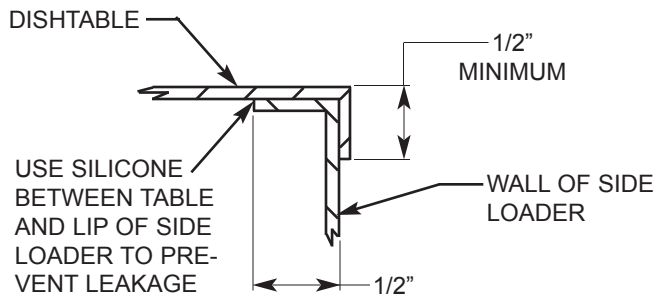

SECTION "A-A"

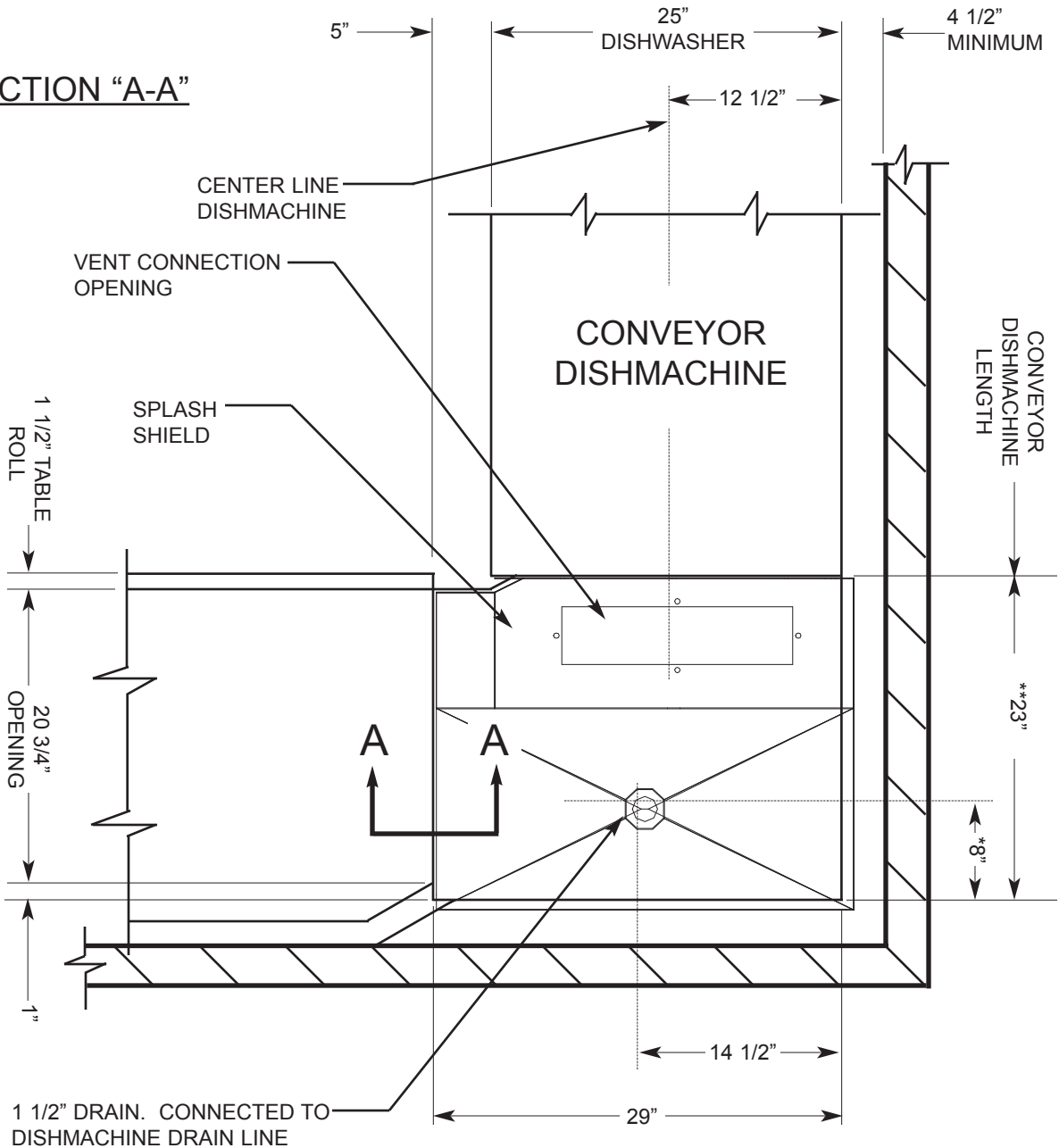

* - 15" for 30" Model

** - 30" for 30" Model

SECTION 1: SPECIFICATION INFORMATION

SIDE LOADER INSTALLATION DIMENSIONS

23" SIDE LOADER DIMENSIONS

<u>MODEL</u>	<u>DIMENSIONS</u>
AJ-64	95"
AJ-86	117"
AJ-100	131"

30" SIDE LOADER DIMENSIONS

<u>MODEL</u>	<u>DIMENSIONS</u>
AJ-64	102"
AJ-86	124"
AJ-100	138"

NOTE: ALL DIMENSIONS ARE TYPICAL.

(Left to Right installation shown for reference.)

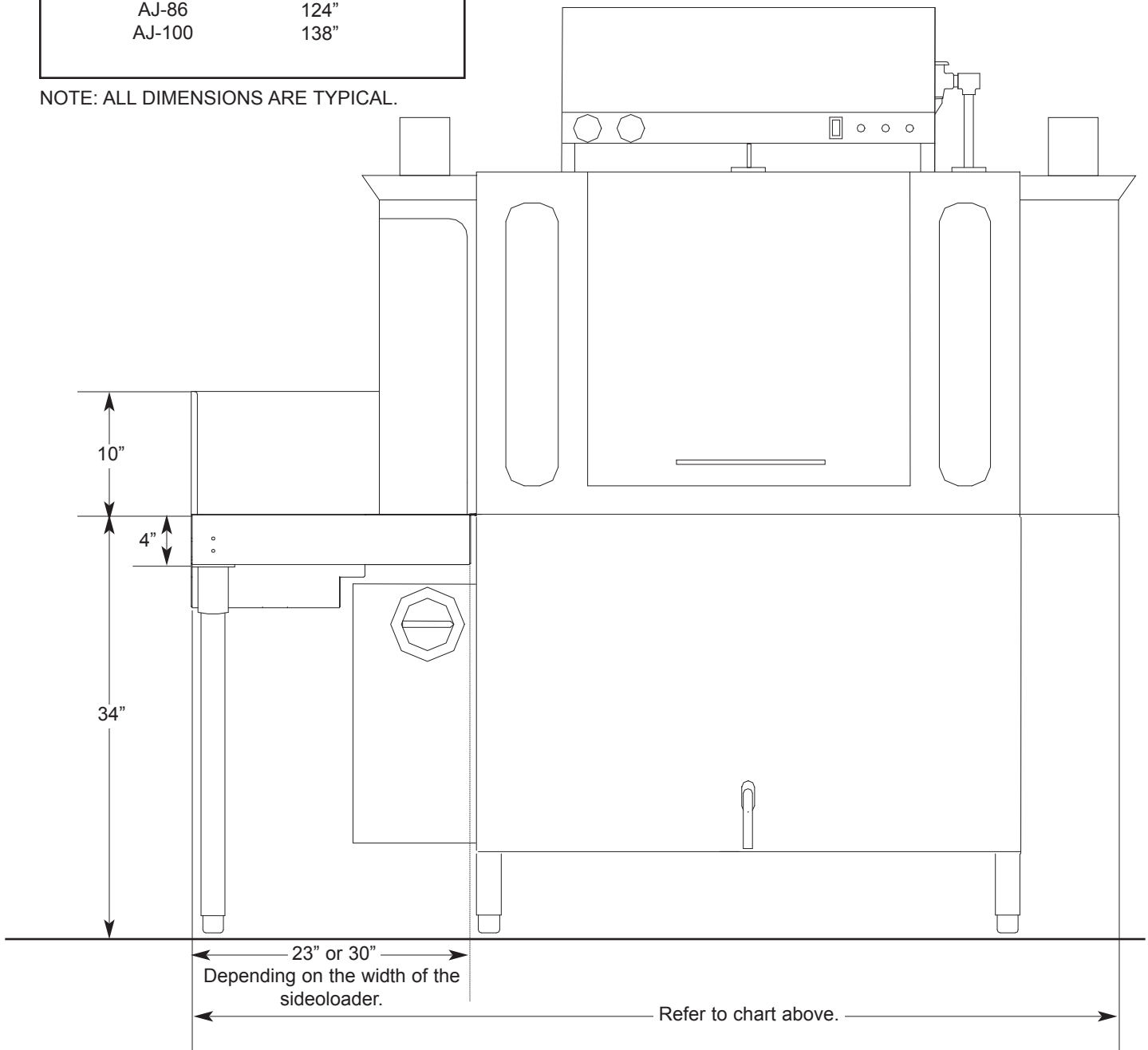

SECTION 1: SPECIFICATION INFORMATION
D226 STEAM BOOSTER DIMENSIONS

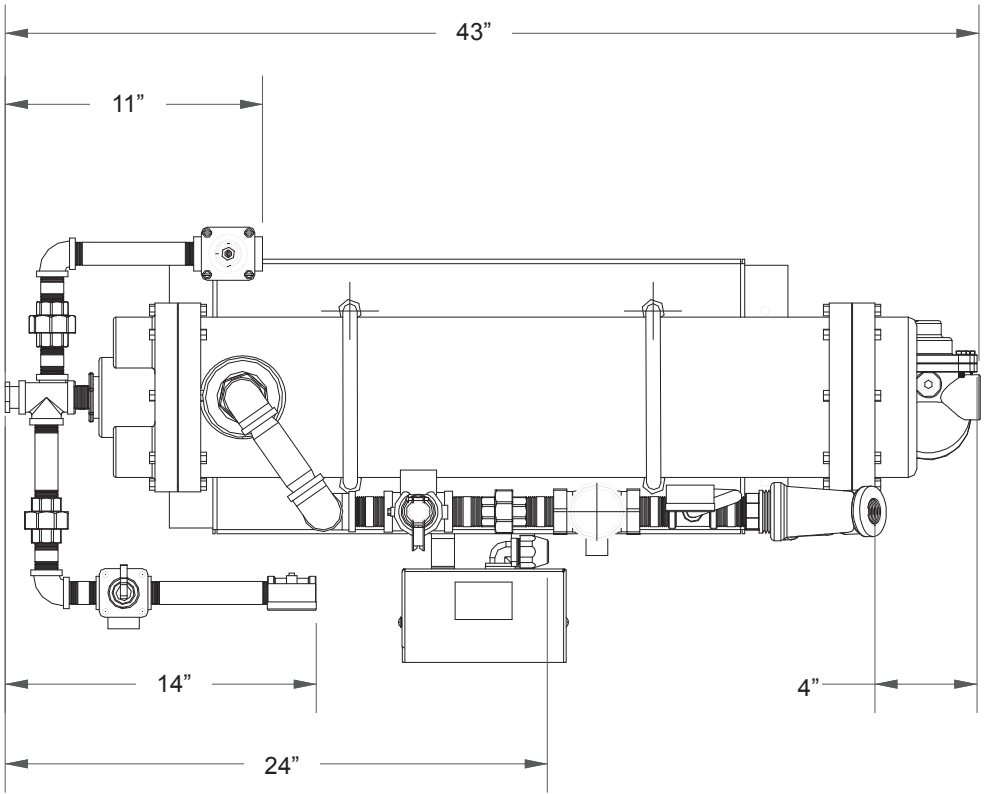

NOTE: All dimensions are in inches and are for reference only.

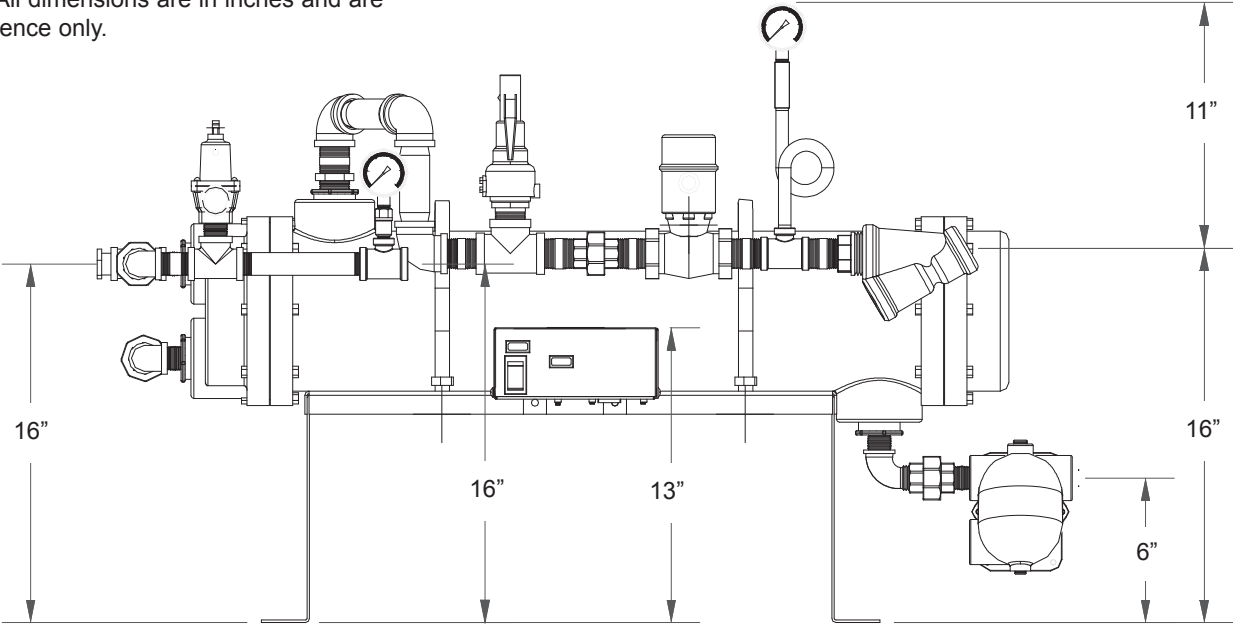

SECTION 1: SPECIFICATION INFORMATION

D226 STEAM BOOSTER PLUMBING LINE DRAWINGS

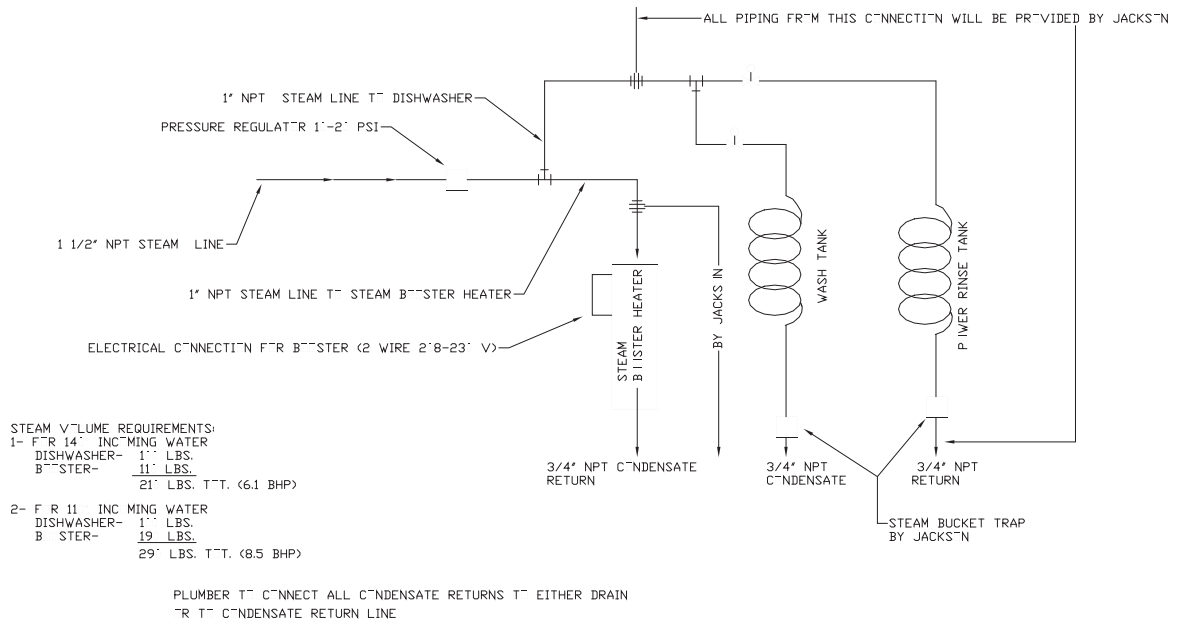

Steam Booster Piping - Double Tank Machine

SECTION 1: SPECIFICATION INFORMATION
TYPICAL ELECTRIC AND GAS BOOSTER DIMENSIONS

Electric Booster Dimensions (Typical)

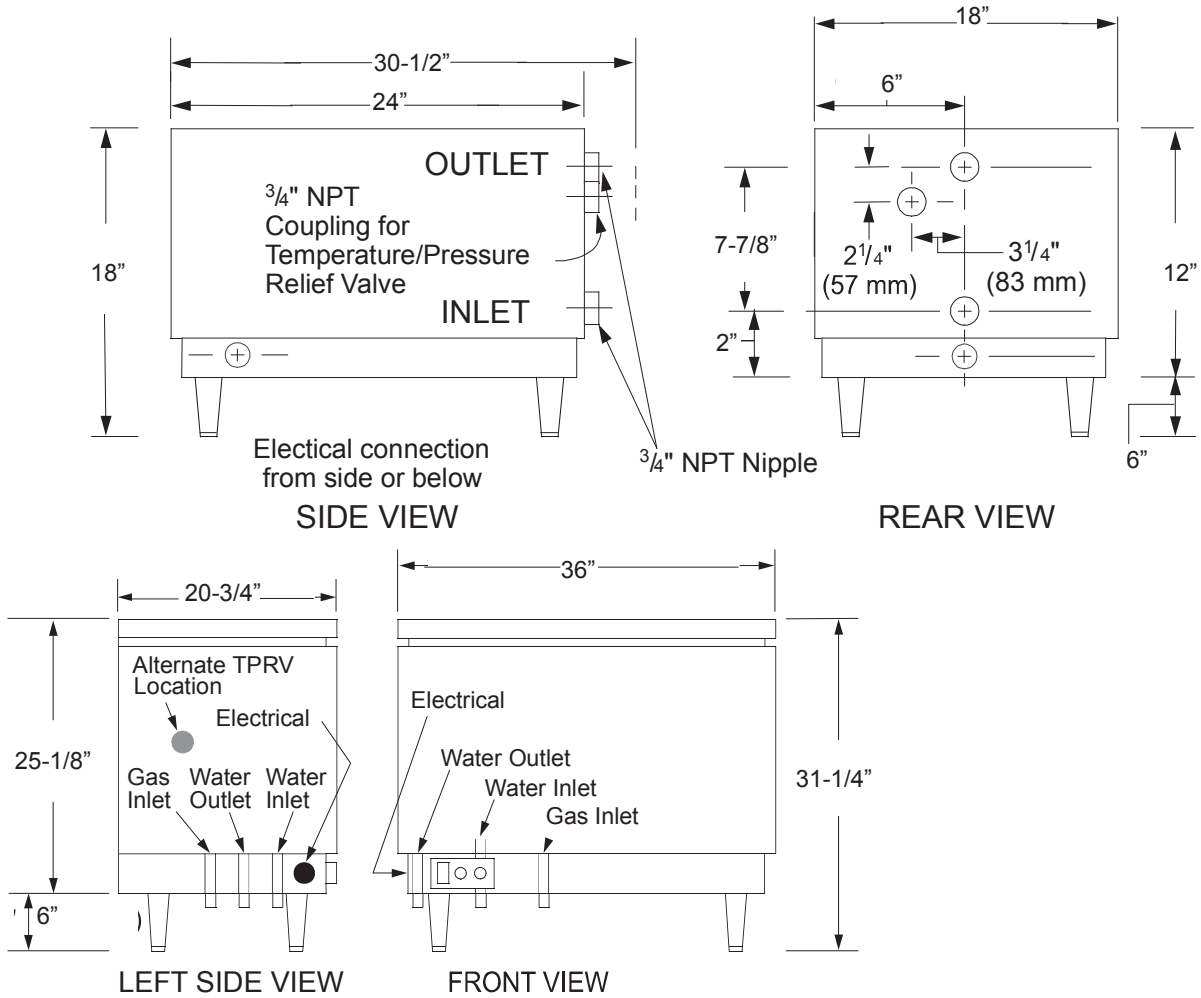

Gas Booster Dimensions (Typical)

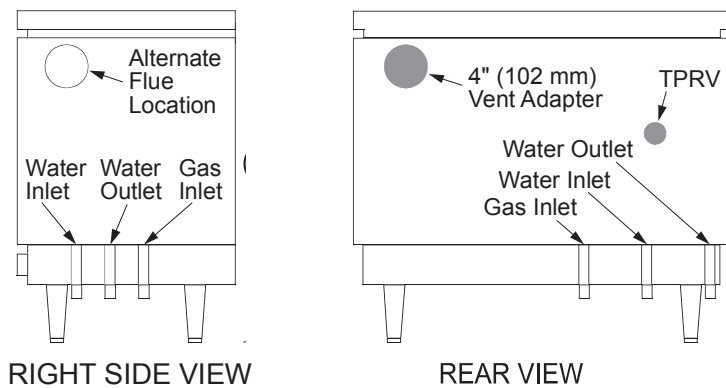

**SECTION 2:
INSTALLATION/OPERATION
INSTRUCTIONS**

SECTION 2: INSTALLATION/OPERATION INSTRUCTIONS

INSTALLATION INSTRUCTIONS



NOTE: THE INSTRUCTIONS PROVIDED HEREIN, UNLESS OTHERWISE SPECIFIED ARE FOR THE DISHMACHINES ONLY. THERE ARE SEPARATE DIRECTIONS FOR THE GAS BOOSTER.

VISUAL INSPECTION: Before installing the unit, check the container and machine for damage. A damaged container is an indicator that there may be some damage to the machine. If there is damage to both the container and machine, do not throw away the container. The dishmachine has been inspected and packed at the factory and is expected to arrive to you in new, undamaged condition. However, rough handling by carriers or others may result in damage to the unit while in transit. If such a situation occurs, do not return the unit to Jackson; instead, contact the carrier and ask them to send a representative to the site to inspect the damage to the unit and to complete an inspection report. You must contact the carrier within 48 hours of receiving the machine. Also, contact the dealer through which you purchased the unit.

UNPACKING THE DISHMACHINE: The machine should be unboxed and removed from shipping pallet prior to being installed. Open the front door and remove all of the packing materials. Once unpacked, ensure that there are no missing parts from the machine. This may not be obvious at first. If it is discovered that an item is missing, contact Jackson immediately.

LEVEL THE DISHMACHINE: The dishmachine is designed to operate while being level. This is important to prevent any damage to the machine during operation and to ensure the best results when washing ware. The unit comes with adjustable bullet feet, which can be turned using a pair of channel locks or by hand if the unit can be raised safely. Ensure that the unit is level from side to side and from front to back before making any connections. You will be able to adjust the overall height of the unit by turning the bullet feet from between 75-1/2" to 76-1/2".

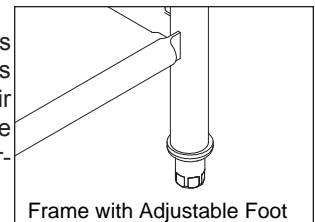

Frame with Adjustable Foot

PLUMBING THE DISHMACHINE: All plumbing connections must comply with all applicable local, state, and national plumbing codes. The plumber is responsible for ensuring that the incoming water line is thoroughly flushed prior to connecting it to any component of the dishmachine. It is necessary to remove all foreign debris from the water line that may potentially get trapped in the valves or cause an obstruction. Any valves that are fouled as a result of foreign matter left in the water line, and any expenses resulting from this fouling, are not the responsibility of the manufacturer.

Water hardness should be a maximum of 6 grains per gallon. Harder water should be treated prior to using the machine. Iron in the water supply can cause staining. A filter designed to remove iron from the supply water is highly recommended for supplies in excess of 0.1 ppm (parts per million).

CONNECTING THE DRAIN LINE: The drain for the models covered in this manual are gravity discharge drains. All piping from the machine to the drain must be a minimum 1 1/2" NPT and should not be reduced. There must also be an air gap between the machine drain line and the floor sink or drain. If a grease trap is required by code, it should have a flow capacity of 30 gallons per minute.

WATER SUPPLY CONNECTION: Ensure that you have read the section entitled "PLUMBING THE DISHMACHINE" above before proceeding. It is also recommended that a pressure regulator (not supplied) be installed in the incoming water line. The supply water temperature must meet the minimum requirements listed on the machine data plate. Install the water supply line (3/4" pipe size minimum) to the dishmachine line strainer. It is recommended that a water shut-off valve be installed in the water line between the main supply and the machine to allow access for service. The water supply line is to be capable of 25 PSI "flow" pressure at the recommended temperature indicated on the data plate.

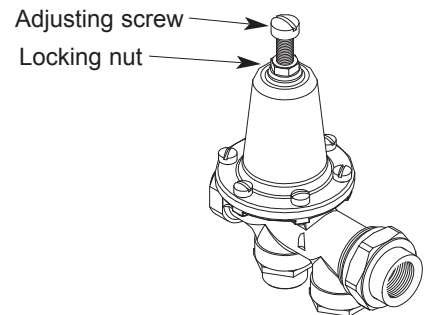

Incoming Plumbing Assembly

(Optional)

If the water level is too low or too high, check the incoming water pressure. It should be 20 ± 5 PSI. Too high of pressure results in too much water; too low of pressure results in too little water. To adjust the regulator, loosen the nut at the top, this will allow you to screw or unscrew the adjustment. With a screwdriver, turn the adjuster clockwise to increase pressure or counter clockwise to decrease it.

Do not confuse static pressure with flow pressure. Static pressure is the line pressure in a "no flow" condition (all valves and services are closed). Flow pressure is the pressure in the fill line when the fill valve is opened during the cycle.

It is also recommended that a shock absorber (not supplied) be installed in the incoming water line. This prevents line hammer (hydraulic shock), induced by the solenoid valve as it operates, from causing damage to the equipment.

SECTION 2: INSTALLATION/OPERATION INSTRUCTIONS

INSTALLATION INSTRUCTIONS (CONTINUED)

STEAM LINE CONNECTIONS: Some machines covered in this manual are designed to use low pressure steam as a source of heat for wash tank water. The machines come with lines by which outside source steam needs to be connected. Connect all incoming steam lines in accordance with the steam booster manufacturer's instructions. Ensure that all applicable codes and regulations are adhered to. See machine data plate for information concerning steam flow pressure.

GAS CONNECTIONS: Some machines covered in this manual are designed to use gas as an outside source of heat for wash tank water. The machines come with connections by which an outside source needs to be connected. Connect all incoming gas lines in accordance with the gas booster manufacturer's instructions. Ensure that all applicable codes and regulations are adhered to.

PLUMBING CHECK: Slowly turn on the water supply to the machine after the incoming fill line and the drain line have been installed. Check for any leaks and repair as required. All leaks must be repaired prior to placing the machine in operation.

ELECTRICAL POWER CONNECTION: Electrical and grounding connections must comply with the applicable portions of the National Electrical Code ANSI/NFPA 70 (latest edition) and/or other electrical codes.

Disconnect electrical power supply and place a tag at the disconnect switch to indicate that you are working on the circuit.

The dishmachine data plate is located on the right side and to the front of the machine. Refer to the data plate for machine operating requirements, machine voltage, total amperage load and serial number.

To install the incoming power lines, open the control box. Install conduit into the pre-punched holes in the back of the control box. Route power wires and connect to power block and grounding lug. Install the service wires (L1, L2, and L3 (3 phase only)) to the appropriate terminals as they are marked on the terminal block. Install the grounding wire into the lug provided. Tighten the connections. It is recommended that "DE-OX" or another similar anti-oxidation agent be used on all power connections.

VOLTAGE CHECK: Ensure that the power switch is in the OFF position and apply power to the dishmachine. Check the incoming power at the terminal block and ensure it corresponds to the voltage listed on the data plate. If not, contact a qualified service agency to examine the problem. Do not run the dishmachine if the voltage is too high or too low. Shut off the service breaker and mark it as being for the dishmachine. Advise all proper personnel of any problems and of the location of the service breaker. Replace the control box cover and tighten down the screws.

VENTILATION OF DISHMACHINE: The dishmachine should be located with provisions for venting into an adequate exhaust hood or ventilation system. This is essential to permit efficient removal of the condensation exhaust. Ensure that the exhaust system is acceptable in accordance with all applicable codes and standards.

NOTE: Any damage that is caused by steam or moisture due to improper ventilation is NOT covered under the warranty.

This units covered in this manual have the following exhaust requirements:

Load End:	200 CFM
Unload End:	400 CFM

The exhaust system must be sized to handle this volume for the dishmachine to operate as it was designed to.

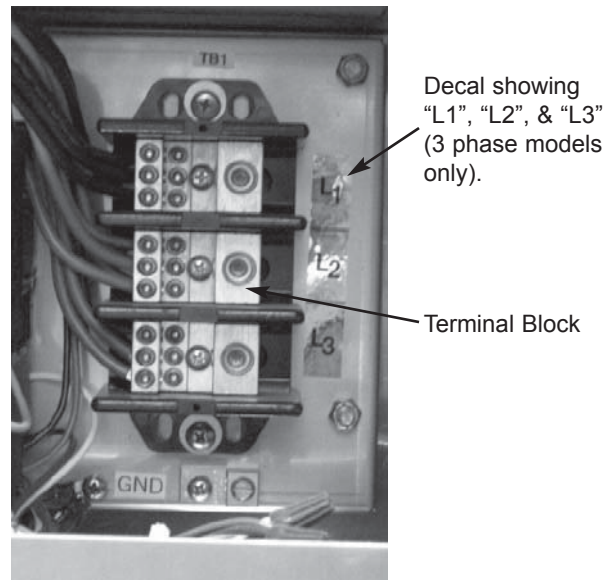

Incoming Power Connection

SECTION 2: INSTALLATION/OPERATION INSTRUCTIONS

INSTALLATION INSTRUCTIONS (CONTINUED)

ELECTRIC HEAT: The thermostats for the machines covered in this manual are factory set. They should not be adjusted except by an authorized service agent.

CHEMICAL FEEDER EQUIPMENT: Detergent may be introduced into the unit through the removal of the bulkhead plug in the rear of the tub and replacing it with the third party detergent injection fitting. Remove the bulkhead plug in the side of the tub to install the detergent concentration probe.

For more information concerning detergent concerns, please refer to the page entitled "Detergent Control".

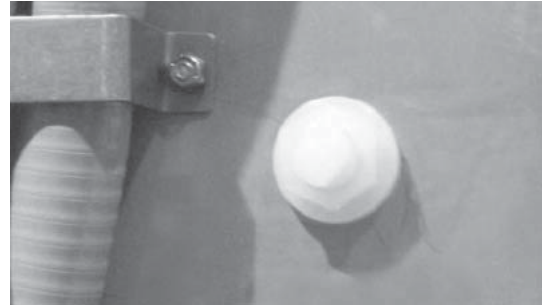

Detergent Connection Point
(Machine rear view)

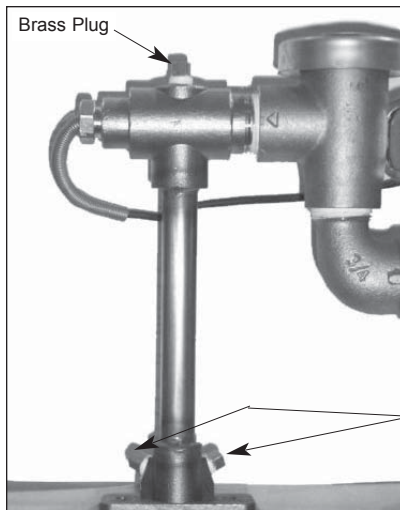

The 1/8" brass plugs on the incoming plumbing rinse injector may be removed to install rinse aid injection fittings.

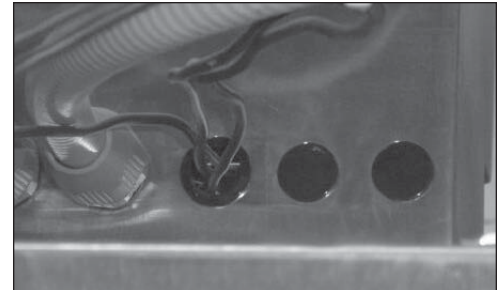

All wires for the chemical injectors should be routed through one of the extra openings in the back of the control box.

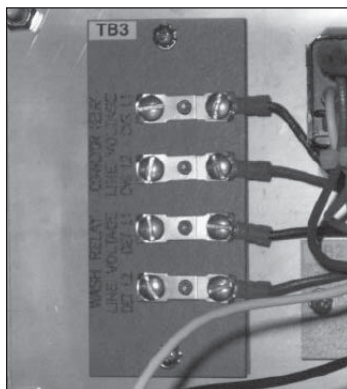

Connection Points

Terminals in the control box marked "CVS" provide a constant voltage signal whenever the drive motor is operating.

Terminals in the control box marked "DET" provide a voltage signal whenever the wash motor is operating.

SECTION 2: INSTALLATION/OPERATION INSTRUCTIONS

DELIMING OPERATIONS

DELIMING OPERATIONS: In order to maintain the dishmachine at its optimum performance level, it will be required to remove lime and corrosion deposits on a frequent basis. A deliming solution should be available from your detergent supplier. Read and follow all instructions on the label of the deliming solution.

To proceed with the delimiting operation, fill the dishmachine and add the correct amount of delimiting solution as recommended by the delimiting solution manufacturer. The water capacity of the various tanks of the dishmachine can be verified on the specification sheet(s) of this manual.

Perform the following operations to delime the dishmachine:

1. Turn the AUTOMATIC/DELIME switch on the back of the control box to the DELIME position.
2. Disconnect or turn off all chemical feeder pumps.
3. Close all doors (after adding the delimiting solution).
4. Run the machine for the recommended period of time.
5. Turn the unit off and open the doors.
6. Wait five minutes, then inspect the inside of the machine. If the machine is not delimed, run another time cycle as per the delimiting solution's instructions.
7. When clean, drain and re-fill the machine.
8. Run in MANUAL for 10 minutes to remove residual delimiting solution.
9. Drain and re-fill the machine.



Delime Switch

This equipment is not recommend for use with deionized water or other aggressive fluids. Use of deionized water or other aggressive fluids will result in corrosion and failure of materials and components. Use of deionized water or other aggressive fluids will void the manufacturer's warranty.

SECTION 2: INSTALLATION/OPERATION INSTRUCTIONS

CURTAIN INSTALLATION DIAGRAMS

Please refer to the chart for placement of the curtains.

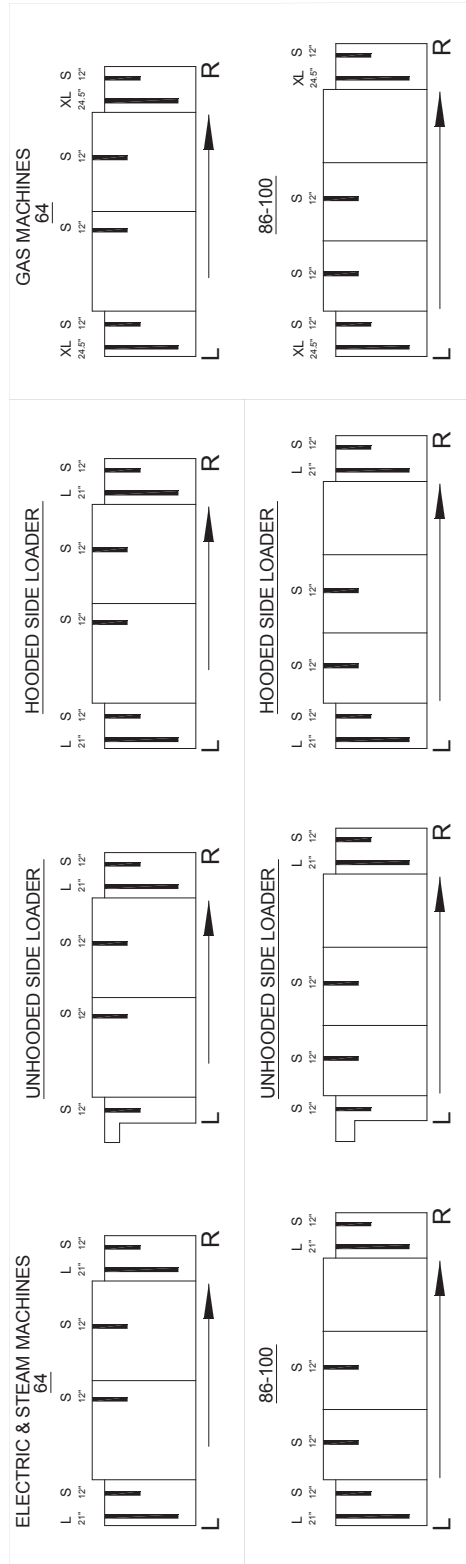

SECTION 2: INSTALLATION/OPERATION INSTRUCTIONS

SIDE LOADER INSTALLATION & OPERATION INSTRUCTIONS

This accessory assists in the delivery of a full dish rack from the break down (scrapping) table to the dishmachine. It will convert the direction of travel 90°. Since the Side Loader is shipped mounted on the conveyor dishwasher there is no additional installation required for this option. As it is operated mechanically by the dishwasher it does not require any plumbing or electrical connections.

This Side Loader does not require or add any additional electrical or mechanical devices to the unit which could create operational or maintenance problems. As designed the drive mechanism is powered by the conveyor drive motor on the dishmachine. An extension on the pawl bar provides the drive to push the racks into the unit.

PREPARATION: Before proceeding with the start-up of the unit, verify that the Side Loader pan strainer is installed.

WARE PREPARATION: Proper preparation of ware will help ensure good results and less re-washes. If not done properly, ware may not come out clean and the efficiency of the dishmachine will be reduced. It is important to remember that a dishmachine is not a garbage disposal and that simply throwing unscrapped dishes into the machine simply defeats the purpose altogether of washing the ware. Scraps should be removed from ware prior to being loaded into a rack. Pre-rinsing and pre-soaking are good ideas, especially for silverware and casserole dishes. Place cups and glasses upside down in racks so that they do not hold water during the cycle. The dishmachine is meant not only to clean, but to sanitize as well, to destroy all of the bacteria that could be harmful to human beings. In order to do this, ware must be properly prepared prior to being placed in the machine.

WASHING A RACK OF WARE: Once a rack is fully loaded it should be positioned against the front of the dish table. The rack should then be moved into the Side Loader until it activates the actuator switch. Once the machine is started, it should pull the rack through the machine and push it out the unload end. Once a rack has started through, you may put another rack in.

OPERATIONAL INSPECTION: Based upon usage, the pan strainer may become clogged with soil and debris as the workday progresses. Operators should regularly inspect the pan strainer to ensure it has not become clogged. If the strainer does become clogged, it will reduce the washing capability of the machine. Instruct operators to clean out the pan strainer at regular intervals or as required by work load.

SHUTDOWN AND CLEANING: At the end of the workday, remove the pan strainer and clean as required. Wipe out the inside of the Side Loader and then reinsert the strainer.

SECTION 2: INSTALLATION/OPERATION INSTRUCTIONS

D226 STEAM BOOSTER INSTALLATION & OPERATION INSTRUCTIONS

CONCEALED DAMAGE OR MISSING PARTS:



IMPORTANT: FOR YOUR PROTECTION, PLEASE READ AND OBSERVE THE FOLLOWING:

This steam booster has been thoroughly inspected and carefully packed before leaving our warehouse.

Concealed loss or damage means loss or damage which does not become apparent until the booster has been unpacked. The contents may be damaged in transit due to rough handling even though the carton may not show external damage.

If it is found that the shipment has concealed damage, PLEASE DO NOT RETURN IT TO JACKSON, but notify the carrier (within 48 hours) asking them to send their agent to fill out an inspection report. Save the cartons so he may inspect them and be sure to note in the report any black marks, creases, tears, crushed corners or any other marks indicating rough handling. Also, notify your JACKSON dealer immediately.

If it is discovered that there are missing parts, please notify your JACKSON dealer immediately.

EQUIPMENT MOUNTING:

Your booster should come pre-assembled and will require that it be permanently mounted in place. The platform has pre-punched holes to allow for mounting to the installation floor. **NOTE:** The D226 Booster must be properly mounted and level before being used. Once the platform is secure to the floor, attach the water and steam lines in accordance with local and national codes.

PLUMBING:

NOTE: ALL CONNECTIONS MUST COMPLY WITH ALL APPLICABLE LOCAL, STATE AND NATIONAL PLUMBING CODES.

The plumber is responsible for ensuring that the water line is **THOROUGHLY FLUSHED BEFORE** connecting it to any manual or solenoid valve. It is necessary to remove all foreign matter such as chips (resulting from cutting or threading pipes), pipe joint compound or, if soldered fittings are used, bits of solder or cuttings from the lines. This debris, if not removed, may lodge in the valves and render them inoperative.

The D226 Booster is designed to take incoming water from a minimum temperature of 110°F to approximately 180°F for use in the final rinse of your Jackson dishmachine. In order to do this, water is supplied to the booster and is heated by tubes carrying 15-25 PSIG flow steam. Heat is transferred from the steam into the water, raising the temperature.

Install condensate drains in accordance with applicable codes.

The D226 Booster is designed to operate at a water flow rate of 20 ± 5 PSI. The assembly comes with a water pressure regulator, which is preset at the factory. However, adjustment may be required so ensure that you verify the the flow pressure before beginning operations. See the instructions regarding adjustment and maintenance of the water pressure regulator for more information.



WARNING: The D226 Booster is designed to heat water to a minimum of 180°F and is extremely hot during operations. Advise personnel of the dangers associated with touching booster components as burns or severe injury can occur.



This equipment is not recommend for use with deionized water or other aggressive fluids. Use of deionized water or other aggressive fluids will result in corrosion and failure of materials and components. Use of deionized water or other aggressive fluids will void the manufacturer's warranty.

SECTION 2: INSTALLATION/OPERATION INSTRUCTIONS

D226 STEAM BOOSTER INSTALLATION & OPERATION INSTRUCTIONS (CONTINUED)

ELECTRICAL:

! WARNING: Electrical and grounding connections must comply with applicable portions of the National Electrical Code ANSI / NFPA 70 (latest edition) and/or other electrical codes. Disconnect electrical power supply and place a tag or lock at the disconnect switch to indicate that you are working on the circuit.

To connect the incoming power, run the conduit for power wires through the open hole in the back of the control box. Connect the power wires to the terminal block as it is labeled (L1 and L2). Run the ground wire to the grounding lug marked "GND". Tight connections and conduit nuts and close the control box by putting the cover on and securing with the 10-32 screws.

OPERATION:

! WARNING: The heat exchanger used in the D226 Booster system is a pressure vessel with very precise operating parameters. Safety equipment such as relief valves should never be tampered with or disabled. These devices are meant to protect the equipment and the operator from harm, damage and death.

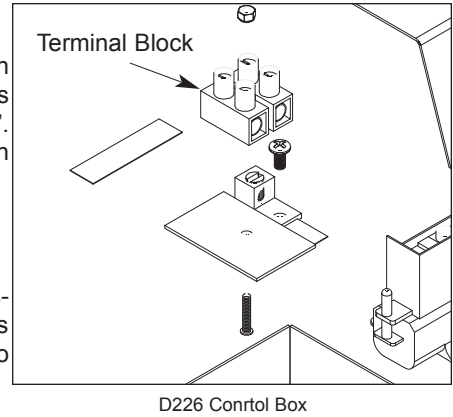

1. Ensure that water, steam and any condensate drains are connected to the booster.
2. Start the water flow first, open the condensate drains and then begin steam flow.
3. On the control box, press the power switch and put it in the ON position. The power light should illuminate.

The unit should run normally now.

! WARNING: Do not shock the system by applying the steam before the water. This can cause damage to the booster.

The following explanation describes the operation of the D226 Booster.

NOTE: This explanation assumes that water and steam have been connected to the machine.

1. When the power switch (S1) is placed in the ON position, power is provided to both the power light (E1) and the thermostat (TS1).
2. The thermostat (TS1) will close when the water falls below the minimum setpoint, energizing the steam solenoid light (E2) and the steam solenoid (FS1).
3. The steam solenoid (FS1) will remain open, allowing steam into the booster, until the water temperature reaches the desired temperature. At that point, the thermostat (TS1) will open, de-energizing the steam solenoid (FS1) and the steam solenoid light (E2).

! IMPORTANT: Please remember that all of the components in the control box are under line voltage (208-240 volts). Under no circumstance is the control box cover to be removed or opened during normal operations!

SHUTDOWN (FOR SERVICE ONLY):

! WARNING: The D226 Booster is designed to heat water to a minimum of 180°F and is extremely hot during operations. Advise personnel of the dangers associated with touching booster components as burns or severe injury can occur.

1. Turn the power switch to the OFF position. The power light should extinguish.
2. Secure steam flow to the unit.
3. Secure water flow.
4. Close the condensate drains as required by procedure and/or code.
5. Do not attempt to clean, wipe down or perform any maintenance on the booster until it has been given a generous amount of time to cool down.

SECTION 2: INSTALLATION/OPERATION INSTRUCTIONS

GAS CONVEYOR HOSE INSTALLATION

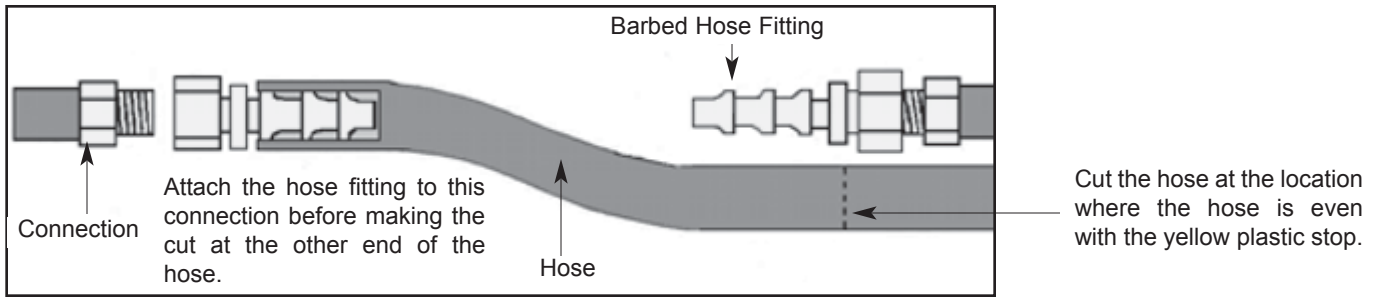

Due to the fact that each customer may have different requirements for the orientation of the gas booster heater relative to the main dishmachine, the hose lengths that connect the two units must be customized during each installation. The appropriate 3/4" hosing, fittings and gaskets have been provided.

To prevent incorrect measurements of the hose, it is recommended to place one barbed hose fitting into the end of the uncut length of hose coil and attach that fitting to an appropriate connection. Run the hose to the corresponding connection on the other unit before cutting the hose. Use a barbed hose fitting that is screwed into the second connection on the other unit before cutting the hose. Use a barbed hose fitting that is screwed onto the second connection to gauge the correct distance. Ensure a smooth "flow" of hose without any sharp turns or kinks.

To aid in pushing the barbed hose fitting into the hose, place the fitting on a hard surface (i.e. the floor) with the barbed end of the fitting pointing upward and push the hose down onto the fitting. A small amount of lubricant (i.e. petroleum jelly) may aid in this process.

SECTION 2: INSTALLATION/OPERATION INSTRUCTIONS

GAS CONVEYOR HOSE INSTALLATION (CONTINUED)

TYPICAL RECIRCULATING WATER HOOK-UP FOR ALL GAS HEATED CONVEYORS

HOOKUP WHEN GAS BOOSTER HEATER IS LOCATED TO THE **LEFT** OF THE DISHMACHINE

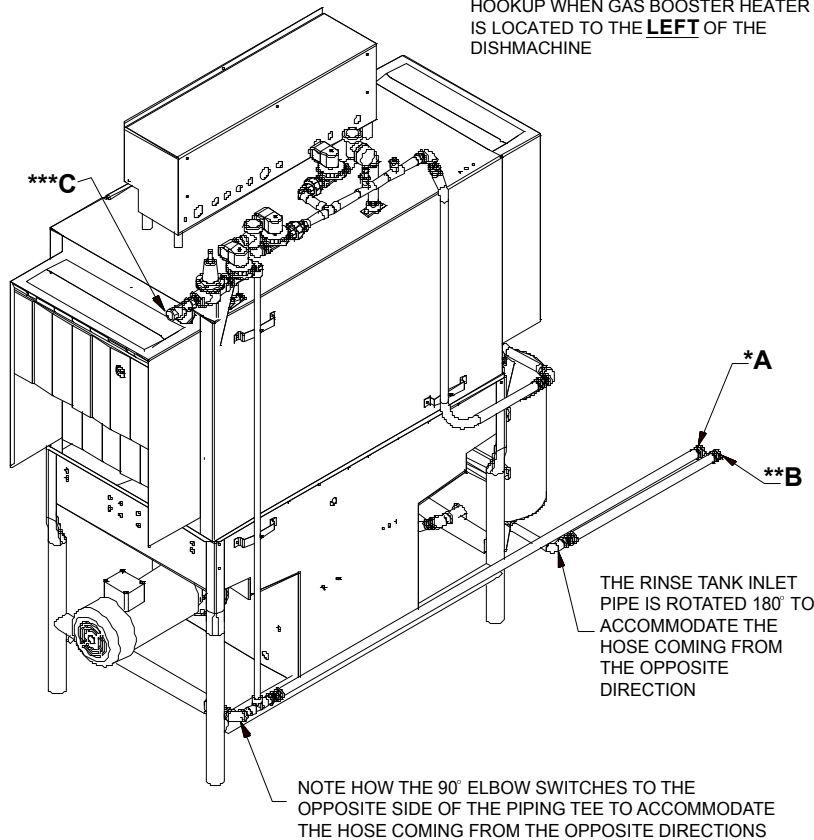

HOOKUP WHEN GAS BOOSTER HEATER IS LOCATED TO THE **RIGHT** OF THE DISHMACHINE

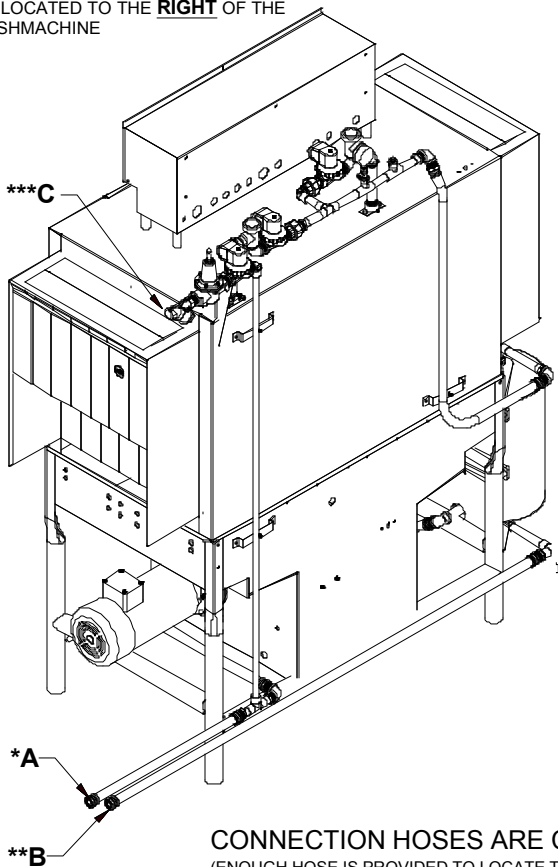

CONNECTION HOSES ARE CUT TO LENGTH DURING INSTALLATION.

(ENOUGH HOSE IS PROVIDED TO LOCATE THE GAS BOOSTER HEATER APPROXIMATELY 9 FEET AWAY FROM THE DISHMACHINE. ADDITIONAL HOSE MUST BE ORDERED IF A GREATER DISTANCE IS REQUIRED. DISTANCES GREATER THAN 20 FEET AWAY CAN AFFECT THE HEATING PERFORMANCE OF THE UNIT)

* HOSES MARKED **A** IN THE ABOVE ILLUSTRATIONS CONNECT TO THE **INLET** WATER CONNECTION OF THE GAS BOOSTER HEATER

** HOSES MARKED **B** IN THE ABOVE ILLUSTRATIONS CONNECT TO THE **OUTLET** WATER CONNECTION OF THE GAS BOOSTER HEATER

*** ITEMS MARKED **C** ARE THE INCOMING PLUMBING CONNECTIONS TO MACHINE THAT SHOULD BE 110 - 140 DEGREES

SECTION 2: INSTALLATION/OPERATION INSTRUCTIONS

DISHMACHINE OPERATING INSTRUCTIONS

PREPARATION: Before proceeding with the start-up of the unit, verify the following:

1. Close door(s) on dishmachine.
2. Close the drain valve(s).

POWER UP (ELECTRICALLY-HEATED MODELS): To energize the unit, turn on the power at the service breaker. The voltage should have been previously verified as being correct. If not, the voltage will have to be verified.

POWER UP (STEAM-HEATED MODELS): To energize the unit, turn on the power at the service breaker. The voltage should have been previously verified as being correct. If not, the voltage will have to be verified. Ensure that the steam service is connected and that steam is flowing to the machine. Without steam, the water will not reach the required minimum temperatures that the machine is designed to operate at.

POWER UP (GAS-HEATED MODELS): To energize the unit, turn on the power at the service breaker. The voltage should have been previously verified as being correct. If not, the voltage will have to be verified. Ensure that the gas service is connected and that gas is flowing to the machine. Without gas, the water will not reach the required minimum temperatures that the machine is designed to operate at.

FILLING THE WASH TUB: Ensure that the delime switch is in the NORMAL position, and place the power switch into the ON position. The machine should fill automatically and shut off when the appropriate level is reached (just below the pan strainer). The wash tub must be completely filled before operating the wash pump to prevent damage to the component. Once the wash tub is filled, the unit is ready for operation.



Machines equipped with prewash sections should not be run without water in those sections. This can cause damage to components.

WARE PREPARATION: Proper preparation of ware will help ensure good results and less re-washes. If not done properly, ware may not come out clean and the efficiency of the dishmachine will be reduced. It is important to remember that a dishmachine is not a garbage disposal and that simply throwing unscrapped dishes into the machine simply defeats the purpose altogether of washing the ware. Scraps should be removed from ware prior to being loaded into a rack. Pre-rinsing and pre-soaking are good ideas, especially for silverware and casserole dishes. Place cups and glasses upside down in racks so that they do not hold water during the cycle. The dishmachine is meant not only to clean, but to sanitize as well, to destroy all of the bacteria that could be harmful to human beings. In order to do this, ware must be properly prepared prior to being placed in the machine.

DAILY MACHINE PREPARATION: Refer to the section entitled "PREPARATION" at the top of this page and follow the instructions there. Afterwards, check that all of the chemical levels are correct and/or that there is plenty of detergent available for the expected workload.

WASHING A RACK OF WARE: To wash a rack, simply slide a rack of soiled ware into the load end of the machine. Once the machine is started, it should pull the rack through the machine and push it out the unload end. Once a rack has started through, you may put another rack in.

OPERATIONAL INSPECTION: Based upon usage, the pan strainers may become clogged with soil and debris as the workday progresses. Operators should regularly inspect the pan strainers to ensure they have not become clogged. If the strainers do, they will reduce the washing capability of the machine. Instruct operators to clean out the pan strainers at regular intervals or as required by work load.

NOTE: On units equipped with prewash sections (AJ-86 and AJ-100), operators should also take the time to inspect the prewash section strainers and clean them as required by workload.

SHUTDOWN AND CLEANING (ELECTRICALLY-HEATED MODELS): At the end of the workday, place the power switch in the OFF position and open the door(s). Open the drain valves and allow the machine to drain completely. Remove the pawl bar assembly (clean as required). Remove the pan strainers and, if equipped, the prewash strainers, run off sheets and scrap basket strainer. Remove the wash and, if equipped, the prewash arms and verify that the nozzles and arms are free from obstructions. Flush the arms with fresh water. Remove the pump suction strainers and clean out as required. Remove the rinse tray assembly and clean. Remove the curtains and scrub with a mild detergent and warm water. Wipe out the inside of the unit and then reassemble with the components previously removed.

SECTION 2: INSTALLATION/OPERATION INSTRUCTIONS

DISHMACHINE OPERATION INSTRUCTIONS (CONTINUED)

SHUTDOWN AND CLEANING (STEAM-HEATED MODELS): At the end of the workday, place the power switch in the OFF position, secure the flow of steam to the machine and open the door(s). Open the drain valves and allow the machine to drain completely. Remove the pawl bar assembly (clean as required). Remove the pan strainers and, if equipped, the prewash strainers, run off sheets and scrap basket strainer. Remove the wash and, if equipped, the prewash arms and verify that the nozzles and arms are free from obstructions. Flush the arms with fresh water. Remove the pump suction strainers and clean out as required. Remove the rinse tray assembly and clean. Remove the curtains and scrub with a mild detergent and warm water. Wipe out the inside of the unit and then reassemble with the components previously removed.

SHUTDOWN AND CLEANING (GAS-HEATED MODELS): At the end of the work day, shut down the gas booster in accordance with manufacturer's instructions. Place the power switch in the OFF position, secure the flow to the machine and open the door(s). Open the drain valves and allow the machine to drain completely. Remove the pawl bar assembly (clean as required). Remove the pan strainers and, if equipped, the prewash strainers, run off sheets and scrap basket strainer. Remove the wash and, if equipped, the prewash arms and verify that the nozzles and arms are free from obstructions. Flush the arms with fresh water. Remove the pump suction strainers and clean out as required. Remove the rinse tray assembly and clean. Remove the curtains and scrub with a mild detergent and warm water. Wipe out the inside of the unit and then reassemble with the components previously removed.

SECTION 2: INSTALLATION/OPERATION INSTRUCTIONS

DETERGENT CONTROL

Detergent usage and water hardness are two factors that contribute greatly to how efficiently your dishmachine will operate. Using detergent in the proper amount can become, in time, a source of substantial savings. A qualified water treatment specialist can tell you what is needed for maximum efficiency from your detergent, but you should still know some basics so you'll understand what they are talking about.

First, you must understand that hard water greatly effects the performance of the dishmachine. Water hardness is the amount of dissolved calcium and magnesium in the water supply. The more dissolved solids in the water, the greater the water hardness. Hard water works against detergent, thereby causing the amount of detergent required for washing to increase. As you use more detergent, your costs for operating the dishmachine will increase and the results will decrease. The solids in hard water also may build-up as a scale on wash and rinse heaters, decreasing their ability to heat water. Water temperature is important in removing soil and sanitizing dishes. If the water cannot get hot enough, your results may not be satisfactory. This is why Jackson recommends that if you have installed the machine in an area with hard water, that you also install some type of water treatment equipment to help remove the dissolved solids from the water before it gets to the dishmachine.

Second, hard water may have you adding drying agents to your operating cycle to prevent spotting, when the real problem is deposited solids on your ware. As the water evaporates off of the ware, the solids will be left behind to form the spotting and no amount of drying agent will prevent this. Again, using treated water will undoubtedly reduce the occurrences of this problem.

Third, treated water may not be suitable for use in other areas of your operation. For instance, coffee made with soft water may have an acid or bitter flavor. It may only be feasible to install a small treatment unit for the water going into the dishmachine itself. Discuss this option with your qualified water treatment specialist.

Even after the water hardness problems have been solved, there still must be proper training of dishmachine operators in how much detergent is to be used per cycle. Talk with your water treatment specialist and detergent vendor and come up with a complete training program for operators. Using too much detergent has as detrimental effects as using too little. The proper amount of detergent must be used for job. It is important to remember that certain menu items may require extra detergent by their nature and personnel need to be made aware of this. Experience in using the dishmachine under a variety of conditions, along with good training in the operation of the machine, can go a long way in ensuring your dishmachine operates as efficiently as possible.

Certain dishmachine models require that chemicals be provided for proper operation and sanitization. Some models even require the installation of third-party chemical feeders to introduce those chemicals to the machine. Jackson does not recommend or endorse any brand name of chemicals or chemical dispensing equipment. Contact your local chemical distributor for questions concerning these subjects.

Some dishmachines come equipped with integral solid detergent dispensers. These dispensers are designed to accommodate detergents in a certain sized container. If you have such a unit, remember to explain this to your chemical distributor upon first contacting them.

As explained before, water temperature is an important factor in ensuring that your dishmachine functions properly. The data plate located on each unit details what the minimum temperatures must be for either the incoming water supply, the wash tank and the rinse tank, depending on what model of dishmachine you have installed. These temperatures may also be followed by temperatures that Jackson recommends to ensure the highest performance from you dishmachine. However, if the minimum requirements are not met, the chances are your dishes will not be clean or sanitized. Remember, a dish can look clean, but it may not be sanitized. Instruct your dishmachine operators to observe the required temperatures and to report when they fall below the minimum allowed. A loss of temperature can indicate a much larger problem such as a failed heater or it could also indicate that the hot water heater for your operation is not up to capacity and a larger one may need to be installed.

There are several factors to consider when installing your dishmachine to ensure that you get the best possible results from it and that it operates at peak efficiency for many years. Discuss your concerns with your local chemical distributor and water treatment specialist before there is a problem.

SECTION 2: INSTALLATION/OPERATION INSTRUCTIONS

STRIKER PLATE LIMIT SWITCH INSTALLATION INSTRUCTIONS

Installation Instructions:

1. Wiring: The switch is wired common and normally open because of the hinge design. By interrupting the line in series with the door switches, the dishmachine ceases to operate. Refer to the machine schematic for details on how to wire the switch.

2. Parts of the table switch are mounted in the dishtable, at the end of the table and under the table. See the drawing(s) for the relationship of the switch to the table.

3. Move the limit switch as far down on the two slots as possible and see that the limit switch is straight on the base plate. This might require adjustment of the nut on the connector for the limit switch.

4. Then adjust the inside and the outside connector nuts for the connector box so that it lines up even with the limit switch and the base plate.

5. Tighten down the nuts for the seal so that they are tight.

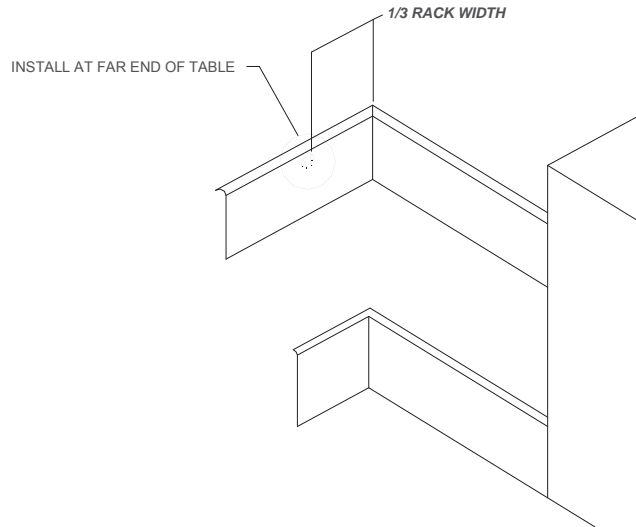

6. If you have any difficulty you might have to adjust the connectors to the seal, screwing in or screwing out until the installation is straight on the table and the limit switch is actuated correctly by the rack.

TABLE LIMIT SWITCH THROUGH ROD HOLES

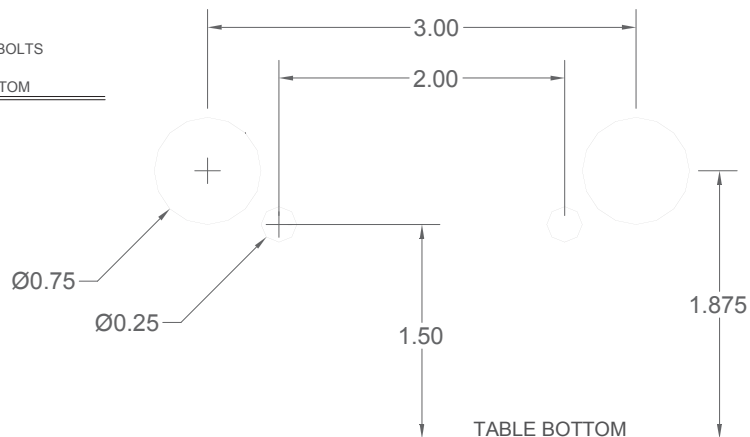
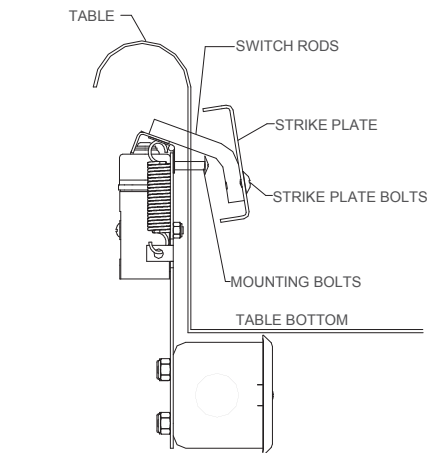

Unless noted, all dimensions are in inches.

SECTION 3: PREVENTATIVE MAINTENANCE

SECTION 3: PREVENTATIVE MAINTENANCE

PREVENTATIVE MAINTENANCE

The dishmachines covered in this manual are designed to operate with a minimum of interaction with the operator. However, this does not mean that some items will not wear out in time. Jackson highly recommends that any maintenance and repairs not specifically discussed in this manual should be performed by **QUALIFIED SERVICE PERSONNEL ONLY**. Performing maintenance on your dishmachine may void your warranty if it is still in effect, so if you have a question or concern, do not hesitate to contact Jackson.

There are many things that operators can do to prevent catastrophic damage to the dishmachine. One of the major causes of component failure has to do with prescraping procedures. A dishmachine is not a garbage disposal; any large pieces of material that are put into the machine shall remain in the machine until they are either broken up (after spreading out on your ware!) or physically removed. Strainers are installed to help catch debris, but they do no good if they are clogged. Have operators regularly inspect the pan strainers to ensure (1) that they are free of soil and debris and (2) they are laying flat in the tub.

When cleaning out strainers, do NOT beat them on waste cans. The strainers are made of metal and can be forgiving; but once severe damage is done, it is next to impossible for the strainer to work in the way it was designed to. Wipe out strainers with a rag and rinse under a faucet if necessary. For stubborn debris, a toothpick should be able to dislodge any obstructions from the perforations. Always ensure that strainers are placed back in the machine before operation and that they lay flat in the tub.

You may wish to also refer to the page entitled "Detergent Control" in order to learn more about how your water hardness will effect the performance of your machine. Hard water makes dishmachines work harder and decreases efficiency.

Again, it is important to remind operators that trying to perform corrective maintenance on the dishmachine could lead to larger problems or even cause harm to the operator. If a problem is discovered; secure the dishmachine using proper shut down procedures as listed in this manual and contact Jackson.

Some problems, however, may have nothing to do with the machine itself and no amount of preventative maintenance is going to help. A common problem has to do with temperatures being too low. Verify that the water temperatures coming to your dishmachine match the requirements listed on the machine data plate. There can be a variety of reasons why your water temperature could be too low and you should discuss it with Jackson to determine what can be done.

By following the operating and cleaning instructions in this manual, you should get the most efficient results from your machine. As a reminder, here are some steps to take to ensure that you are using the dishmachine the way it was designed to work:

1. Ensure that the water temperatures match those listed on the machine data plate.
2. Ensure that all strainers are in place before operating the machine.
3. Ensure that all wash and/or rinse arms are secure in the machine before operating.
4. Ensure that drains are closed/sealed before operating.
5. Remove as much soil from dishes by hand as possible before loading into racks.
6. Do not overfill racks.
7. Ensure that glasses are placed upside down in the rack.
8. Ensure that all chemicals being injected to machine have been verified as being at the correct concentrations.
9. Clean out the machine at the end of every workday as per the instructions in the manual.
10. Always contact Jackson whenever a serious problem arises.
11. Follow all safety procedures, whether listed in this manual or put forth by local, state or national codes/regulations.

SECTION 3: PREVENTATIVE MAINTENANCE

D226 MAINTENANCE

 **WARNING:** Maintenance should only be performed by authorized service personnel in order to ensure safe and effective workmanship, while minimizing danger to operating personnel. The D226 Steam Booster is designed to operate at temperatures capable of causing burns to personnel. Always allow the unit to cool down to an acceptable temperature prior to performing any maintenance.

Very little maintenance is required to be performed on the D226 Booster. So long as the steam and water used with the unit have the proper filtration and are operated at the correct temperature and pressures, then you should expect many years of reliable service out of your system.

MAINTENANCE OF THE WATER PRESSURE REGULATOR:

Incoming water pressure can be regulated by adjusting the water pressure regulator on the system. In order to adjust pressure, loosen the top nut on the regulator. This will allow you to turn the adjusting screw. Turn the adjusting screw clockwise to increase pressure and counter-clockwise to decrease. Pressure can be read on the pressure gauge located on the water outlet side of the heat exchanger. Once the desired pressure is achieved, tighten the top nut to ensure that the adjustment cannot be accidentally changed.

The water pressure regulator has an internal strainer that can be removed through the bottom hexagonal plug. This may need to be periodically checked depending on the water quality. It is important that the water supply to the water pressure regulator be secured prior to trying to clean the strainer.

MAINTENANCE OF THE RELIEF VALVES, SAFETY VALVES AND THERMOSTAT:

These components are shipped from the factory preset and should not be tampered with. None of these components are considered adjustable and no attempt should be made to do so. If a component does not appear to be working properly, then it should be replaced immediately by an authorized service representative.

SECTION 3: PREVENTATIVE MAINTENANCE

LUBRICATION CHART FOR DRIVE GEAR

Note: The maintenance procedures detailed here are manufacturer's instructions for the WINSMITH brand of gear reducer that is installed on the rack conveyors covered in this manual.

Ambient Temperature	-30 - 15°F	16 - 50°F	51 - 95°F	51 - 95°F	96 - 131°F	96 - 131°F
Final Stage Worm Speed ¹	up to 2000 FPM	up to 2000 FPM	up to 450 FPM	above 450 FPM	up to 450 FPM	above 450 FPM
ISO Viscosity Grade	220	460	680	460	680	460 ¹
AGMA Lubricant No.	5S	#7 Compounded	#8 Compounded	#7 Compounded	8S	7S
Mobil	SHC 630	600W Super Cylinder	Extra Hecla Super	600W Super Cylinder	SHC 636	SHC 634
American Lubricants	SHC-90W	AGMA #7 Gear Oil	AGMA #8 Gear Oil	AGMA #7 Gear Oil	N/A	N/A
Castrol	Tribol 800/220	Tribol 1105-7C	Tribol 1105-8C	Tribol 1105-7C	Tribol 800/680	Tribol 800/460
Chevron	Tegra 220	Cylinder Oil W460	Cylinder Oil W680	Cylinder Oil W460	Tegra 680	Tegra 460
Conoco	Syncon R & O 220	Inca Oil 460	Inca Oil 680	Inca Oil 460	N/A	Syncon R & O 460
Exxon (Esso)	Teresstic SHP220	Spartan EP 460	Spartan EP 680	Spartan EP 460	Teresstic SHP 680	Teresstic SHP 460
Fiske Brothers	SPO-MG	SPO-277	SPO-288	SPO-277	N/A	N/A
Shell	Omala RL 220	Valvata J 460	Valvata J 680	Valvata J 460	Omala RL 680	Omala RL 460
Texaco	Pinnacle 220	Vanguard 460	Vanguard 680	Vanguard 460	Pinnacle 680	Pinnacle 460

(1) The sliding velocity in feet per minute (FPM) for standard ratios is determined by multiplying the speed of the worm in RPM by the factor from the table below. For selecting proper lubricant, use the speed of the worm in the final stage (input RPM divided by the first stage ratio).

SECTION 3: PREVENTATIVE MAINTENANCE

DRIVE MOTOR GEAR REDUCER PREVENTATIVE MAINTENANCE

Note: The maintenance procedures detailed here are manufacturer’s instructions for the WINSMITH brand of gear reducer that is installed on the rack conveyors covered in this manual.

Lubrication & Maintenance:

Factory filling - WINSMITH speed reducers are oil filled at the factory to the proper level for the standard mounting position that you will find it in on the unit. The oil level should be checked and adjusted (if necessary) prior to operation, using the oil level plug provided and while the unit is oriented in its operating position.

Ambient temperature - If the operating ambient temperature is other than 51 - 95°F, then refer to the lubrication chart and refill the unit with the correct grade based on actual ambient temperature and operating speed. See “Oil changing” below for additional information.

Oil changing - When changing the oil for any reason, it should be remembered that oils of various types may not be compatible. Therefore, when changing to a different oil, it is recommended that the housing be completely drained and thoroughly flushed with a light flushing oil prior to refilling with the appropriate lubricant. The oil level should be rechecked after a short period of operation and adjusted, if necessary. When changing double reduction models, each housing should be drained and filled independently, even though there may be a common level.

Initial oil change: The new oil in a speed reducer should be changed at the end of 250 hours of operation. This is equivalent to 30 days of operation for 8 hours per day; 15 days of operation for 16 hours per day, or 10 days of operation for 24 hours per day.

Subsequent oil changes: Under normal conditions, after the initial oil change, the oil should be changed after every 2500 hours of operation, or every 6 months, whichever occurs first. Under severe conditions (rapid temperature changes, moist, dirty or corrosive environment) it may be necessary to change oil at intervals of one to three months. Periodic examination of oil samples taken from the unit will help establish the appropriate interval.

Synthetic oils: Synthetic lubricants can be advantageous over mineral oils in that they generally are more stable, have a much longer life, and operate over a wider temperature range. These oils are appropriate for any application but are especially useful when units are subjected to low start-up temperatures or high operating temperatures. However, continuous operation above 225°F may cause damage to seals or other components. It is recommended that the initial oil be changed or filtered after the first 1500 hours of operation to remove metal particles that accumulate during break-in. Subsequent oil changes should be made after 5000 hours operation if units are operating in a clean environment. This can be extended to 10,000 hours if using new reformulated Mobil SHC lubricants (orange in color) and the lubricant remains free of contamination over this period. See comments under “Subsequent oil changes” for discussion of severe ambient conditions.

Long term storage or infrequent operation: If a speed reducer is to stand idle for an extended period of time, either prior to installation or during use, it is recommended that the unit be filled completely with oil to protect interior parts from rust and corrosion due to internal condensation. Be sure to drain the oil to the proper level before placing the speed reducer in service.

Grease fittings: Some units are equipped with grease fittings to lubricate bearings not adequately lubricated by the oil splash. These fittings must be lubricated every 3 - 6 months depending on operating conditions. bearing greases must be compatible with the type of gear lubricant being used (i.e. mineral, synthetic, food grade, etc.). For mineral oils, use a high quality lithium base NLGOI #2 bearing grease. For synthetic oils, use a synthetic bearing grease such as Mobil Synthetic Universal gease, Mobilith SHC 100 or a suitable equivalent. For food grade lubricants, use Chevron FM grease, NGLI 2, or equivalent.

Low input speeds (under 1600 RPM): When input speeds are less than 1600 RPM, grease fittings will be required to lubricate any bearings not partially covered by the normal oil level.

Oil temperature: Speed reducers in normal operation can generate temperatures up to 200°F depending on the type of reducer and the severity of the application (loading, duration of service, ambient temperatures). Excessive oil temperatures may be the result of several factors including overloading, overfilling, underfilling or inadequate cooling.

Size	Nominal Ratio											
	5	7.5	10	15	20	25	30	40	50	60	80	100
920	0.347	0.263	0.225	0.216	0.202	0.191	0.215	0.200	0.188	0.182	0.164	0.161

Lubricant selections are provided by the lubricant manufacturer based on AGMA recommended viscosity grades. Viscosity grades are based on Lubrication Standard ANSI/AGMA 9005-D94.

SECTION 4: TROUBLESHOOTING SECTION

SECTION 4: TROUBLESHOOTING

COMMON PROBLEMS



WARNING: Inspection, testing and repair of electrical equipment should be performed only by qualified service personnel. Certain procedures in this section require electrical tests or measurements while power is applied to the machine. **Exercise extreme caution at all times.** If test points are not easily accessible, disconnect power, attach test equipment and reapply power to test. When replacing electrical parts, disconnect power at source circuit breaker.

Problem: Nothing on dishmachine operates. The power switch is ON and the power indicator light is OFF.

1. Machine is not wired correctly to incoming power source. Have an electrician verify wiring.
2. Machine circuit breaker is tripped. Reset the circuit breaker. If it trips again, contact an electrician to verify the machine amp draw.
3. Service breaker is tripped. Reset the service breaker. If it trips again, contact an electrician to verify the machine amp draw.

Problem: Machine will not fill. The power switch is ON and the power indicator light is ON.

1. No water supply to machine. Verify that water lines have been connected to the machine.
2. Dishmachine doors are not closed. Close doors completely.
3. Incoming water solenoid valve damaged/faulty. Verify that the valve is operating. If not, replace.
4. Tank floats faulty. Verify the wiring of the floats. Verify that no debris is jamming the floats. Replace if necessary.

Problem: Machine fills, but fill is weak.

1. Low incoming water pressure. Verify that incoming water pressure during fill is 20 ± 5 PSI.
2. Incoming water solenoid is clogged. Verify that debris is not entrapped in valve. If so, remove debris.

Problem: Low wash tank temperature.

1. Low incoming water temperature. Verify that the incoming water temperature matches what is indicated on the machine data plate.
2. Heater not energizing. Verify that the wash tank heater is operating. If not, replace.
3. Low incoming voltage. Have an electrician verify that the power coming to the machine is the same as indicated on the data plate.

Problem: Low wash arm pressure, poor spray pattern.

1. Clogged wash arm nozzles. Verify that nozzles are not clogged with debris. If so, remove debris.
2. Clogged wash tank or wash pump strainers. Clean out strainers if necessary.
3. Worn wash pump impeller. Verify status of impeller, replace if necessary.

Problem: Low prewash arm pressure, poor spray pattern.

1. Clogged prewash arm nozzles. Verify that nozzles are not clogged with debris. If so, remove debris.
2. Clogged prewash tank or prewash pump strainers. Clean out strainers if necessary.
3. Worn prewash pump impeller. Verify status of impeller, replace if necessary.

Problem: Inadequate rinse.

1. Low incoming water pressure. Verify that incoming water pressure during fill is 20 ± 5 PSI.
2. Incoming water solenoid is clogged. Verify that debris is not entrapped in valve. If so, remove debris.

Problem: Pawl bar moves with no load, but does not move when loaded.

1. Clutch on drive assembly is out of adjustment. Adjust as required.

SECTION 4: TROUBLESHOOTING

COMMON PROBLEMS

Problem: Pawl bar does not move.

1. Failed or broken overload spring. Replace spring if necessary.
2. No power to the drive motor/failed drive motor. Verify power and wiring connections to the motor. If necessary, replace the motor.
3. Pawl bar not properly installed. Verify that the pawl bar is installed correctly.

Problem: Racks go through the machine, but results are poor.

1. Verify that detergent is being dispensed into the machine at the appropriate quantities for the water volume. If not, get detergent to appropriate level and review results of washing ware.
2. Clogged strainers/scrap basket. Clean out strainers and scrap basket and replace.
3. Ware not being properly prescrapped. Review paragraph entitled "Ware Preparation" in Operating Instructions.
4. Wash or rinse arms missing end plugs or caps. Verify and replace as required.
5. Low tank heat.
6. Inadequate rinse.
7. Incorrect voltage coming to the machine. Verify that the voltage matches that on the machine data plate.
8. Wash pump cavitation due to low water level. Verify that the drains are shut and that the water level is correct.

Problem: Spotting of silverware, glasses and dishes.

1. Incorrect final rinse temperature. Verify that the rinse water temperature matches that which is listed on the machine data plate.
2. Clogged wash and/or rinse nozzles and arms. Remove the arms and verify that they and their nozzles are free from debris.
3. Excessively hard water. Install a water softener to reduce hardness.
4. Loss of water pressure due to clogged/obstructed wash pump. Turn the power off to the machine at the source. Drain the wash tank of water and verify that the pump intake is free from debris.
5. Improper scrapping procedures. Review the paragraph entitled "Ware Preparation" in Operating Instructions.
6. incorrect detergent/chemical concentrations. Verify that the detergent/chemical concentrations are correct for the associated water volume.

TORQUE SETTINGS

When replacing components either in the control box or the heater box area, the manufacturer has suggestions on how much to torque the screws and nuts used in securing items to the machine. Refer to the table below for the torque specifications:

<u>ITEMS</u>	<u>TORQUE SPEC</u>
Relays	16 In/lbs
Heater Contactor	35 In/lbs
Heater Nuts	16 In/lbs
Terminal Block	50 In/lbs

SECTION 4: TROUBLESHOOTING

D226 TROUBLESHOOTING SECTION



WARNING: Inspection, testing and repair of electrical equipment should be performed only by qualified service personnel. Certain procedures in this section require electrical tests or measurements while power is applied to the machine. **Exercise extreme caution at all times.** If test points are not easily accessible, disconnect power, attach test equipment and reapply power to test. When replacing electrical parts, disconnect power at source circuit breaker.

Problem: Power light does not illuminate.

1. Power not connected to the unit through the control box. Open the control box cover and verify that incoming power lines are connected and light.
2. Service breaker tripped or open. Verify that the breaker is closed.
3. Power switch connections could be loose. Ensure that the connections are of sound quality.
4. Power switch is faulty. Replace the power switch.
5. Power light is faulty. Replace the light.

Problem: Water pressure is too low.

1. Water pressure regulator is out of adjustment. Follow the instructions provided in the maintenance section and adjust so that the flow pressure is 20 ± 5 PSI.
2. Water pressure regulator internal strainer is clogged. Clean in accordance with the instructions provided in the maintenance section.
3. Water pressure regulator is faulty. Replace the regulator.
4. Water pressure gauge is faulty or the cut off from the system. Verify that the test cock valve under the gauge is open to allow for the sensing of line pressure. Replace gauge if necessary.
5. Heat exchanger is clogged. Replace the heat exchanger.

Problem: Solenoid valve is not opening/shutting.

1. Power not connected to the unit through the control box. Open the control box cover and verify that incoming power lines are connected and light.
2. Service breaker tripped or open. Verify that the breaker is closed.
3. Power switch connections could be loose. Ensure that the connections are of sound quality.
4. Power switch is faulty. Replace the power switch.
5. Thermostat is faulty. Replace the thermostat.
6. Solenoid wires are loose or broken. Verify that the electrical connections are of sound quality.
7. Faulty solenoid coil. Replace the solenoid.

Problem: Outlet water temperature too low.

1. Power not connected to the unit through the control box. Open the control box cover and verify that incoming power lines are connected and light.
2. Service breaker tripped or open. Verify that the breaker is closed.
3. Power switch connections could be loose. Ensure that the connections are of sound quality.
4. Power switch is faulty. Replace the power switch.
5. Thermostat is faulty. Replace the thermostat.
6. Solenoid wires are loose or broken. Verify that the electrical connections are of sound quality.
7. Faulty solenoid coil. Replace the solenoid.
8. Steam flow pressure is too low for the unit. Verify that the steam flow is 15-25 PSIG.
9. Water flow pressure is too high. Follow the instructions provided in the maintenance section and adjust so that the flow pressure is 20 ± 5 PSI.
10. Heat exchanger is clogged. Replace the heat exchanger.
11. Insufficient volume of steam to unit. Check the line size and flow pressure.

SECTION 5: PARTS SECTION

SECTION 5: PARTS SECTION
AJ-64 CONTROL BOX ASSEMBLY

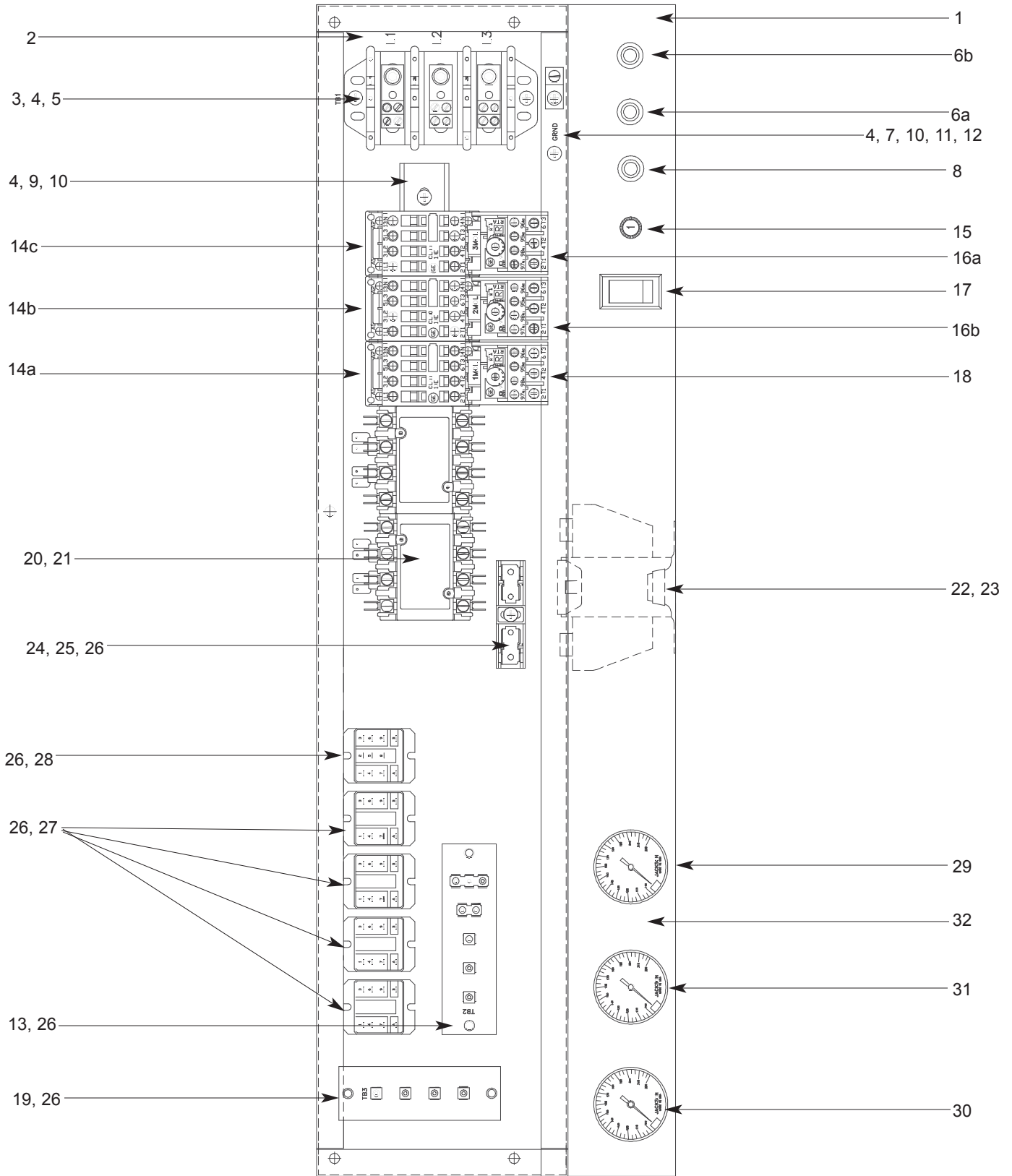

SECTION 5: PARTS SECTION
AJ-64 CONTROL BOX ASSEMBLY (CONTINUED)

ITEM	QTY	DESCRIPTION	Mfg. No.
1	1	Electrical Box Weldment	05700-041-88-50
2	1	Decal, L1-L2-L3	09905-101-12-66
3	1	Terminal Block	05940-011-48-27
4	6	Lockwasher, #10	05311-273-02-00
5	2	Screw, 10-32 x 3/4" Long Phillips Trusshead	05305-011-62-17
6a	1	Light, Amber (Wash Heater Overload) (Not used on steam or gas models)	05945-111-44-44
6b	1	Light, Amber (Rinse Heater Overload) (Not used on steam or gas models)	05945-111-44-44
7	1	Wire Lug, 2 AWG to 14 AWG	05940-200-76-00
8	1	Light, Red (Power)	05945-111-44-45
9	1	Din Rail	05700-021-72-75
10	3	Screw, 10-32 x 1/2" Long Phillips Trusshead	05305-011-39-36
11	1	Washer, Flat, 1/4"	05311-174-01-00
12	1	Decal, Ground	09905-011-86-86
13	1	Terminal Board	05940-002-78-97
14a	1	Drive Motor Contactor	05945-111-68-38
14b	1	Wash Pump Motor Contactor	05945-111-68-38
14c	1	Recirculating Rinse Pump Motor Contactor	05945-111-68-38
15	1	Circuit Breaker (208 & 230 volt models only)	05925-011-68-34
16a	1	Recirculating Rinse Pump Motor Overload (See motor overloads chart)	N/A
16b	1	Wash Pump Motor Overload (See motor overloads chart)	N/A
17	1	Switch, ON/FILL & OFF/DRAIN	05930-011-49-55
18	1	Drive Motor Overload (See motor overloads chart)	N/A
19	1	Terminal Board	05940-021-89-41
20	2	Heater Contactor (Not available on steam or gas models)	05945-002-24-70
21	2	Screw, 10-32 x 3/8" Long Phillips Trusshead	05305-173-12-00
22	1	Transformer	05950-011-68-35
23	4	Locknut, 10-24 with Nylon Insert	05310-373-01-00
24	1	Fuse Holder (460 volt models only)	05920-011-72-89
25	1	Fuse (460 volt models only)	05920-011-72-88
26	12	Screw, 6-32 x 3/8" Long Phillipshead	05305-171-02-00
27	4	Control Relay, 2 Pole	05945-111-35-19
28	1	Relay, 3 Pole	05945-111-72-51
29	1	Rinse Thermometer	06685-111-68-49
		Decal, Rinse 180°F	09905-002-97-62
30	1	Wash Thermometer	06685-111-87-13
		Decal, Wash 150°F	09905-002-97-61
31	1	Power Rinse Thermometer	06685-111-87-13
		Decal, Power Rinse 160°F	09905-003-01-31
32	1	Decal, Gauge	09905-021-82-65

Items not shown:

Grommet, 1/2" OD x 3/8" ID	05325-011-46-73
Bushing, Heyco SB100	05975-210-09-00
Plug, Heyco 2700 G-875	05975-011-47-81
Control Box Cover	05700-031-66-88
Control Box Cover Hinge Weldment	05700-021-68-57
Control Hinge Rod	05700-011-68-58
MANUAL/DELIME Switch (Located on rear of control box)	05930-301-22-18
MANUAL/DELIME Decal	09905-011-74-61
Copper Conductors Only Decal	09905-011-47-35
Control Box Leg	05700-011-71-47

SECTION 5: PARTS SECTION
AJ-86 & AJ-100 CONTROL BOX ASSEMBLY

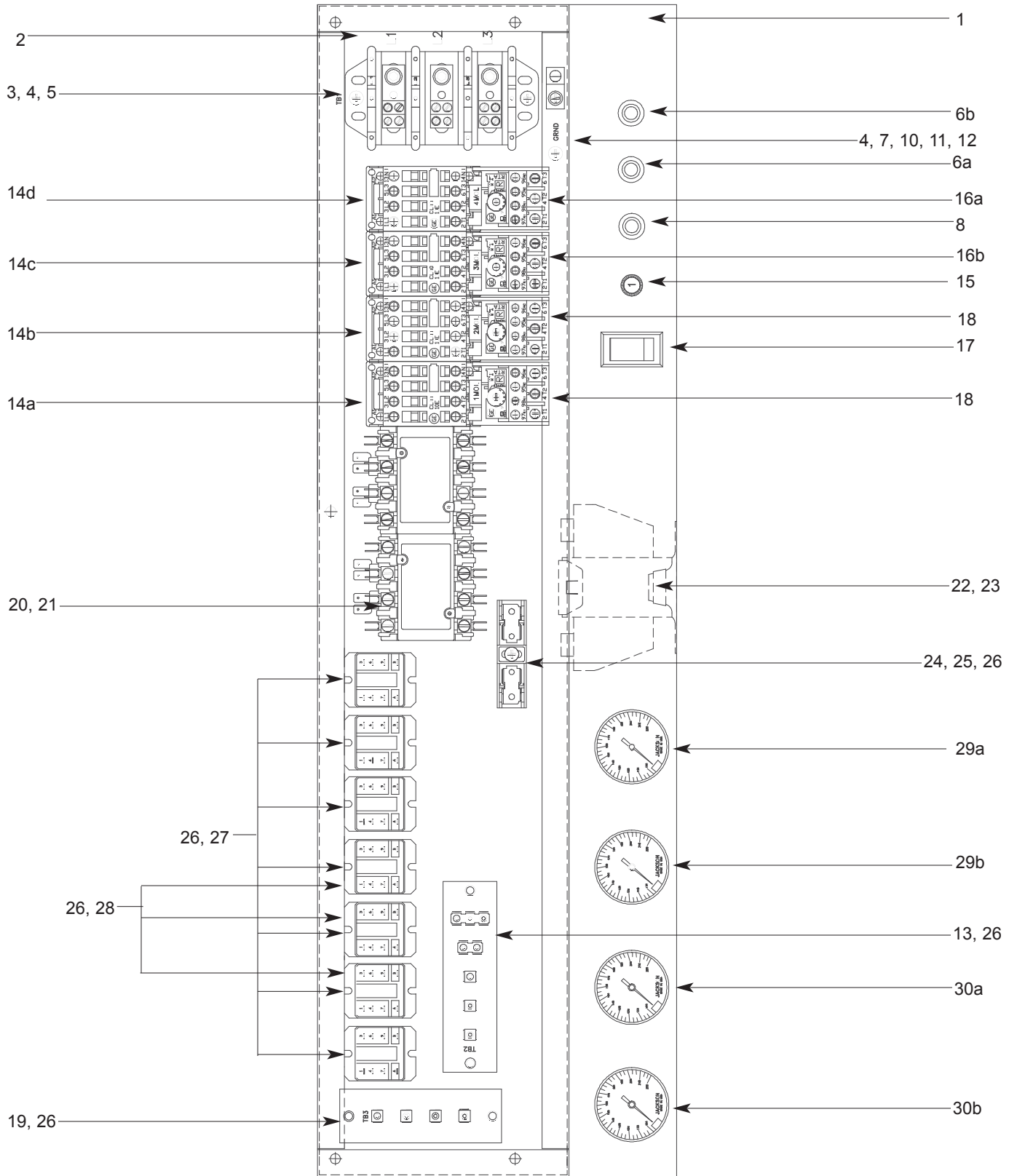

SECTION 5: PARTS SECTION

AJ-86 & AJ-100 CONTROL BOX ASSEMBLY (CONTINUED)

ITEM	QTY	DESCRIPTION	Mfg. No.
1	1	Electrical Box Weldment	05700-041-88-50
2	1	Decal, L1-L2-L3	09905-101-12-66
3	1	Terminal Block	05940-011-48-27
4	6	Lockwasher, #10	05311-273-02-00
5	2	Screw, 10-32 x 3/4" Long Phillips Trusshead	05305-011-62-17
6a	1	Light, Amber (Wash Heater Overload) (Not used on steam or gas models)	05945-111-44-44
6b	1	Light, Amber (Rinse Heater Overload) (Not used on steam or gas models)	05945-111-44-44
7	1	Wire Lug, 2 AWG to 14 AWG	05940-200-76-00
8	1	Light, Red (Power)	05945-111-44-45
9	1	Din Rail	05700-021-94-96
10	3	Screw, 10-32 x 1/2" Long Phillips Trusshead	05305-011-39-36
11	1	Washer, Flat, 1/4"	05311-174-01-00
12	1	Decal, Ground	09905-011-86-86
13	1	Terminal Board	05940-002-78-97
14a	1	Drive Motor Contactor	05945-111-68-38
14b	1	Wash Pump Motor Contactor	05945-111-68-38
14c	1	Recirculating Rinse Pump Motor Contactor	05945-111-68-38
14d	1	Prewash Pump Motor Contactor	05945-111-68-38
15	1	Circuit Breaker (208 & 230 volt models only)	05925-011-68-34
16a	1	Recirculating Rinse Pump Motor Overload (See motor overloads chart)	N/A
16b	1	Wash Pump Motor Overload (See motor overloads chart)	N/A
17	1	Switch, ON/FILL & OFF/DRAIN	05930-011-49-55
18	1	Drive Motor Overload (See motor overloads chart)	N/A
19	1	Terminal Board	05940-021-89-41
20	2	Heater Contactor (Not available on seam models)	05945-002-24-70
21	2	Screw, 10-32 x 3/8" Long Phillips Trusshead	05305-173-12-00
22	1	Transformer	05950-011-68-35
23	4	Locknut, 10-24 with Nylon Insert	05310-373-01-00
24	1	Fuse Holder (460 volt models only)	05920-011-72-89
25	1	Fuse (460 volt models only)	05920-011-72-88
26	12	Screw, 6-32 x 3/8" Long Phillipshead	05305-171-02-00
27	7	Control Relay, 2 Pole (5 for Gas models, 1 not shown)	05945-111-35-19
28	3	Relay, 3 Pole (Gas models only)	05945-111-72-51
29a	1	Rinse Thermometer, 96" (L-R & R-L models)	06685-111-68-49
		Decal, Rinse 180°F	09905-002-97-62
29b	1	Power Rinse Thermometer, 96" (L-R models)	06685-111-68-49
29b	1	Power Rinse Thermometer, 120" (R-L models)	06685-111-87-13
		Decal, Power Rinse 160°F	09905-003-01-31
30a	1	Wash Thermometer, 120" (L-R models)	06685-111-87-13
30a	1	Wash Thermometer, 96" (R-L models)	06685-111-68-49
		Decal, Wash 150°F	09905-002-97-61
30b	1	Prewash Thermometer, 120" (L-R & R-L models)	06685-111-87-13
31	1	Power Rinse Thermometer	06685-111-87-13
		Decal, Power Rinse 160°F	09905-003-01-31
32	1	Decal, Gauge	09905-021-82-65
Items not shown:			
		Grommet, 1/2" OD x 3/8" ID	05325-011-46-73
		Bushing, Heyco SB100	05975-210-09-00
		Plug, Heyco 2700 G-875	05975-011-47-81
		Control Box Cover	05700-031-66-88
		Control Box Cover Hinge Weldment	05700-021-68-57
		Control Hinge Rod	05700-011-68-58
		MANUAL/DELIME Switch (Located on rear of control box)	05930-301-22-18
		MANUAL/DELIME Decal	09905-011-74-61
		Copper Conductors Only Decal	09905-011-47-35
		Control Box Leg	05700-011-71-47

SECTION 5: PARTS SECTION
MOTOR OVERLOADS

AJ-64 SERIES MOTOR OVERLOAD CHART:

	<u>208-230V/60 HZ/1 PHASE</u>	<u>208-230V/60 HZ/3 PHASE</u>	<u>460V/60 HZ/3 PHASE</u>
Drive Motor	Not Applicable	05945-111-68-39	05945-111-69-12
PreWash Motor	Not Applicable	Not Applicable	Not Applicable
Wash Motor	Not Applicable	05945-111-68-40	05945-111-68-41
Power Rinse Motor	Not Applicable	05945-111-68-40	05945-111-68-41

AJ-86 SERIES MOTOR OVERLOAD CHART:

	<u>208-230V/60 HZ/1 PHASE</u>	<u>208-230V/60 HZ/3 PHASE</u>	<u>460V/60 HZ/3 PHASE</u>
Drive Motor	Not Applicable	05945-111-68-39	05945-111-69-12
PreWash Motor	Not Applicable	05945-111-68-41	05945-111-69-13
Wash Motor	Not Applicable	05945-111-68-40	05945-111-68-41
Power Rinse Motor	Not Applicable	05945-111-68-40	05945-111-68-41

AJ-100 SERIES MOTOR OVERLOAD CHART:

	<u>208-230V/60 HZ/1 PHASE</u>	<u>208-230V/60 HZ/3 PHASE</u>	<u>460V/60 HZ/3 PHASE</u>
Drive Motor	Not Applicable	05945-111-68-39	05945-111-69-12
PreWash Motor	Not Applicable	05945-111-68-40	05945-111-68-41
Wash Motor	Not Applicable	05945-111-68-40	05945-111-68-41
Power Rinse Motor	Not Applicable	05945-111-68-40	05945-111-68-41

SECTION 5: PARTS SECTION
HEATER BOX ASSEMBLY

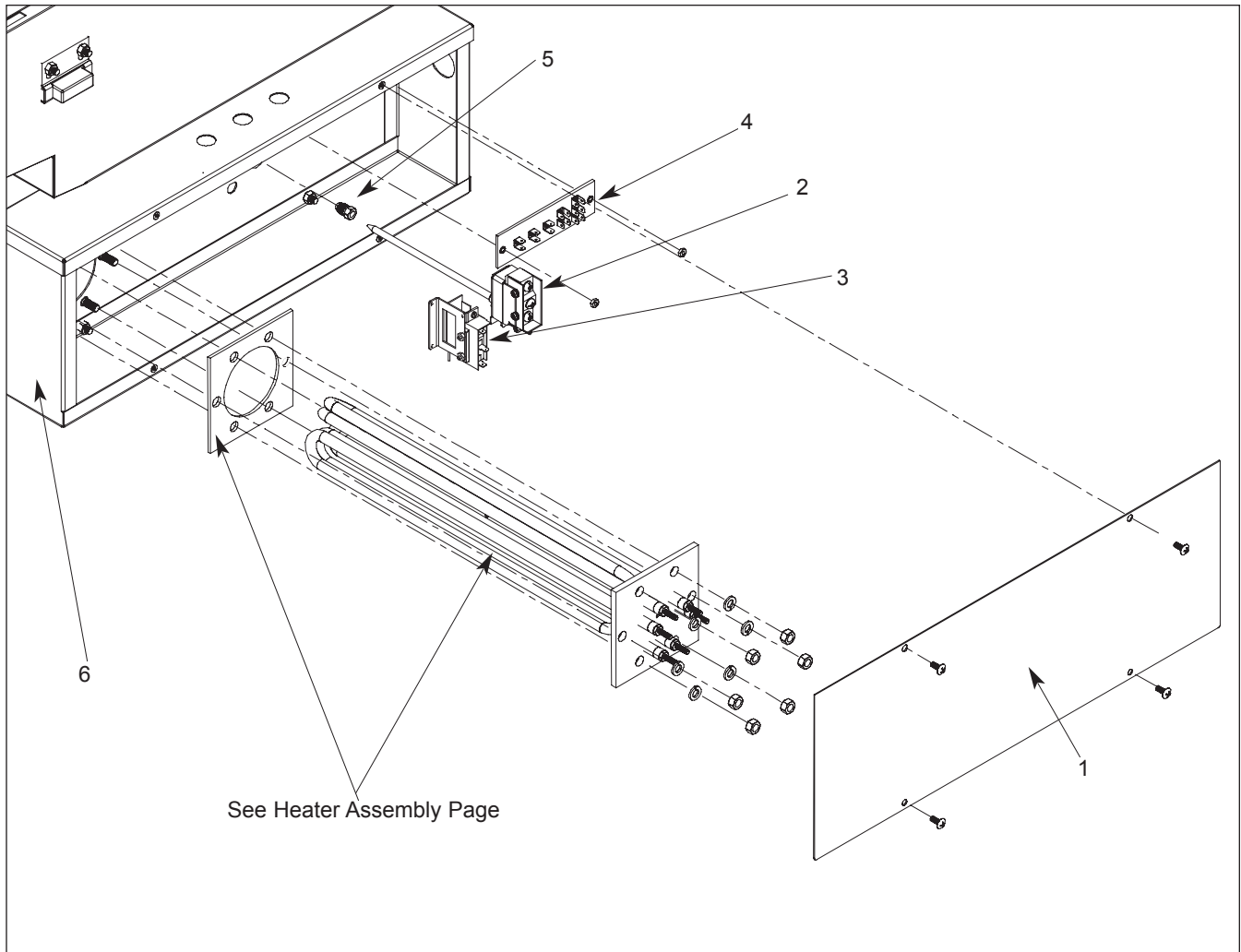

ITEM	QTY	DESCRIPTION	Mfg. No.
1	1	Heater Box Cover	05700-031-81-61
2	1	Kit, Thermostat, Wash Regulating (Electrically Heated)	06401-003-18-20
3	1	Kit, Thermostat, Wash Regulating (Steam Heated)	06401-003-18-21
4	1	Thermostat, High Limit	05930-011-49-43
5	1	Terminal Board	05940-002-78-97
6	1	Fitting, 1/4", Imperial Brass	05310-924-02-05
6	1	Heater Box Weldment	05700-002-41-18

SECTION 5: PARTS SECTION

HEATER ASSEMBLY

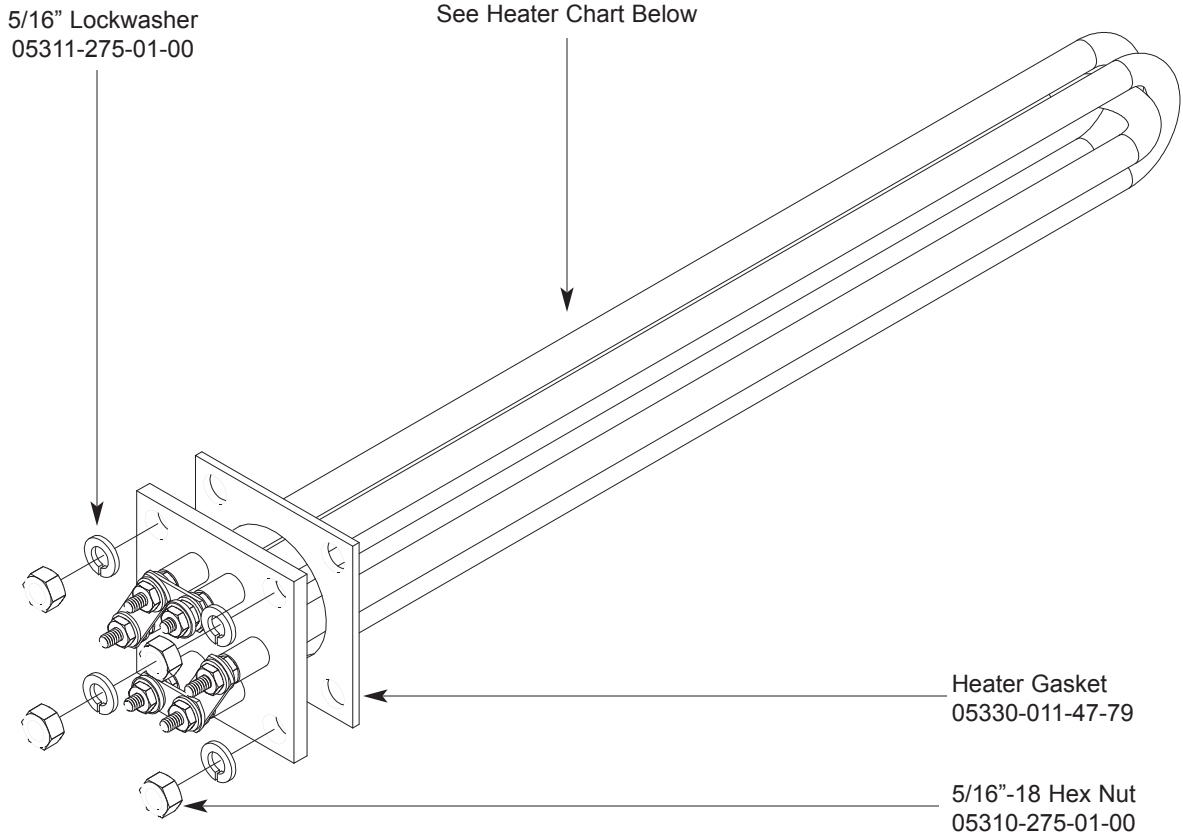

Heater Chart

<u>Model</u>	<u>Volts</u>	<u>Phase</u>	<u>KW</u>	<u>Part Number</u>
All*	208	1	10	06401-003-12-94
	230	1	10	06401-003-12-95
	208	3	10	06401-003-12-94
	230	3	10	06401-003-12-95
	460	3	10	06401-003-12-96

Heater Chart

<u>Model</u>	<u>KW</u>	<u>208V Models</u>	<u>230V Models</u>	<u>460V Models</u>
All*	15	04540-121-68-45	04540-121-68-46	04540-121-68-47

* - "CS" & "CGP" models do not use electric heaters in the wash tank or power rinse tank.

SERVICE NOTE: When replacing the tub heaters, it is HIGHLY recommended that you also change out the gasket as well. Once installed, gaskets become compressed and are subjected to extreme temperature changes. Replacing the gasket with a new one when replacing the heater may prevent future leaks.

SERVICE NOTE: The nuts used to secure the heater to the tub should be torqued to 16 in-lbs. After tightening, the unit should be allowed to heat up and operate normally for approximately 30 minutes. Secure power to the machine and check the nuts once more to ensure that they are torqued to 16 in-lbs.

SECTION 5: PARTS SECTION

HEATER ASSEMBLY (CONTINUED)

The wash tank heater system is electrically connected in the circuit so that they are dependent upon the dishwasher being properly filled with and maintaining a safe water level, two thermostats (mounted in the heater box behind the dress panel), float switch (mounted in the wash tank), and the heater relay (mounted in control box) with the heater being activated by the thermostats.

Once the dishwasher has been filled to the correct level, the heater should operate automatically. Should the tank heat be too high, too low or no indication of temperatures at all, the following checkout should be made.

Note: The following checkout should be made by either a qualified service person or electrician.

A- Checkout of the heater system

- 1- If the temperature is too high, adjust thermostat using instructions on the page entitled "Thermostats".
- 2- If temperature is too low, adjust thermostat as above, then:
 - a - Turn off power to machine by placing customer's circuit breaker in the "OFF" position. Turn off machine circuit breaker located on right side of control box.
 - b - Remove cover from control box on top of dishwasher.
 - c - Make sure water temperature is below 140° F.(preferably about 130°F.).
 - d - Turn on both circuit breakers. Observe heater relay (R1) while the power switch is turned "ON" and "OFF". If relay contacts move in and out, the heater relay is operating correctly: if not proceed to "C".

B- If heater relay (R1) closes:

- 1 - Check power supply at incoming terminal board L1, L2 & L3. It should be the same voltage as indicated on the machine data plate.
- 2 - Check power at connections on heater relay (R1). The voltage should agree with the voltage on the machine data plate. If not, check wires for breaks or bad connections.
- 3 - Check power at terminals of heater which should agree with the data plate. If not check wires for breaks or bad connections.
- 4 - Temperatures should rise as explained in "C-1", and amperage may be checked according to those instructions. Replace any defective elements.

C - If heater relay (R1) does not close.

- 1 - There is an insulated movable insulated movable bar on relay across the top. With an insulated probe, depress this bar and observe the thermometer: the temperature should rise noticeably in a minute or two. If it moves slowly, it would indicate that the element is faulty. If it moves constantly higher at a good rate, elements should be good.

Note: A check with an amp probe at heater relay (R1) terminals should be made to verify the amp draw on each leg. This should be appropriate for the voltage and phase indicated on the data plate

HEATER PROTECTION & AUTOMATIC FILL

This control is activated when the power switch is turned "ON". The primary function is to automatically energize the wash tank heat circuit. It will also cutoff the wash tank heat circuit should the water be accidentally drained from the machine with the power switch still "ON". The power switch should always be turned-off before draining the unit.

This water level control consists of two (2) floats that operate when the power switch is turned on and works in conjunction with the thermostats and heater relays.

When the power switch is turned "ON" water starts to enter the dishmachine. When it reaches the proper level the normally open contacts in the water level float switch close activating the heating circuit for tank heat.

If the water level below the correct level while power is still on, the float switch will sense the lack of water and de-activate the heater.

SECTION 5: PARTS SECTION
FRAME WELDMENTS/DRESS PANELS

FRAME WELDMENTS

<u>Model</u>	<u>Left to Right Part Number</u>	<u>Right to Left Part Number</u>
AJ-64's	05700-002-73-00	05700-002-73-00
AJ-86's	05700-041-83-65	05700-041-83-65
AJ-86CGP	05700-041-83-65	05700-041-83-65
AJ-100's	05700-041-91-00	05700-041-91-00
AJ-100CGP	05700-041-91-00	05700-041-91-00

Bullet Feet (4 per model) - order using part number 05340-011-71-74.

FRONT DRESS PANELS

<u>Model</u>	<u>Left to Right Part Number</u>	<u>Right to Left Part Number</u>
AJ-64's	05700-002-40-41	05700-002-40-41
AJ-86's	05700-031-83-68	05700-041-86-60
AJ-86CGP	05700-002-89-68	05700-041-86-60
AJ-100's	05700-041-94-89	05700-041-91-06
AJ-100CGP	05700-041-94-89	05700-041-91-06

SECTION 5: PARTS SECTION
PREWASH PLUMBING ASSEMBLY

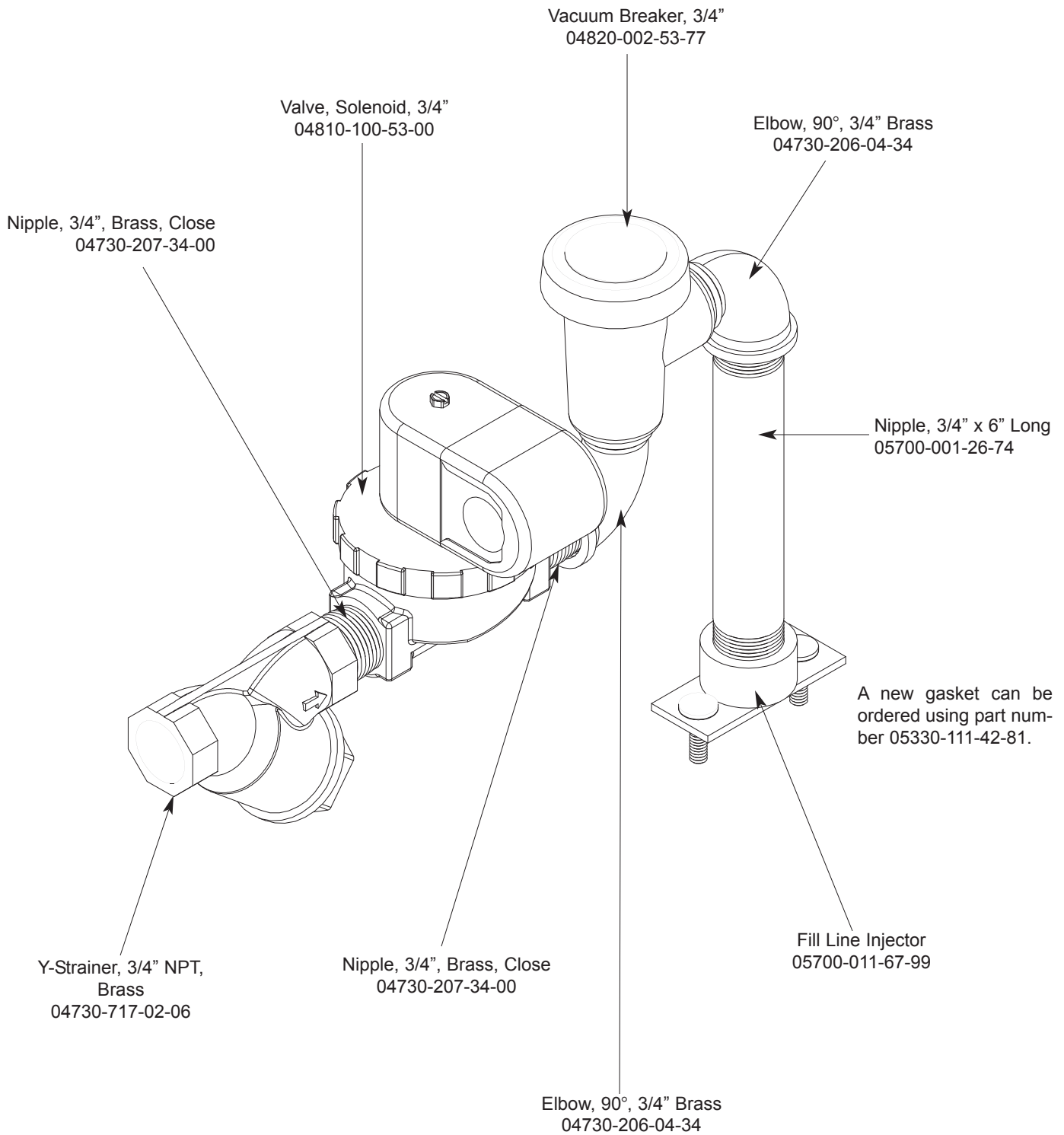

SECTION 5: PARTS SECTION

INCOMING PLUMBING ASSEMBLY (ELECTRIC & GAS HEATED MODELS)

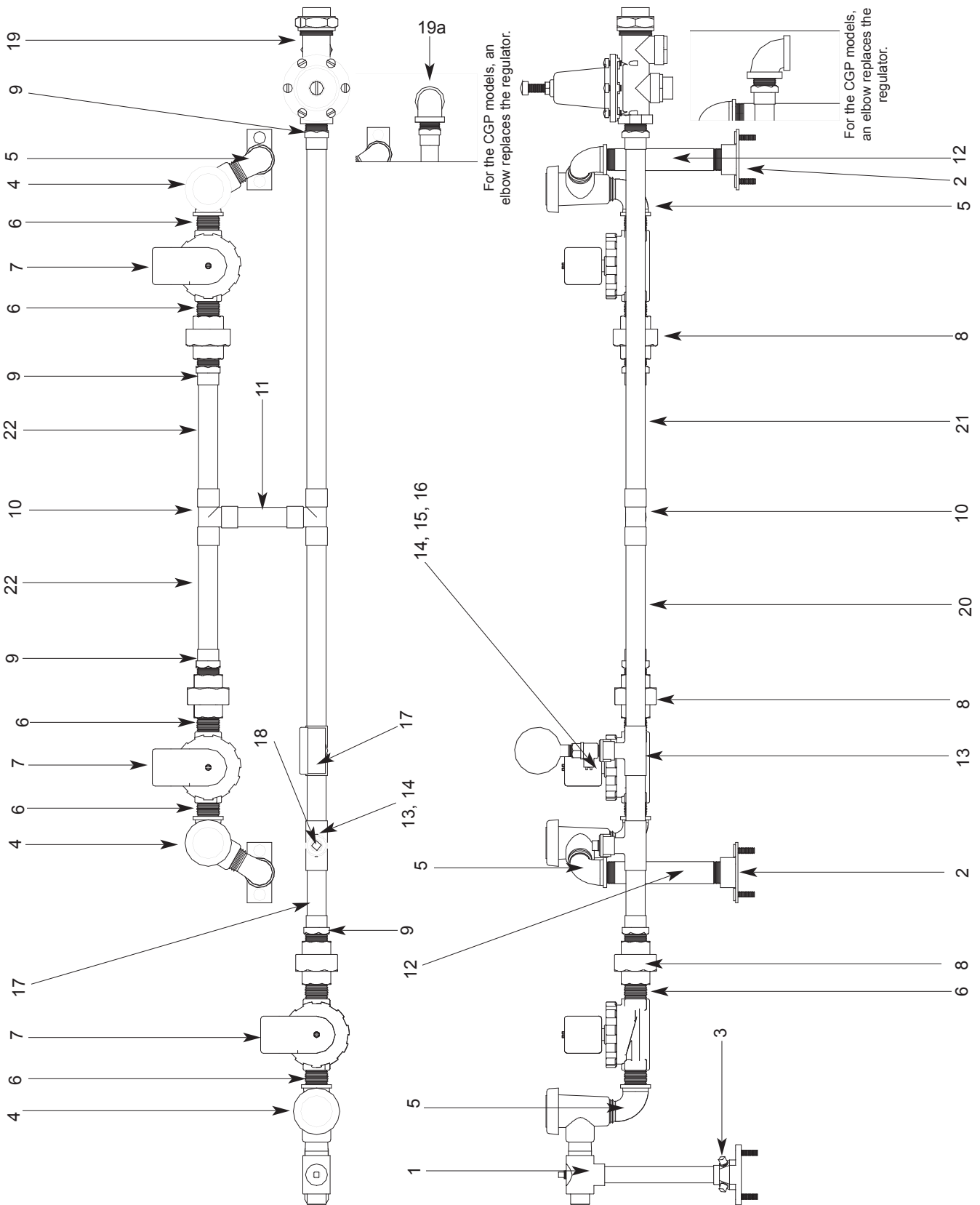

SECTION 5: PARTS SECTION
INCOMING PLUMBING ASSEMBLY(CONTINUED)

ITEM	QTY	DESCRIPTION	Mfg. No.
1	1	Injector, Rinse Weldment (L-R all units)	05700-021-67-98
1	1	Injector, Rinse Weldment (R-L CGP units only)	05700-002-57-87
2	2	Fill Line, Injector	05700-011-67-99
3	3	Plug, 1/8" NPT, Brass	04730-209-07-37
4	3	Vacuum Breaker, 3/4" NPT, Brass	04820-002-53-77
5	5	Elbow, 3/4" NPT, Street, Brass	04730-206-04-34
6	6	Nipple, 3/4" NPT, Close, Brass	04730-207-34-00
7	3	Valve, Solenoid, 3/4" NPT, 110 Volt	04810-100-53-00
8	3	Union, 3/4" NPT, Brass	04730-212-05-00
9	4	Adapter, 3/4" Male	04730-401-11-01
10	2	Tee, Copper, 3/4" CU x CU x CU	04730-411-46-01
11	1	Tube, Copper, 3/4" x 3" Long	05700-000-54-85
12	2	Nipple, 3/4" NPT, Brass, 6" Long	05700-001-26-74
13	2	Tee, Copper, 3/4" x 3/4" x 1/2"	04730-411-03-01
14	2	Adapter, Threaded, 1/4"	04730-401-41-01
15	1	Valve, Ball, Test Cock, 1/4" NPT	04810-011-72-67
16	1	Gauge, 0-100 PSI	06685-111-88-34
	1	Decal, 15-25 PSI	09905-002-97-74
17	2	Tube, 3/4" x 2-13/16" Long	05700-011-72-72
18	1	Plug, 1/4"	04730-209-01-00
19	1	Regulator, Pressure, 3/4" NPT (Not used on CGP models)	06685-011-58-22
19a	1	Elbow, 3/4" 90° Brass (Used on CGP models only)	04730-206-13-00
20	1	Tube, 3/4" x 9" Long	05700-000-75-61
21	1	Tube, 3/4" x 16-1/4" Long	05700-011-31-48
22	2	Tube, 3/4" x 5-1/2" Long	05700-002-61-46

SECTION 5: PARTS SECTION
RINSE HEADER PLUMBING ASSEMBLY (CGP MODELS)

Complete Plumbing Assembly
05700-002-51-16

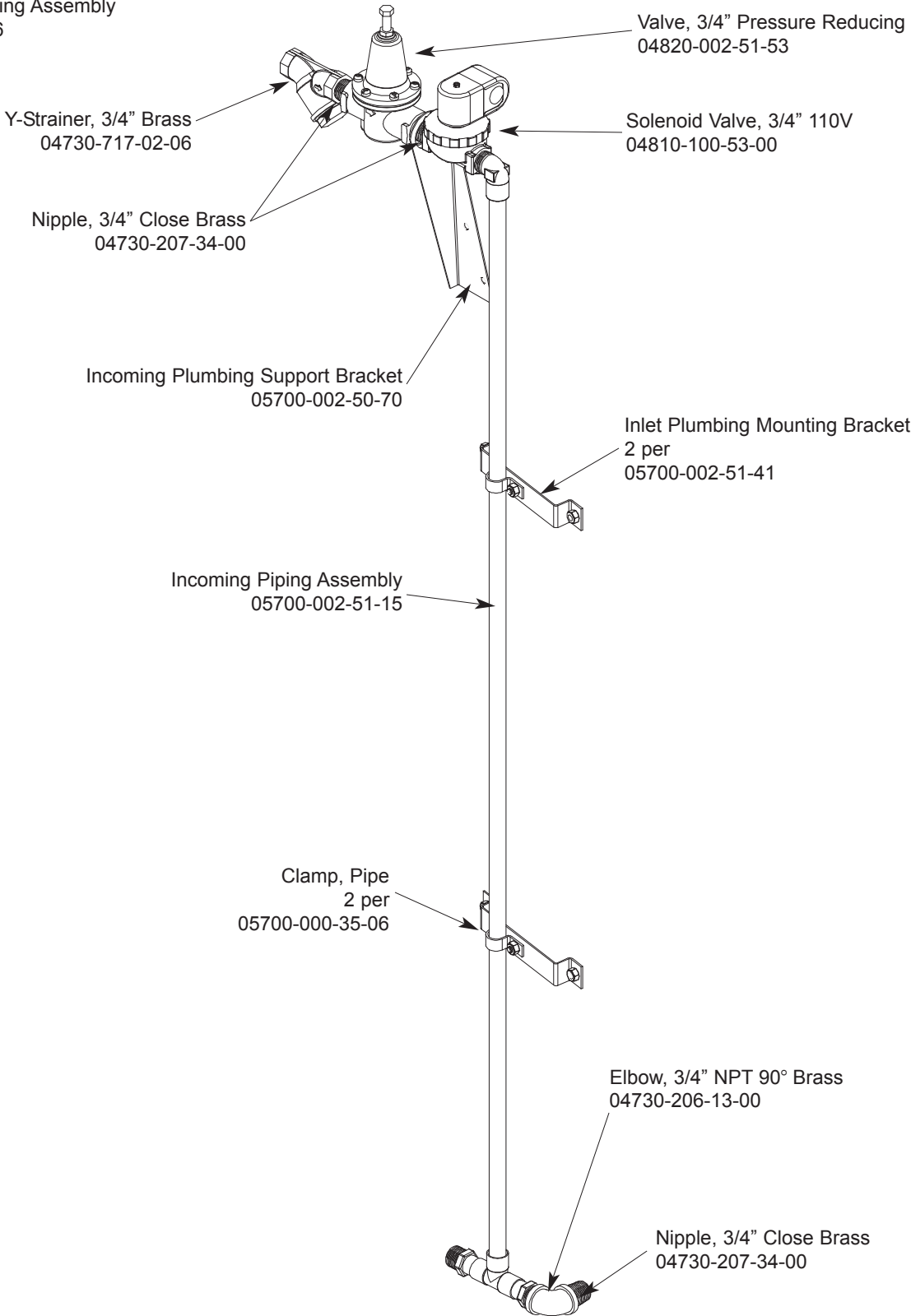

SECTION 5: PARTS SECTION

EXTERNAL ELECTRIC BOOSTER INCOMING PLUMBING ASSEMBLIES

Plumbing with Water Hammer Arrestor

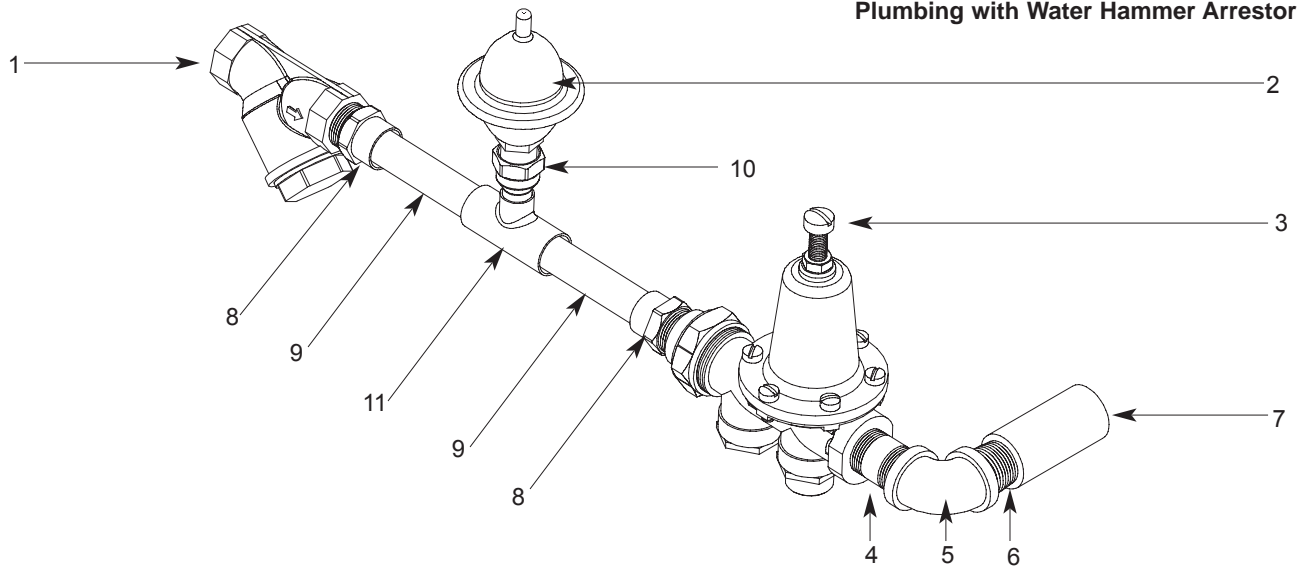

Plumbing without Water Hammer Arrestor

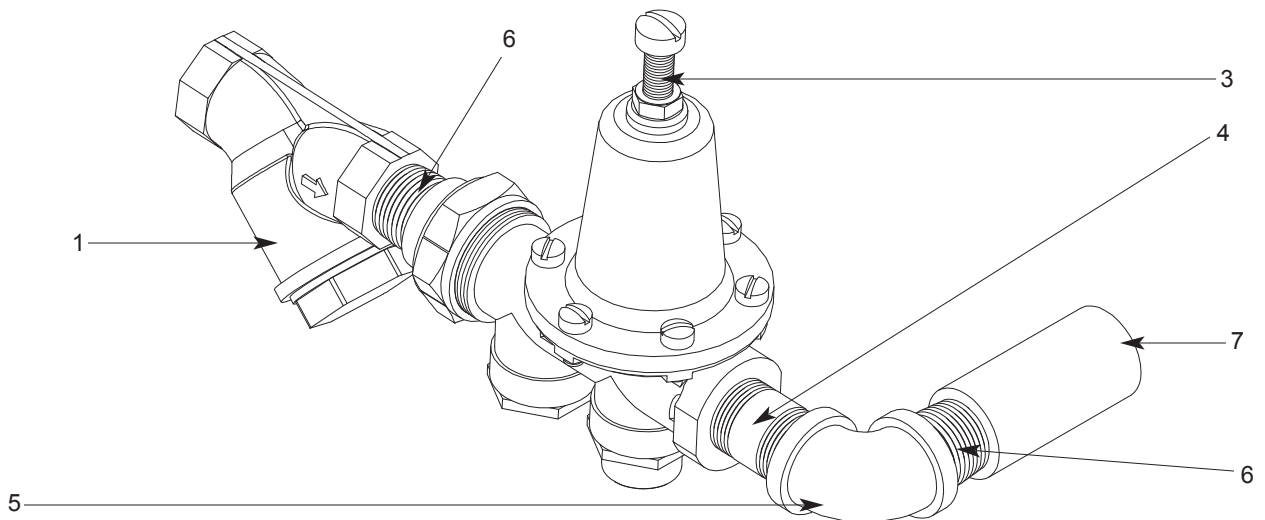

ITEM	QTY	DESCRIPTION	Mfg. No.
1	-	Y-Strainer, 3/4" NPT, Brass	04730-717-02-06
2	-	Arrestor, Water Hammer, 1/2" NPT	06685-100-05-00
3	-	Regulator, Pressure, 3/4" NPT, Brass	06685-011-58-22
4	-	Nipple, 3/4" NPT x 2" Long, Brass	04730-207-46-00
5	-	Elbow, Brass, 90°, 3/4"	04730-206-13-00
6	-	Nipple, 3/4" NPT, Close, Brass	04730-207-34-00
7	-	Coupling, 3/4" FNPT x 3/4" FNPT, Brass	04730-011-87-95
8	-	Adapter, 3/4" Male	04730-401-11-01
9	-	Tube, Copper, 3/4" x 3-7/16" Long	05700-011-72-70
10	-	Adapter, 1/2" NPT x Male	04730-401-07-01
11	-	Tee, Copper, 3/4" x 3/4" x 1/2"	04730-411-03-01

SECTION 5: PARTS SECTION
EXTERNAL ELECTRIC BOOSTER OPTION OUTLET PLUMBING

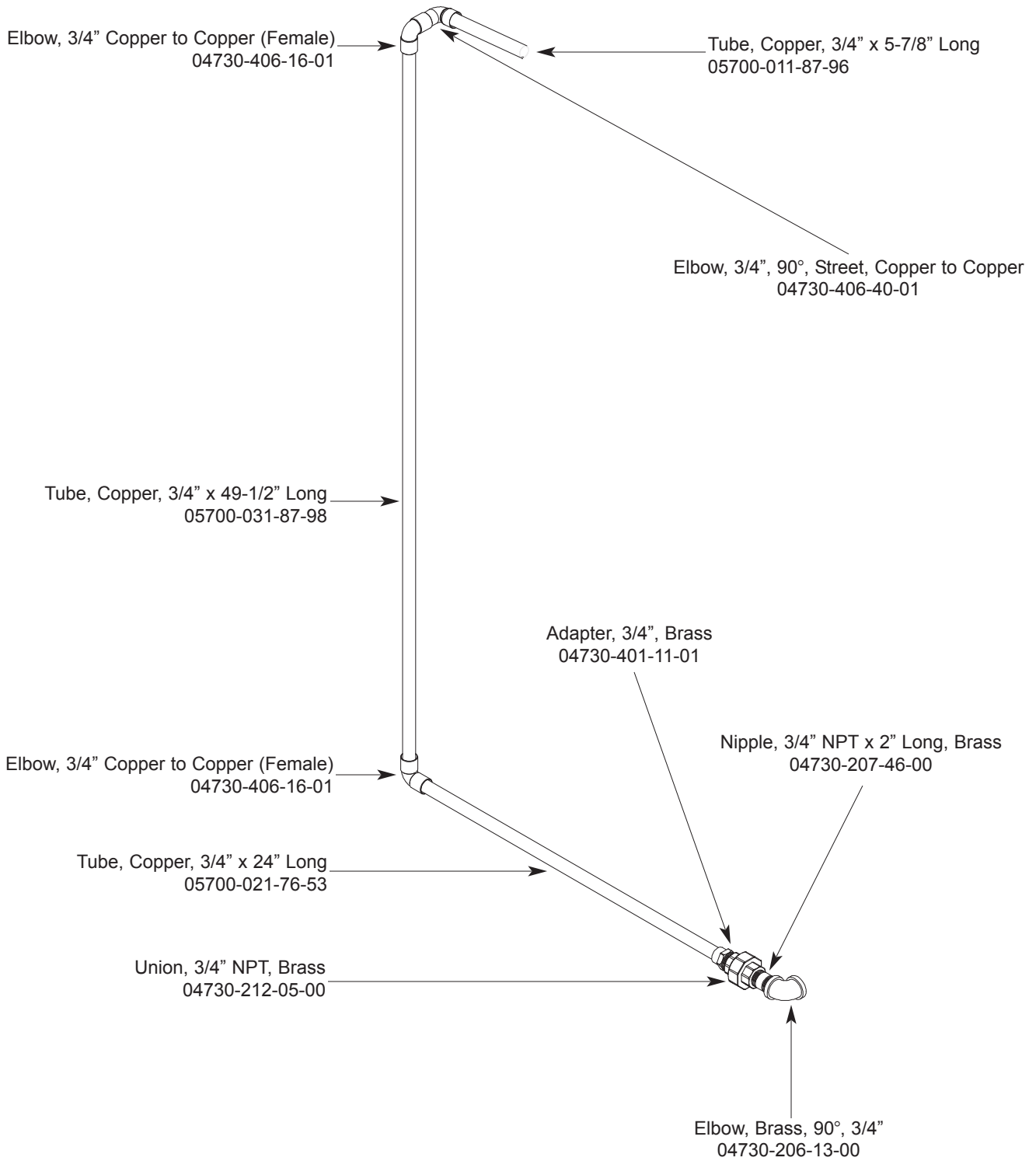

SECTION 5: PARTS SECTION

WATER HAMMER ARRESTOR OPTION/WATER PRESSURE REGULATOR KIT OPTION

WATER HAMMER ARRESTOR OPTION

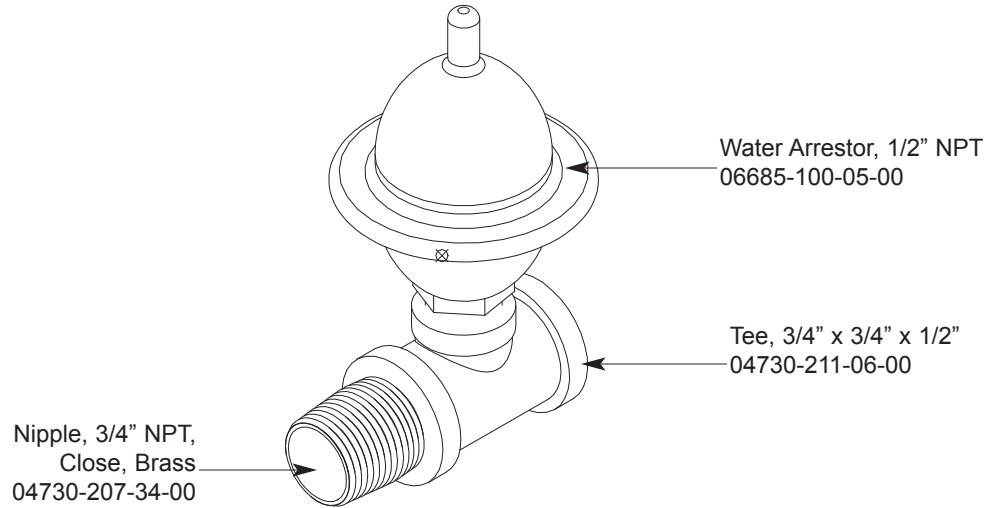

WATER PRESSURE REGULATOR WITH ARRESTOR KIT OPTION

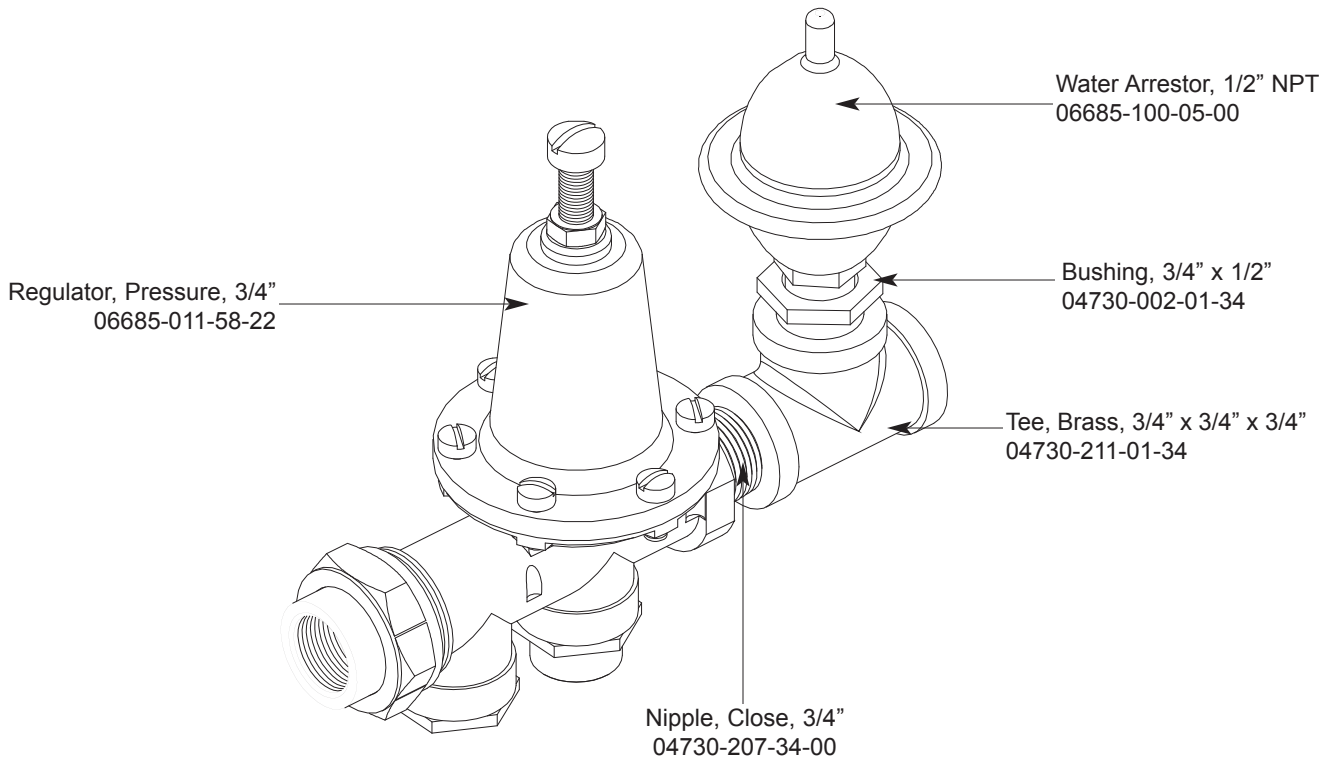

SECTION 5: PARTS SECTION

RINSE SOLENOID VALVE & VACUUM BREAKER REPAIR PARTS KITS

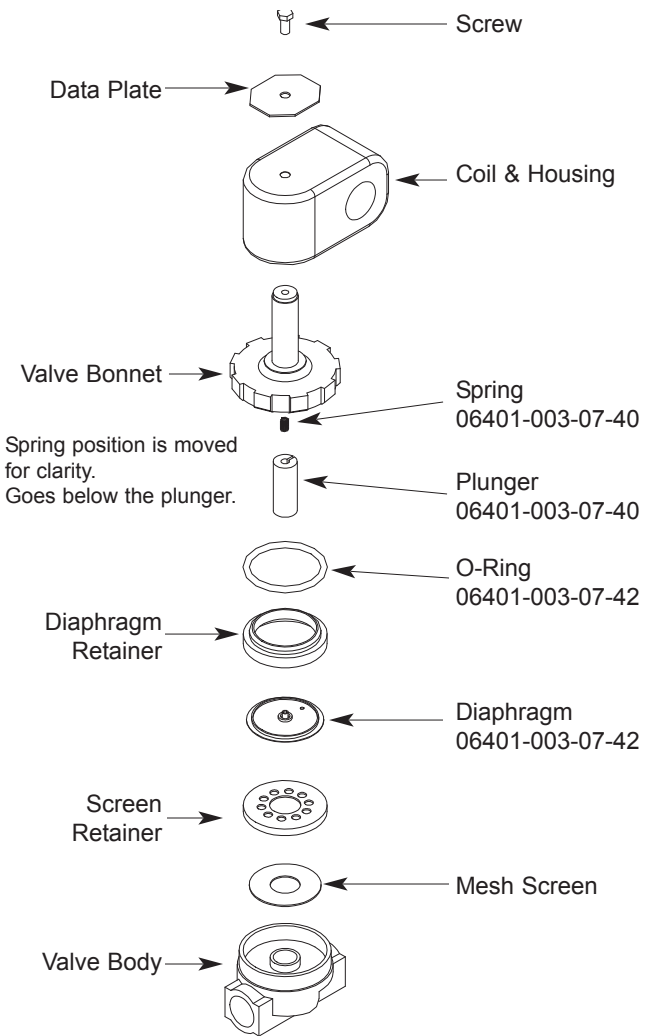

Complete 110 Volt Solenoid Valve Assembly, 3/4"
04810-100-53-00

Coil & Housing only, 3/4"
04810-200-01-18

Possible Problems:

1. Pilot port extension #1 clogged. Clean hole.
2. Hole #2 Clogged. Pass heated straight pin through hole.

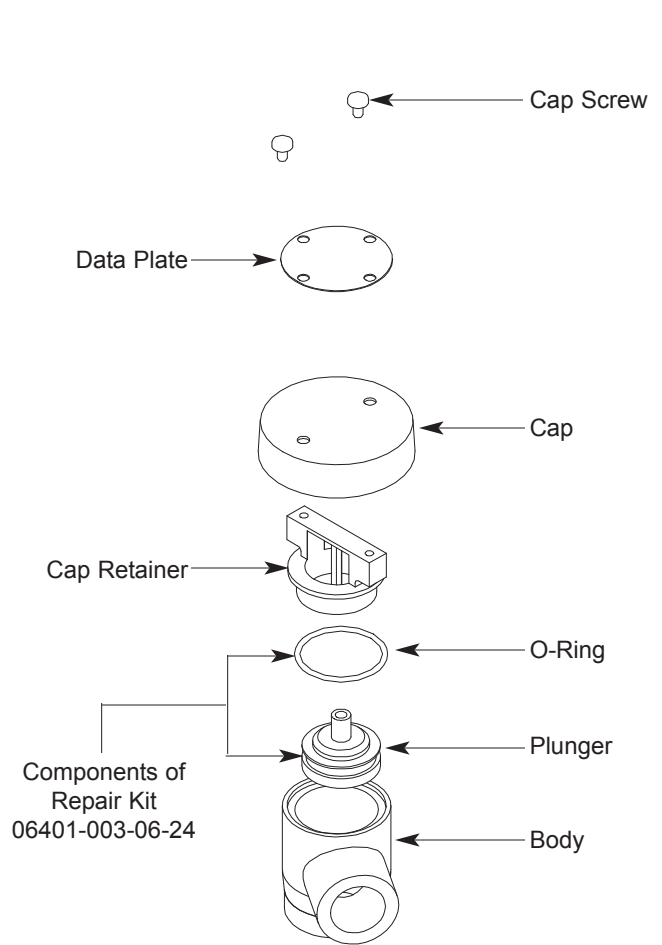
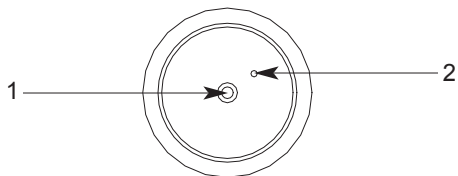

Complete Vacuum Breaker Assembly, 3/4" NPT
04820-002-53-77

DISASSEMBLY - These valves may be taken apart by unscrewing the bonnet and the enclosing tube assembly from the valve body assembly. After unscrewing, carefully lift off the bonnet and enclosing tube assembly. Don't drop the plunger. The o-ring seal and diaphragm cartridge can now be lifted out. Be careful not to damage the machined faces while the valve is apart.

TO REASSEMBLE - Place the diaphragm cartridge in the body with the pilot port extension UP. Hold the plunger with the synthetic seat against the pilot port. Make sure the o-ring is in place, then lower the bonnet and enclosing tube assembly over the plunger. Screw the bonnet assembly snugly down on the body assembly.

SECTION 5: PARTS SECTION

WASH TANK COIL ASSEMBLY

**WASH TANK COIL ASSEMBLY
(LEFT TO RIGHT) (05700-041-88-31)**

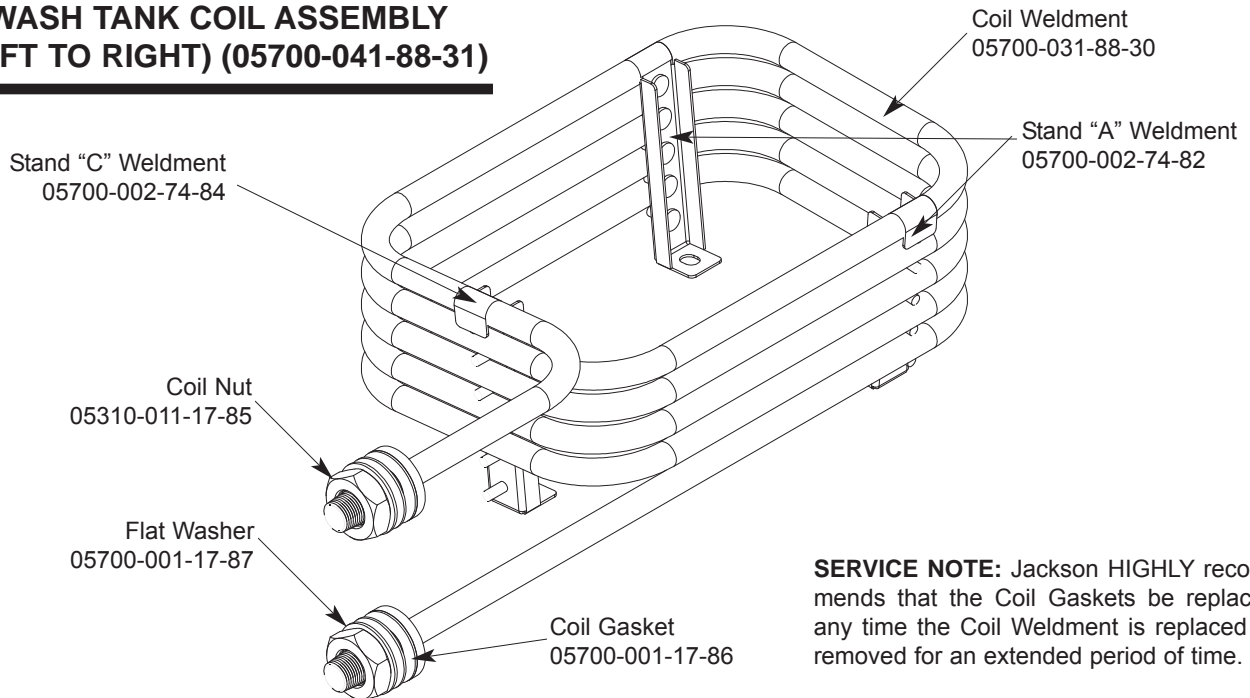

SERVICE NOTE: Jackson HIGHLY recommends that the Coil Gaskets be replaced any time the Coil Weldment is replaced or removed for an extended period of time.

**WASH TANK COIL ASSEMBLY
(RIGHT TO LEFT) (05700-002-81-44)**

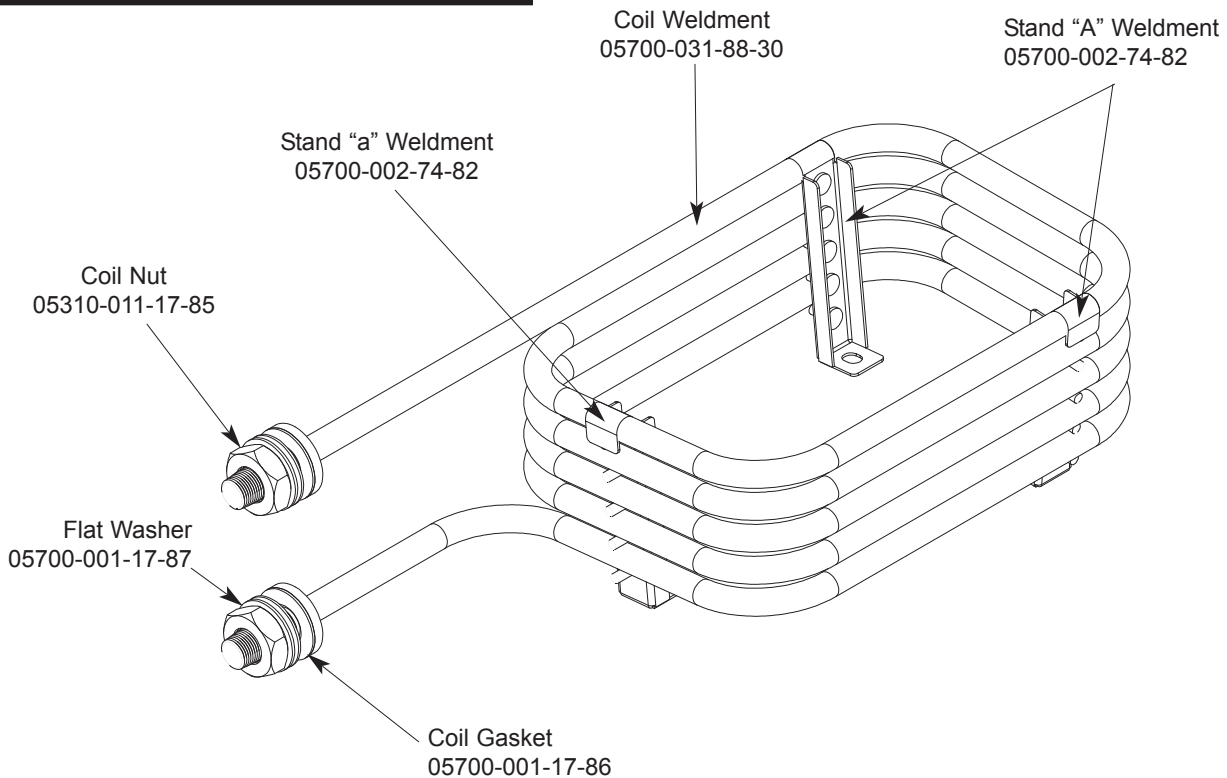

SECTION 5: PARTS SECTION
STEAM INLET PLUMBING ASSEMBLY (LEFT TO RIGHT MODELS)

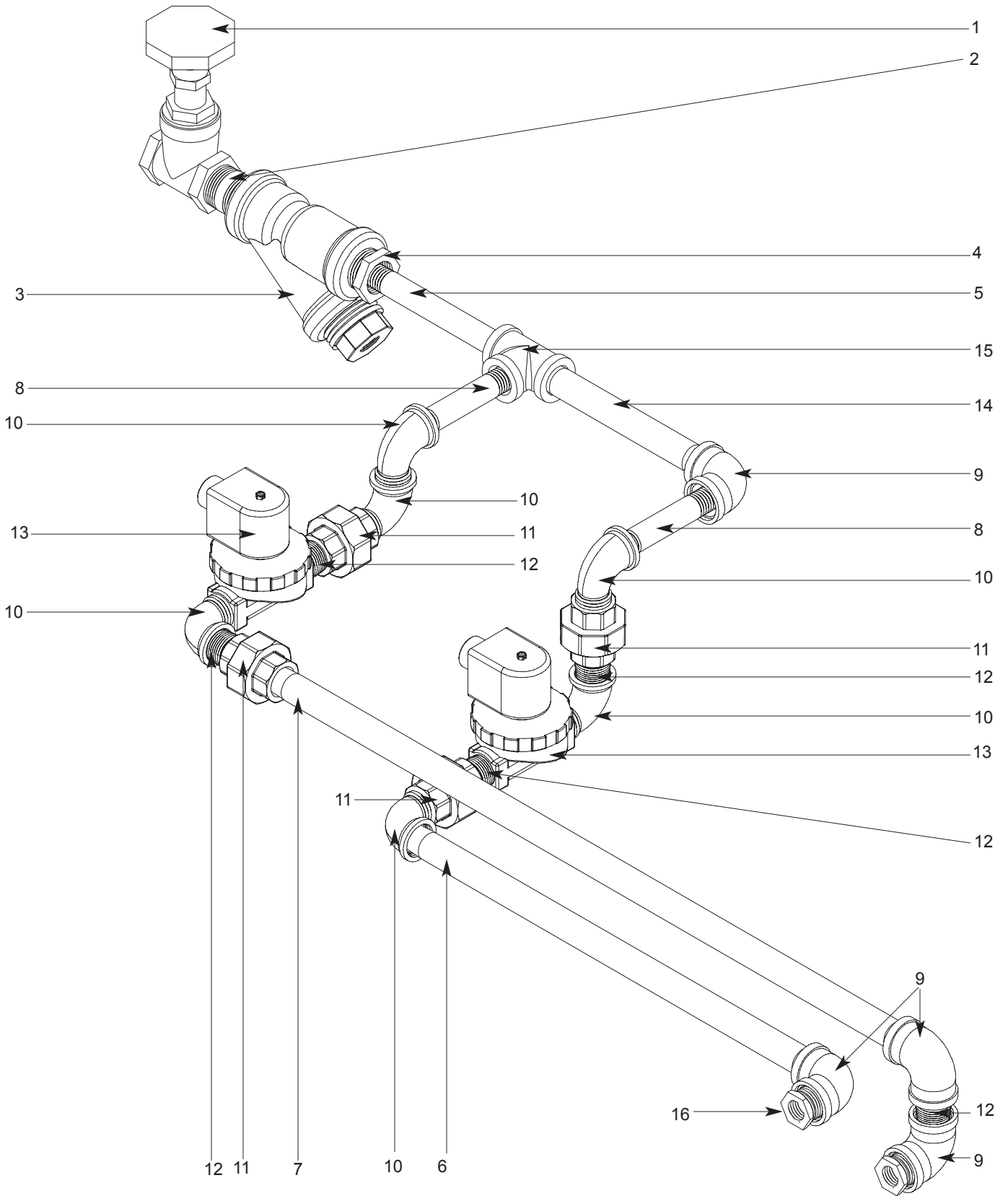

SECTION 5: PARTS SECTION

STEAM INLET PLUMBING ASSEMBLY (LEFT TO RIGHT MODELS) (CONTINUED)

ITEM	QTY	DESCRIPTION	Mfg. No.
1	1	Valve, 1" Gate, Steam	04820-011-87-30
2	1	Nipple, 1" NPT, Close, Black Iron	04730-907-08-34
3	1	Y-Strainer, 1" NPT, Black Iron	04730-217-02-32
4	1	Reducer, 1" to 3/4"	04730-011-95-66
5	1	Nipple, 3/4" NPT x 6" Long, Black Iron	04730-907-01-34
6	1	Nipple, 3/4" NPT x 17" Long, Black Iron	05700-002-74-16
7	1	Nipple, 3/4" NPT x 26-1/2" Long, Black Iron	05700-002-74-17
8	2	Nipple, 3/4" NPT x 2" Long, Black Iron	04730-907-02-34
9	4	Elbow, 90°, 3/4" NPT, Black Iron	04730-906-10-34
10	6	Elbow, 90°, 3/4" NPT, Street, Black Iron	04730-011-87-37
11	4	Union, 3/4" NPT, Black Iron	04730-912-01-00
12	5	Nipple, Close, 3/4" NPT, Black Iron	04730-907-04-00
13	2	Valve, Solenoid, Steam, 120V, 3/4" NPT	04820-011-87-39
14	1	Nipple, 3/4" NPT x 7" Long, Black Iron	05700-002-74-15
15	1	Tee, 3/4" NPT x 3/4" NPT x 3/4" NPT, Black Iron	04730-002-74-14
16	2	Reducer, 3/4" NPT to 1/2" NPT, Black Iron	04730-911-02-34

SECTION 5: PARTS SECTION
STEAM INLET PLUMBING ASSEMBLY (RIGHT TO LEFT MODELS)

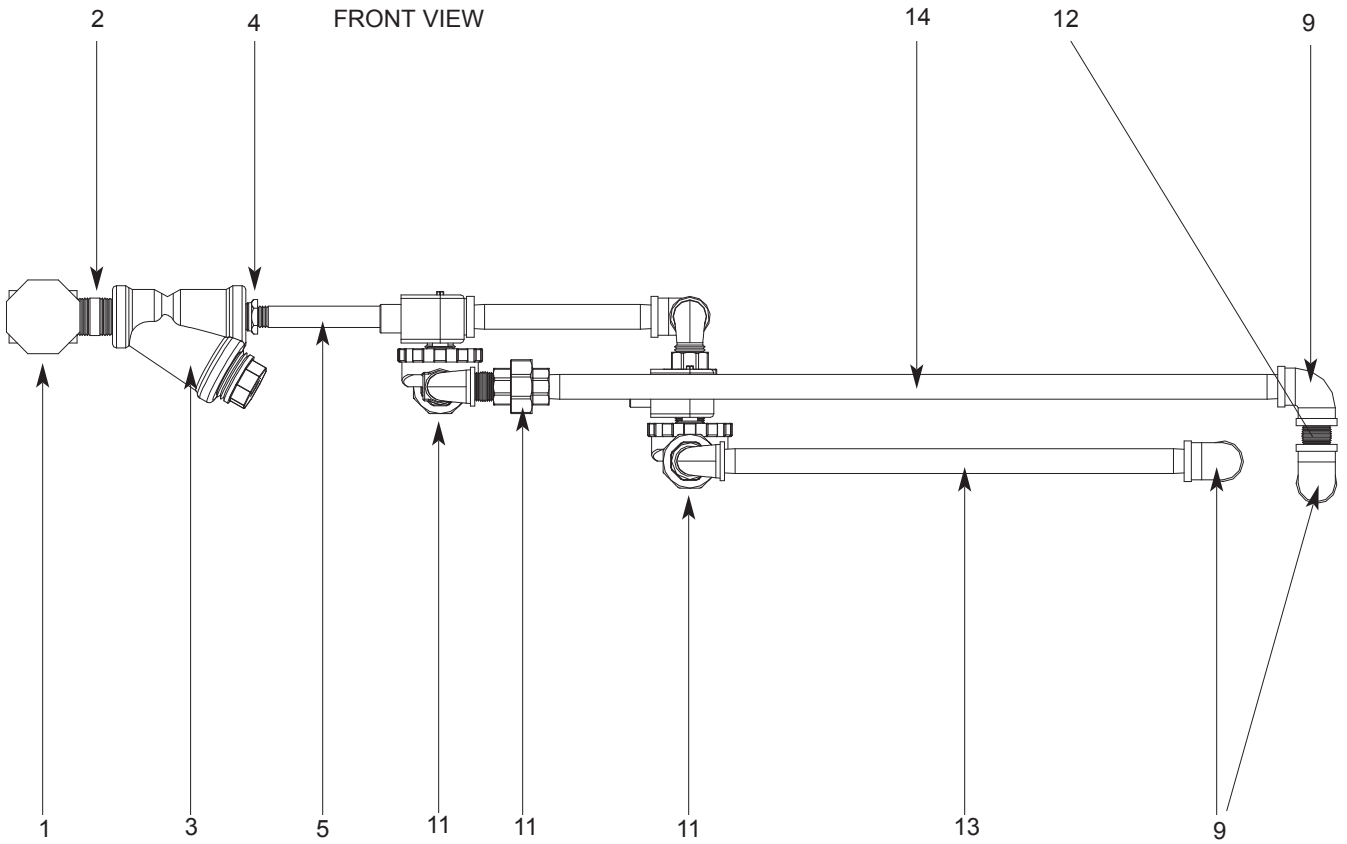
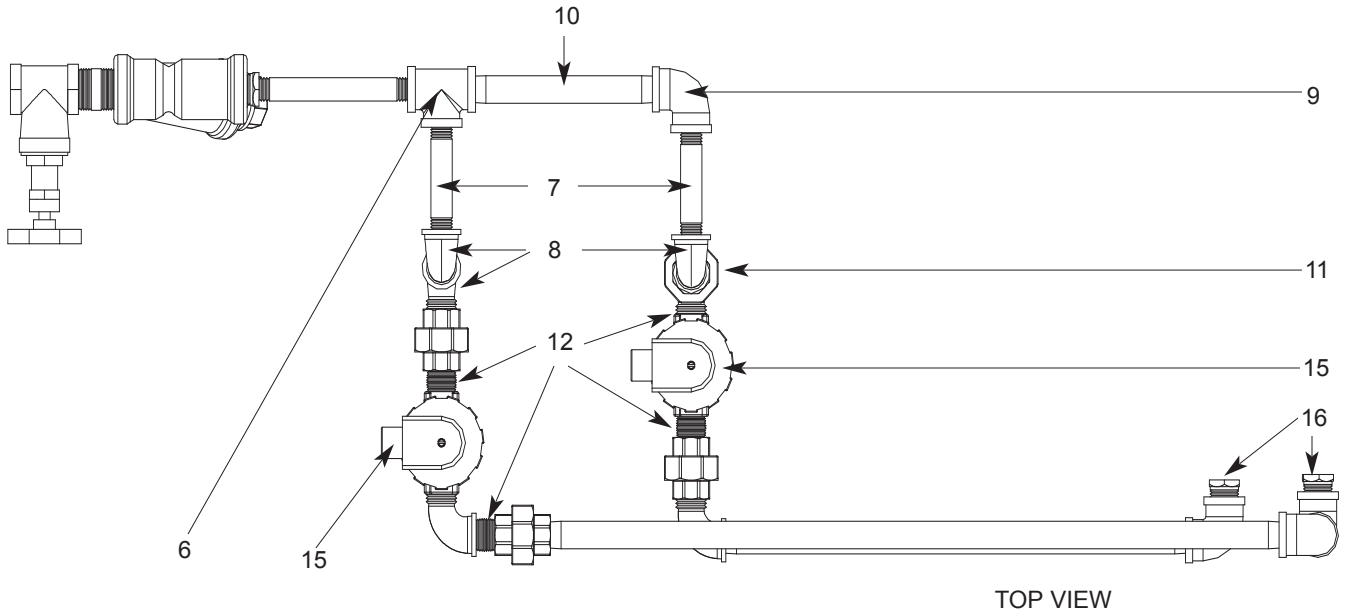

SECTION 5: PARTS SECTION

STEAM INLET PLUMBING ASSEMBLY (RIGHT TO LEFT MODELS)(CONTINUED)

ITEM	QTY	DESCRIPTION	Mfg. No.
1	1	Valve, 1" Gate	04820-011-87-30
2	1	Nipple, 1" NPT, Close, Black Iron	04730-907-08-34
3	1	Y-Strainer, 1" NPT, Black Iron	04730-217-02-32
4	1	Reducer, 1" NPT to 3/4" NPT	04730-011-95-66
5	1	Nipple, 3/4" NPT x 6" Long, Black Iron	04730-907-01-34
6	1	Tee, 3/4" x 3/4" x 3/4", Black Iron	04730-002-74-14
7	2	Nipple, 3/4" NPT x 4" Long, Black Iron	04730-907-02-34
8	6	Elbow, Street, 3/4" NPT, 90°, Black Iron	04730-011-87-37
9	4	Elbow, 3/4" NPT, 90°, Black Iron	04730-906-10-34
10	1	Nipple, 3/4" NPT x 7" Long, Black Iron	05700-002-74-15
11	4	Union, 3/4" NPT, Black Iron	04730-912-01-00
12	5	Nipple, 3/4" NPT, Close, Black Iron	04730-907-01-00
13	1	Nipple, 3/4" NPT x 17" Long, Black Iron	05700-002-74-16
14	1	Nipple, 3/4" NPT x 26-1/2" Long, Black Iron	05700-002-74-17
15	2	Valve, Solenoid, Steam, 3/4" NPT, 120V	04820-011-87-39
16	2	Reducer, 3/4" NPT to 1/2" NPT	04730-911-02-34

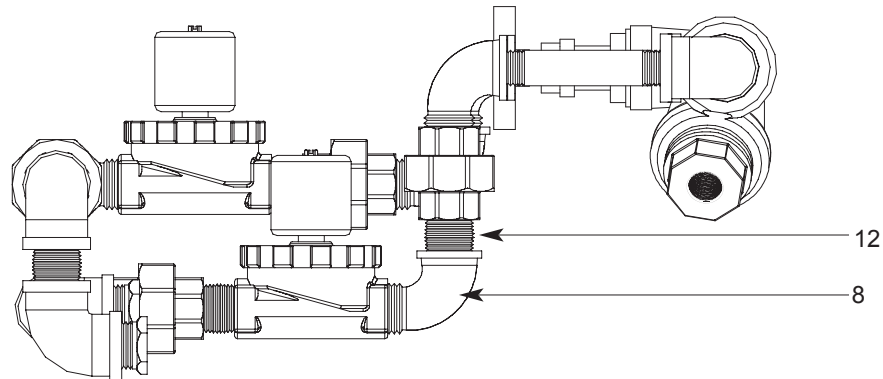

RIGHT SIDE VIEW

SECTION 5: PARTS SECTION
STEAM OUTLET PLUMBING (LEFT TO RIGHT)

TOP PLUMBING
05700-002-81-66

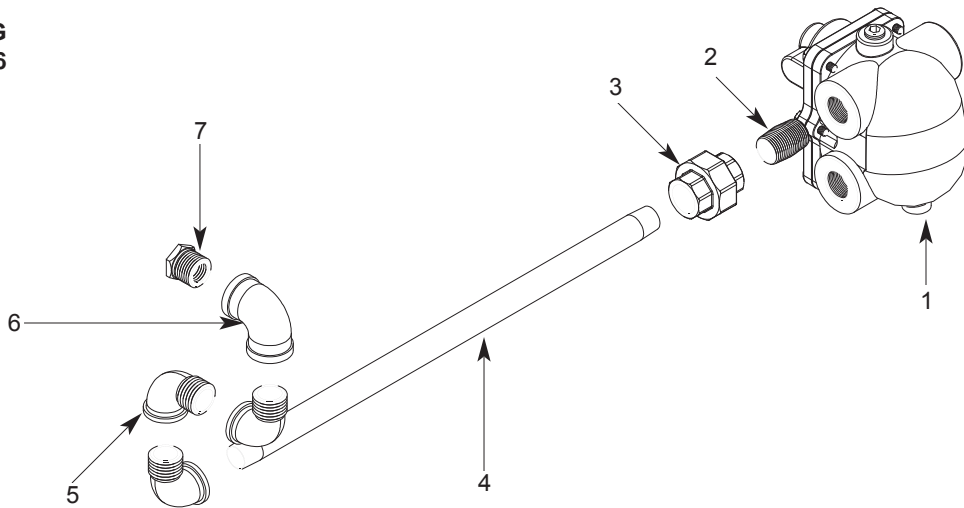

ITEM	QTY	DESCRIPTION	Mfg. No.
1	-	Trap, Steam, 3/4" NPT	06680-500-02-77
2	-	Nipple, Close, 3/4" NPT, Black Iron	04730-907-01-00
3	-	Union, 3/4" NPT, Black Iron	04730-912-01-00
4	-	Nipple, 3/4" x 18" Long, Black Iron	05700-002-74-10
5	-	Elbow, 90° Street, 3/4" NPT, Black Iron	04730-011-87-37
6	-	Elbow, 90°, 3/4" NPT, Black Iron	04730-906-10-34
7	-	Reducer, 3/4" NPT to 1/2" NPT Black Iron	04730-911-02-34
8	-	Nipple, 3/4" NPT x 26-1/2" Long, Black Iron	04730-911-02-34

BOTTOM PLUMBING
05700-002-81-65

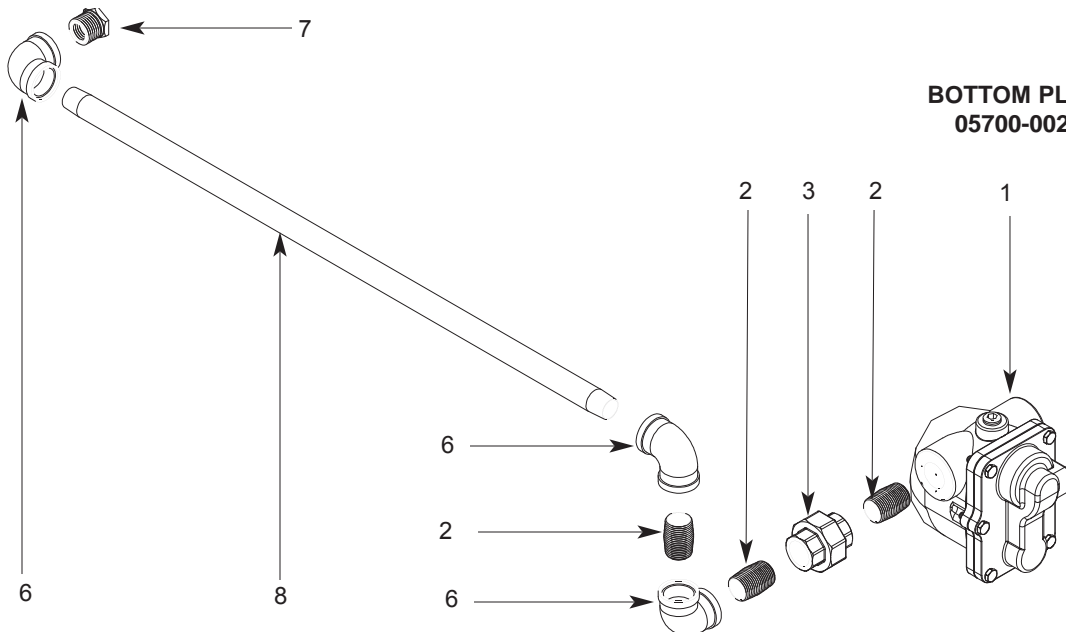

SECTION 5: PARTS SECTION
STEAM OUTLET PLUMBING (RIGHT TO LEFT)

TOP PLUMBING

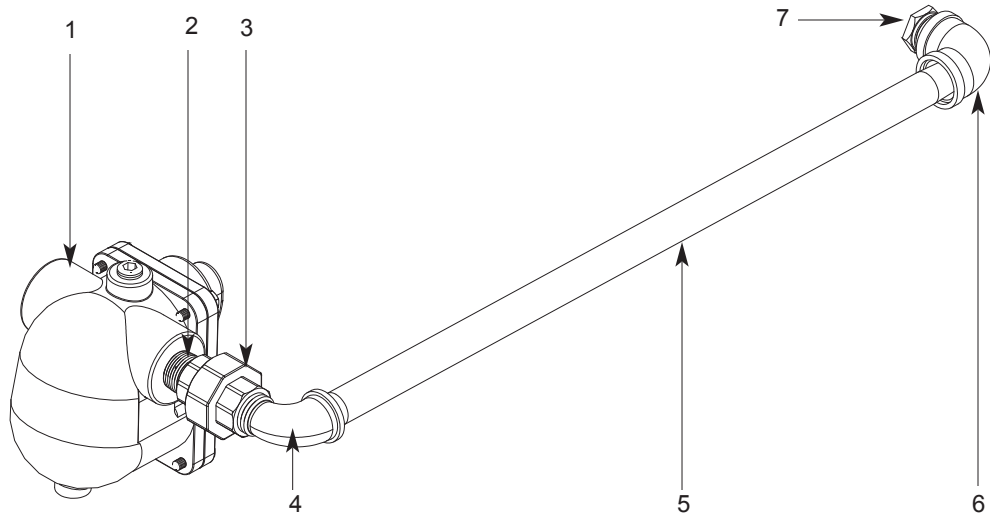

ITEM	QTY	DESCRIPTION	Mfg. No.
1	-	Steam Trap	06680-500-02-77
2	-	Nipple, Close, 3/4", Black Iron	04730-907-01-00
3	-	Union, 3/4" NPT, Black Iron	04730-912-01-00
4	-	Elbow, Street, 90°, Black Iron	04730-011-87-37
5	-	Nipple, 3/4" NPT x 22" Long, Black Iron	05700-002-74-08
6	-	Elbow, 90°, 3/4" FNPT, Black Iron	04730-906-10-34
7	-	Reducer, 3/4" NPT x 1/2" NPT	04730-911-02-34
8	-	Nipple, 3/4" NPT x 18" Long, Black Iron	05700-002-74-10

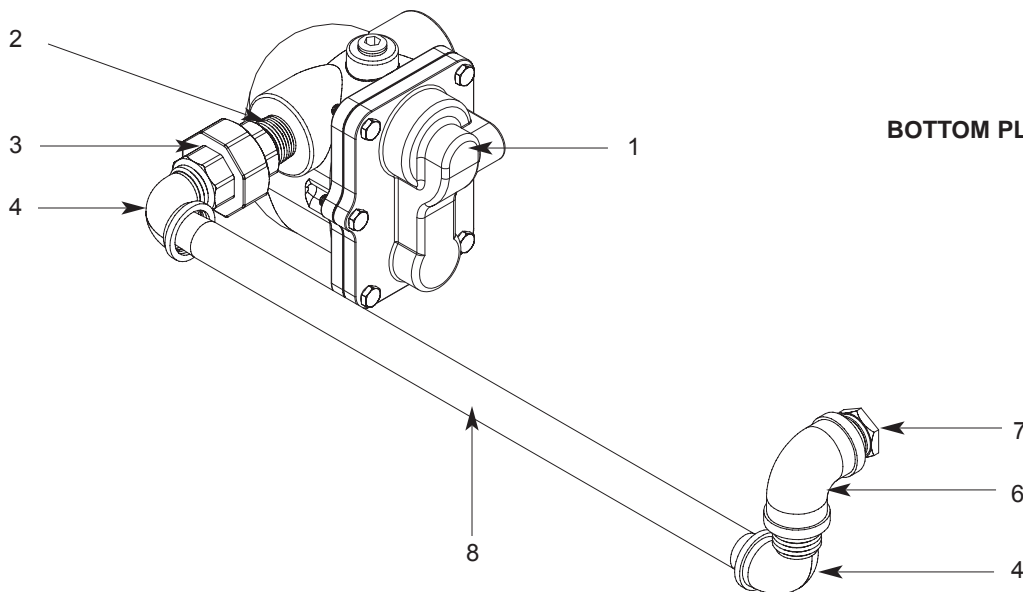

BOTTOM PLUMBING

SECTION 5: PARTS SECTION
AJ-86 GAS COIL ASSEMBLY (CGP MODELS)

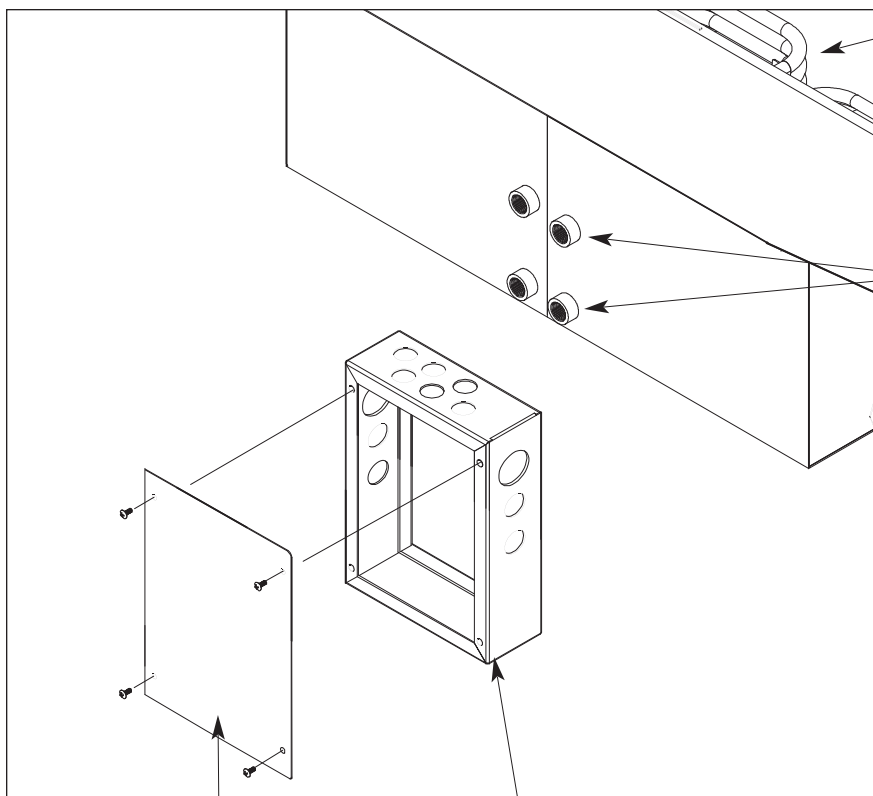

(See "Wash Tank Coil Assembly" page)

(See "Hose Connections" page)

Connects with:
 3/4" 90° Elbow Brass
 04730-206-13-00

3/4" Close Brass Nipple
 04730-207-34-00

Gas Coil Box Cover
 05700-002-48-50

Coil Box Weldment
 05700-002-50-94

Other items used but not shown.

ITEM	QTY	DESCRIPTION	Mfg. No.
1	1	Thermostat, High Limit	05930-011-49-43
2	1	Gasket	05330-200-02-70
3	1	Terminal Board	05940-002-78-97
4	1	Thermostat Bracket	05700-011-81-64
5	1	Decal, Thermostat Regulating	09905-011-84-31
6	1	Thermostat, Wash Regulating	06401-140-00-32
7	1	Fitting, 1/4", Imperial Brass	05310-924-02-05

SECTION 5: PARTS SECTION
TANK, RINSE BOOSTER (CGP MODELS ONLY)

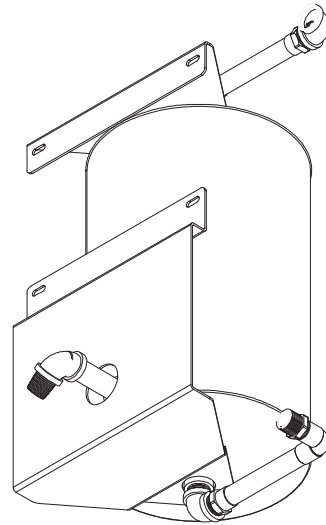
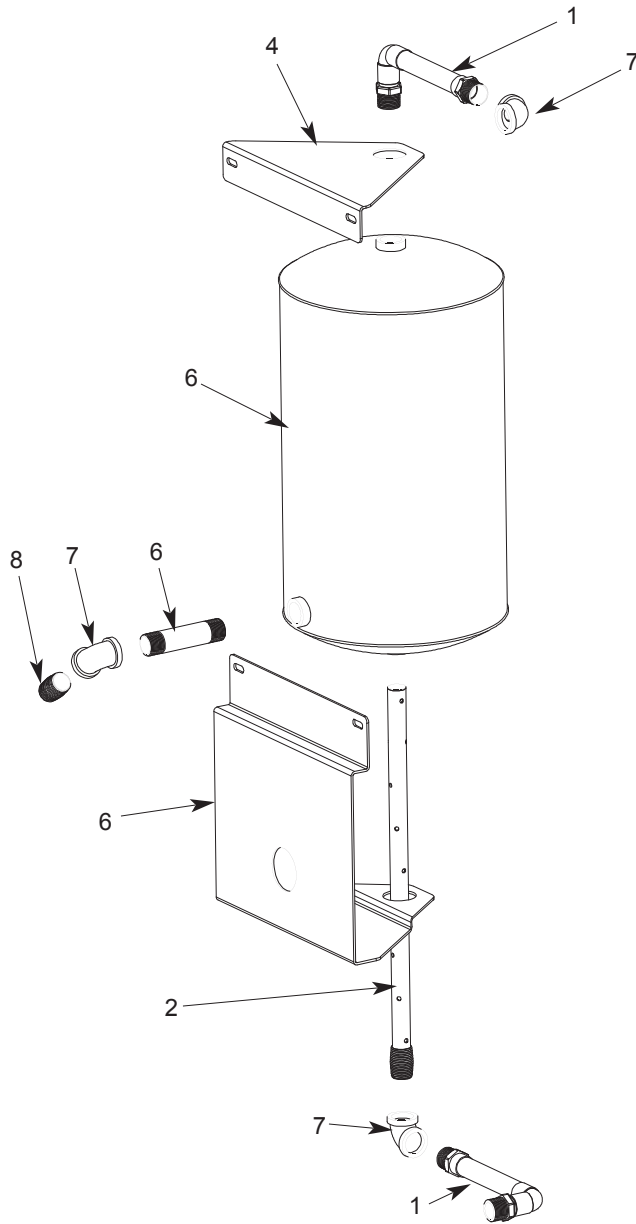

BOTTOM ANGLED VIEW

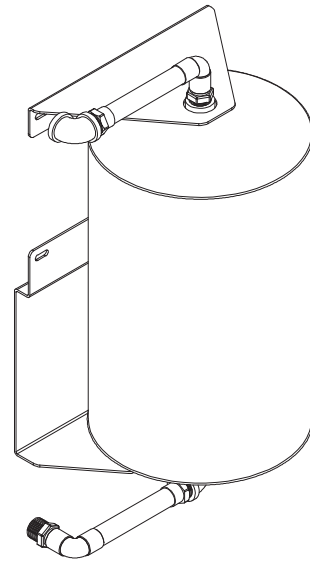

TOP ANGLED VIEW

ITEM	QTY	DESCRIPTION	Mfg. No.
1	2	Plumbing Assembly, Inlet/Discharge, Rinse Tank	05700-002-51-24
2	1	Tube, Dispersion Weldment	05700-002-46-16
3	1	Tank, GP Rinse	05700-002-45-05
4	1	Bracket, Upper Rinse Tank	05700-002-67-13
5	1	Bracket, Lower Rinse Tank	05700-002-67-14
6	1	Nipple, 3/4" NPT x 4" Long	04730-207-05-00
7	3	Elbow, 3/4" NPT, 90° Brass	04730-206-13-00
8	1	Nipple, 3/4" NPT x Closed Brass	04730-207-34-00

SECTION 5: PARTS SECTION
RECIRCULATING PUMP ASSEMBLY (CGP MODELS ONLY)

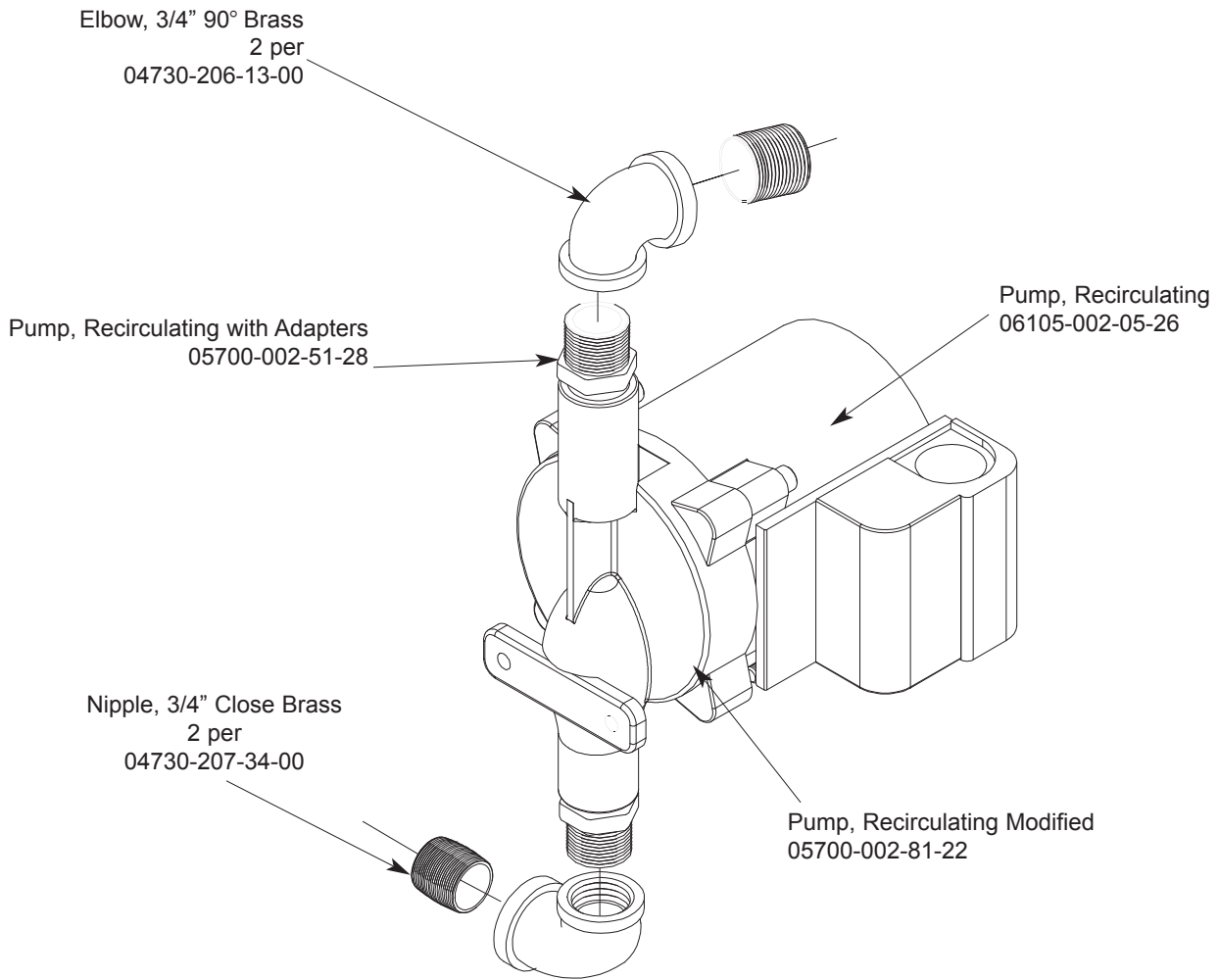

Used only on AJ-86CGP left to right units.

Used on AJ-64CGP, AJ-86CGP, AJ-100CGP units right to left units and the AJ-64CGP left to right unit.

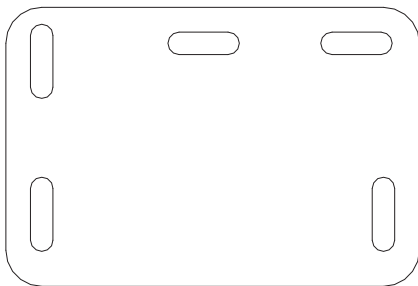

Mounting Bracket
05700-002-25-74

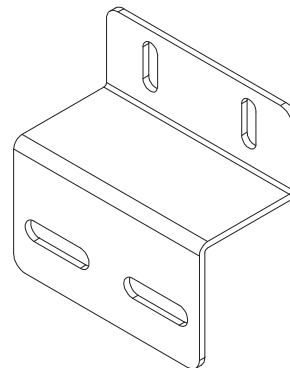

Mounting Bracket
05700-002-23-61

SECTION 5: PARTS SECTION
HOSE CONNECTIONS (CGP MODELS ONLY)

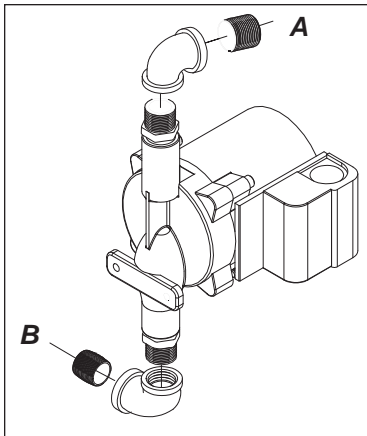

Recirculating Pump Assembly

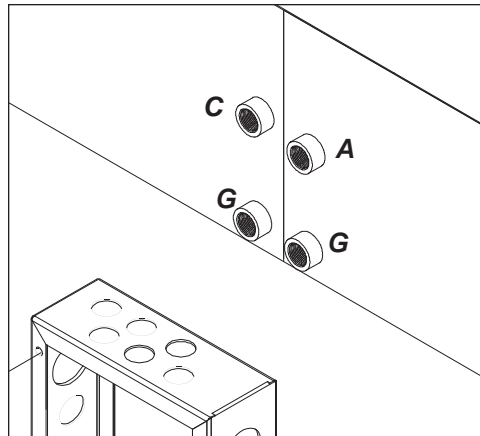

Gas Coil Weldment

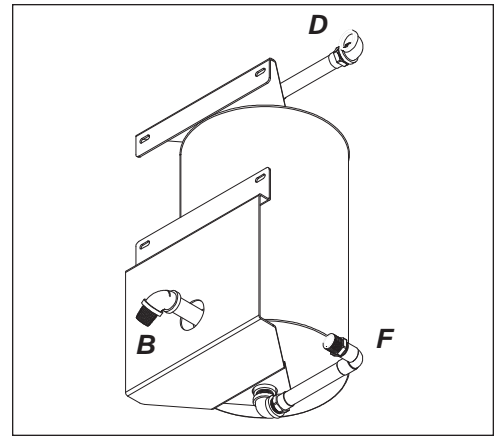

Rinse Booster Tank

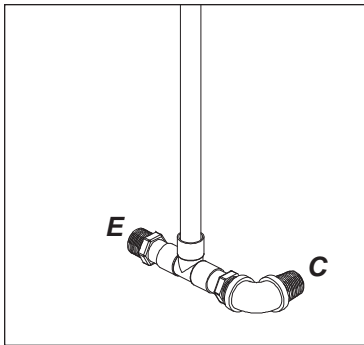

Rinse Header Plumbing Assembly

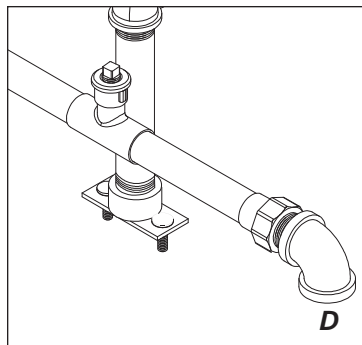

Wash/Fill Plumbing Assembly

HOSE ASSEMBLIES

AJ-86CGP (L-R & R-L)

AJ-100CGP (L-R)

*Each hose assembly includes 2, 3/4" Pushlock Fittings part number 04730-011-94-00.

A - Hose, Recirculating Discharge	05700-002-52-74	05700-002-52-76
B - Hose, Recirculating Pump Suction	05700-002-52-75	05700-002-51-38
C - Hose, Wash Coil Assembly	05700-002-52-76	04720-011-94-10 (66")
D - Hose, Wash/Fill Supply	05700-003-03-97	05700-003-03-99
E - Hose connection to existing gas booster outlet fitting.		
F - Hose connection to existing gas booster inlet fitting.		
G - Hose, Coil Recirculating	05700-002-17-71	05700-002-17-71

Gas Booster Connection Kit 05700-002-51-73 includes:
 18 Feet of 3/4" Hose
 4 - 3/4" Push Lock Fittings

SECTION 5: PARTS SECTION

AJ-64 DRAIN PLUMBING ASSEMBLY

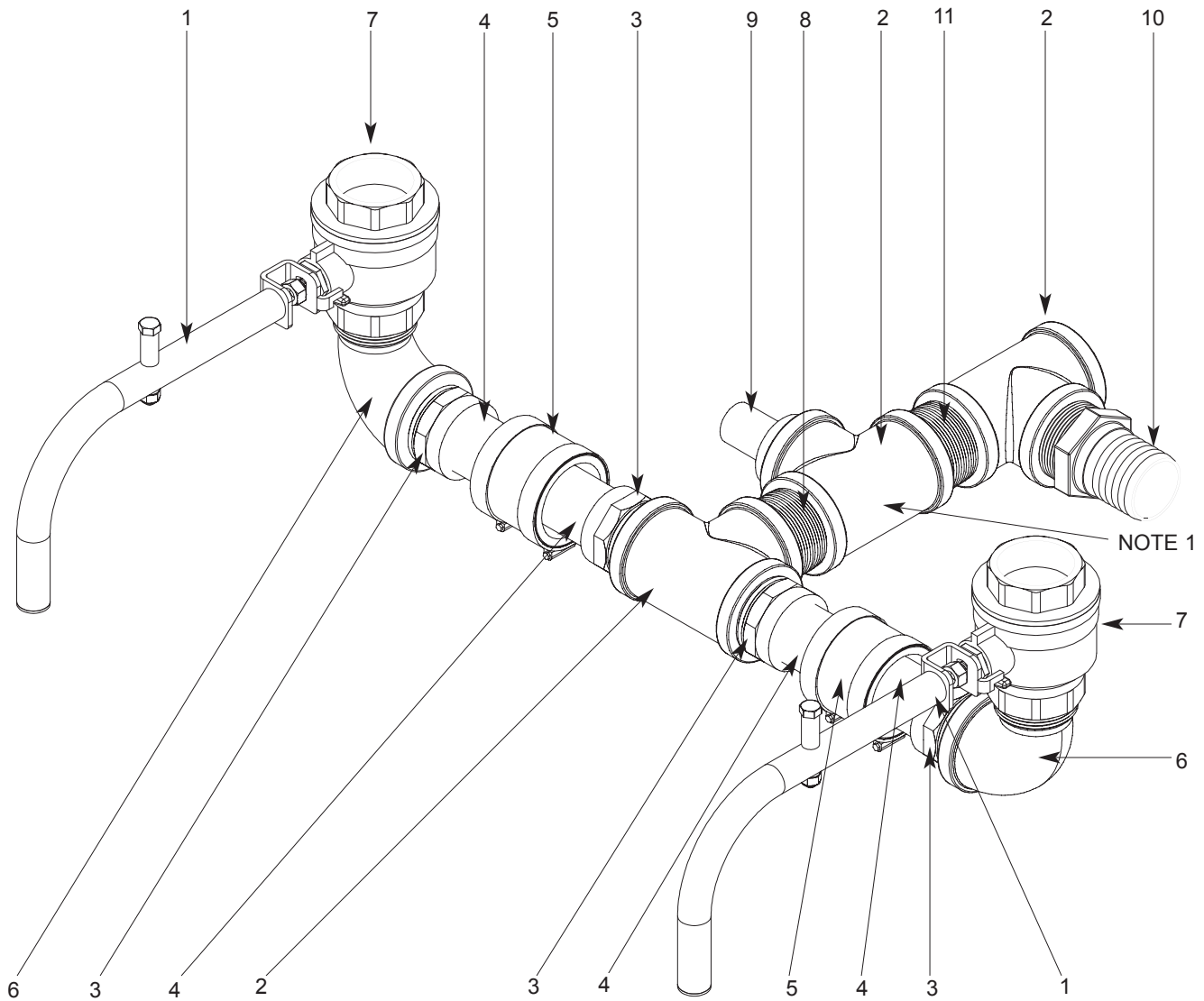

ITEM	QTY	DESCRIPTION	Mfg. No.
1	2	Ball Valve Handle Assembly	05700-021-84-74
	1	Spacer (Not Shown)	05700-002-87-05
2	3	Tee, Brass, 1-1/2" x 1-1/2" x 1-1/2"	04730-011-69-93
3	4	Adapter, 1-1/2"	04730-401-25-01
4	4	Tube, Copper, 1-1/2" OD x 2" Long	05700-011-87-16
5	2	Connector, No-Hub, 1-1/2"	04720-604-06-00
6	2	Elbow, 1-1/2", Street, Brass, 90°	04730-206-32-00
7	2	Valve, Ball, 1-1/2" NPT	04820-111-71-46
8	1	Nipple, 1-1/2" NPT, Brass, Close	04730-207-40-00
9	1	Rinse Nipple Weldment	05700-021-84-61
10	1	Fitting, Barbed, 1-1/2" NPT x 1-1/2"	04730-011-69-92
11	1	Nipple, Brass, 1-1/2" x 3" Long	04730-011-87-04

NOTE 1: Component is shown for installation in a Right-to-Left model; component is rotated 180 degrees for Left-to-Right units.

SECTION 5: PARTS SECTION

AJ-86 & AJ-100 DRAIN PLUMBING ASSEMBLY (LEFT TO RIGHT MODELS)

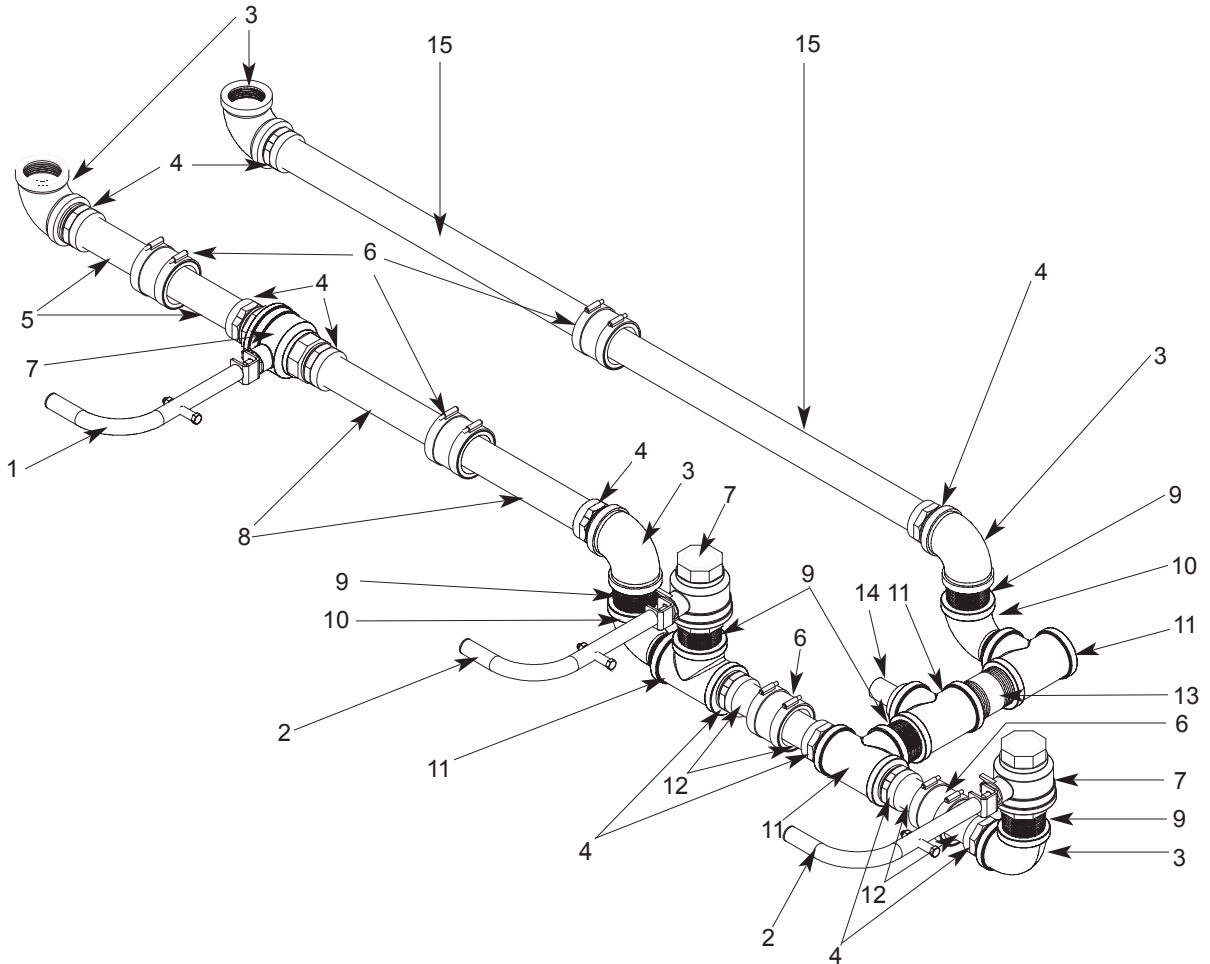

ITEM	QTY	DESCRIPTION	Mfg. No.
1	1	Ball Valve Handle Spacer (Not Shown)	05700-021-84-74 05700-002-87-05
2	2	Ball Valve Handle Spacer (Not Shown)	05700-021-83-53 05700-002-87-05
3	5	Elbow, 1-1/2" FNPT, 90° Brass	04730-011-73-77
4	10	Adapter, 1-1/2"	04730-401-25-01
5	2	Tube, Copper, 1-1/2" OD x 4-7/16" Long (AJ-86 Models)	05700-011-84-22
	2	Tube, Copper, 1-1/2" OD x 5-1/4" Long (AJ-100 Models)	05700-002-79-12
6	5	Connector, No-Hub, 1-1/2"	04720-604-06-00
7	3	Ball Valve, 1-1/2"	04820-011-71-46
8	2	Tube, Copper, 1-1/2" OD x 7-3/4" Long (AJ-86 Models)	05700-021-84-24
	2	Tube, Copper, 1-1/2" OD x 13-3/4" Long (AJ-100 Models)	05700-021-88-17
9	5	Nipple, 1-1/2" NPT, Brass, Close	04730-207-40-00
10	2	Elbow, 1-1/2" NPT, Brass, Street	04730-206-32-00
11	4	Tee, Brass, 1-1/2" NPT	04730-011-69-93
12	4	Tube, Copper, 1-1/2" OD x 2" Long	05700-011-87-16
13	1	Nipple, Brass, 1-1/2" NPT x 3" Long	04730-011-87-04
14	1	Rinse Nipple Weldment	05700-021-84-61
15	2	Tube, Copper, 1-1/2" OD x 20-1/8" Long (AJ-86 Models)	05700-021-84-29
	2	Tube, Copper, 1-1/2" OD x 27-1/2" Long (AJ-100 Models)	05700-021-84-28

SECTION 5: PARTS SECTION

AJ-86 & AJ-100 DRAIN PLUMBING ASSEMBLY (RIGHT TO LEFT MODELS)

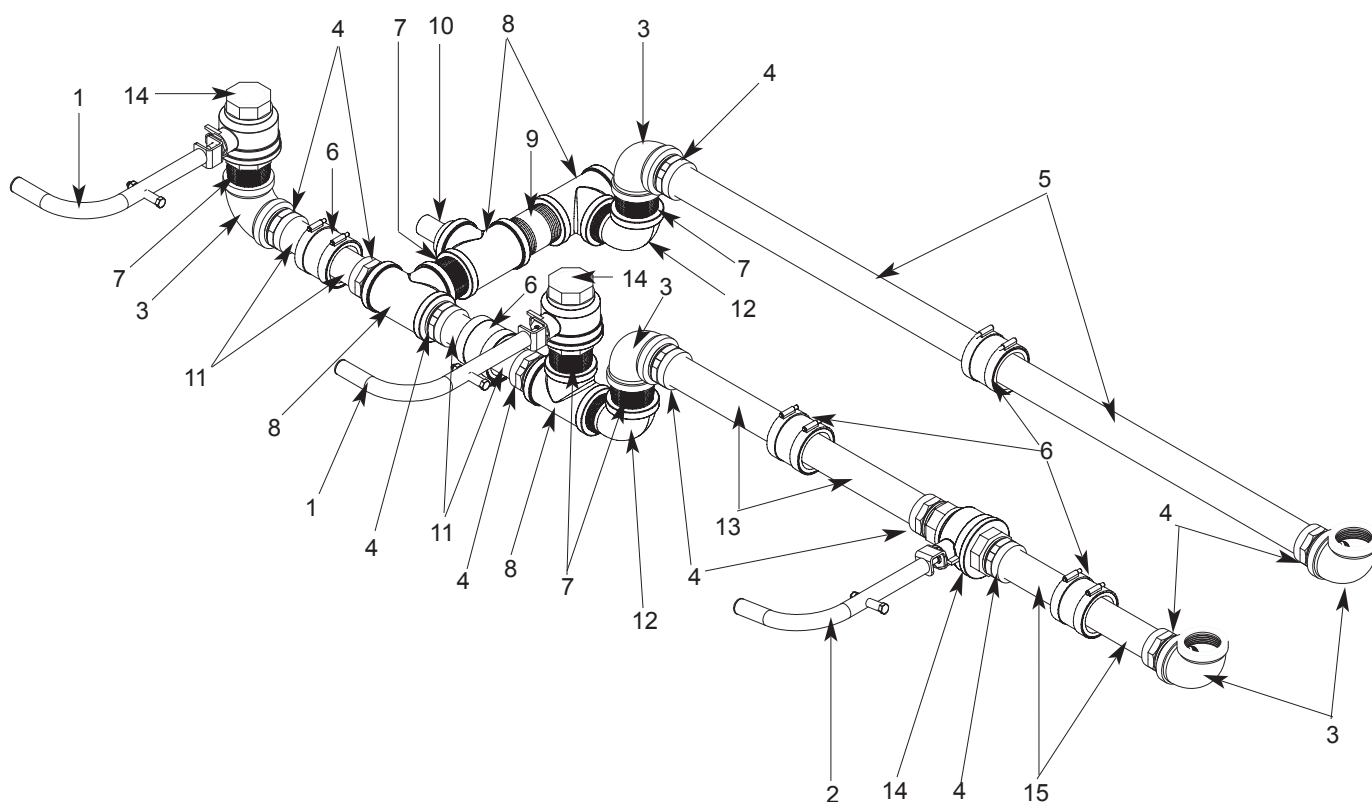

ITEM	QTY	DESCRIPTION	Mfg. No.
1	2	Ball Valve Handle Assembly Spacer (Not Shown)	05700-021-83-53
2	1	Ball Valve Handle Assembly Spacer (Not Shown)	05700-002-87-05 05700-021-84-74 05700-002-87-05
3	5	Elbow, 1-1/2" FNPT, 90°, Brass	04730-011-73-77
4	10	Adapter, 1-1/2" NPT	04730-401-25-01
5	2	Tube, 1-1/2" x 20-1/8" Long (AJ-86 Models)	05700-021-84-29
	2	Tube, Copper, 1-1/2" x 27-1/2" Long (AJ-100 Models)	05700-021-84-28
6	5	Connector, No Hub, 1-1/2"	04720-604-06-00
7	5	Nipple, 1-1/2" NPT, Brass, Close	04730-207-40-00
8	4	Tee, 1-1/2" NPT x 1-1/2" NPT x 1-1/2" NPT	04730-011-69-93
9	1	Nipple, 1-1/2" NPT x 3 Long, Brass	04730-011-87-04
10	1	Rinse Nipple Weldment	05700-021-84-61
11	4	Tube, Copper, 1-1/2" x 2" Long	05700-011-87-16
12	2	Elbow, 1-1/2" NPT, 90°, Brass, Street	04730-206-32-00
13	2	Tube, Copper, 1-1/2" x 7-3/4" Long (AJ-86 Models)	05700-021-84-24
	2	Tube, Copper, 1-1/2" x 13-3/4" Long (AJ-100 Models)	05700-021-88-17
14	3	Valve, Ball, 1-1/2" NPT	04820-011-71-46
15	2	Tube, Copper, 1-1/2" x 4-7/16" Long (AJ-86 Models)	05700-011-84-22
	2	Tube, Copper, 1-1/2" x 5-1/4" Long (AJ-100 Models)	05700-002-79-12

SECTION 5: PARTS SECTION

DRAIN VALVE HANDLE ASSEMBLY/DRAIN QUENCH SYSTEM

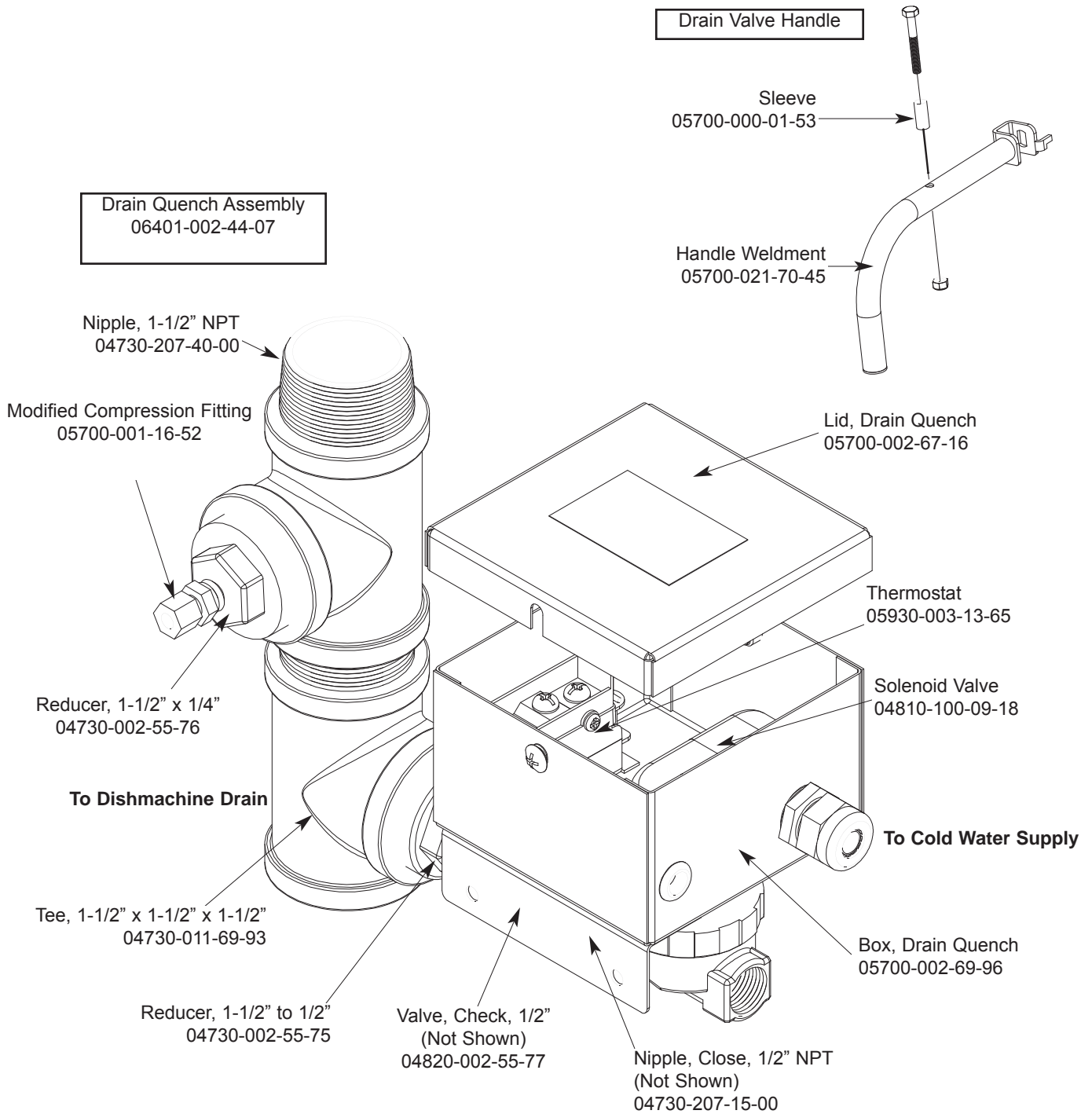

From the existing drain, attach the two additional Tees using the 1-1/2" NPT Close Nipples. Tighten the Reducers into the Tees as shown above. Attach the Modified Compression Fitting into the 1-1/2" to 1/4" Reducer. Position the bulb of the thermostat so that it rests approximately 1/4" from the bottom of the Tee. Tighten the Modified Compression Fitting as required. Attach to the incoming cold water line. Use pipe dope or thread tape as required to prevent any leaks.

SECTION 5: PARTS SECTION

MOTOR ASSEMBLIES

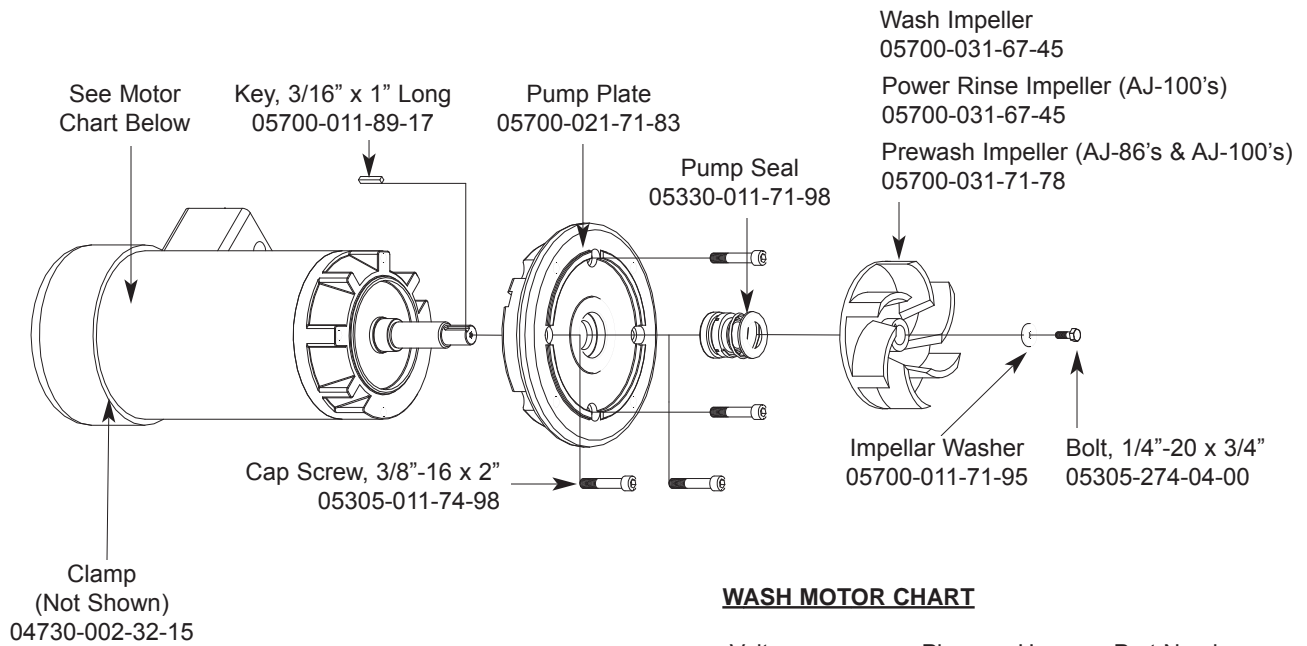

WASH MOTOR CHART

Volts	Phase	Hz	Part Number
208 - 230	1	60	06105-021-70-57
200 - 230	3	60	06105-121-70-58
460	3	60	06105-121-70-58

PREWASH MOTOR CHART

Model(s)	Volts	Phase	Hz	Part Number
AJ-86's	208	1	60	06105-121-70-55
	230	1	60	06105-121-70-55
	208	3	60	06105-121-70-56
	230	3	60	06105-121-70-56
	460	3	60	06105-121-70-56
AJ-100's	208	1	60	06105-121-70-57
	230	1	60	06105-121-70-57
	208	3	60	06105-121-70-58
	230	3	60	06105-121-70-58
	460	3	60	06105-121-70-58

POWER RINSE MOTOR CHART

Model(s)	Volts	Phase	Hz	Part Number
AJ-100's	208	1	60	06105-121-70-57
	230	1	60	06105-121-70-57
	208	3	60	06105-121-70-58
	230	3	60	06105-121-70-58
	460	3	60	06105-121-70-58

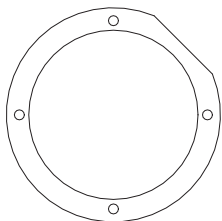
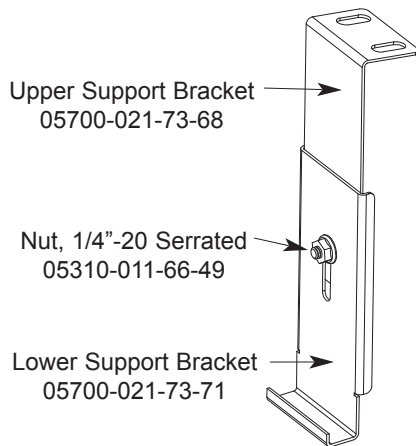

Motor Mounting Gasket
05330-011-71-62

SECTION 5: PARTS SECTION
PREWASH & WASH PUMP WELDMENT

Prewash Strainer Bracket
05700-021-74-94

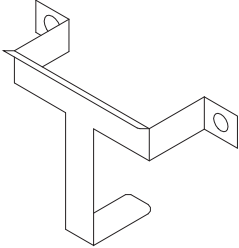

Prewash Intake Strainer Weldment
05700-021-74-96

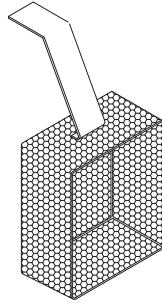

Intake Suction Scoop Weldment
05700-021-87-60

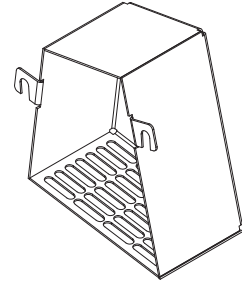

The pump weldment is secured to the pump plate (through the actual tub wall) using the following fasteners:

- | | |
|-------------------------|-----------------|
| Nut, Hex, 3/8"-16 | 05310-276-01-00 |
| Washer, Flat, 3/8" | 05311-176-01-00 |
| Lockwasher, Split, 3/8" | 05311-276-01-00 |

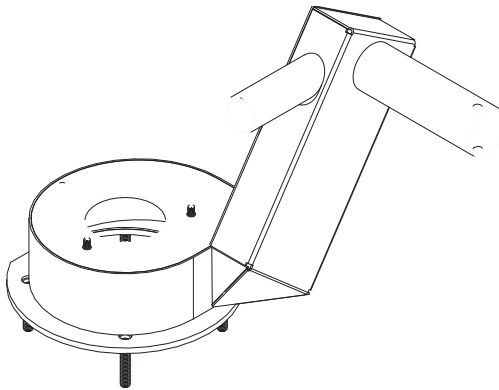

The power rinse pump weldment is a single part. Separate pieces of the weldment are not available for purchase.

Power Rinse Pump Weldment (AJ-100's)
05700-031-81-47

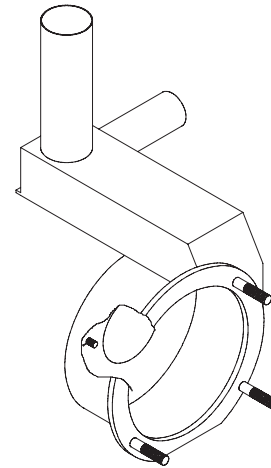

The wash pump weldment is a single part. Separate pieces of the weldment are not available for purchase. The weldment is used for the wash pump in all models covered in this manual. The weldment may be ordered using part number 05700-041-68-88.

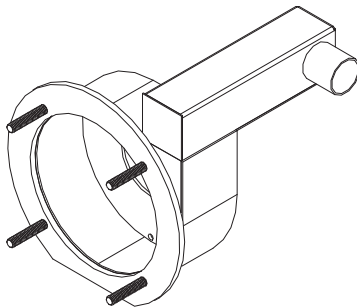

The prewash pump weldment is a single part. Separate pieces of the weldment are not available for purchase.

Prewash Pump Weldment
AJ-86/AJ-100 Left to Right models: 05700-002-10-62

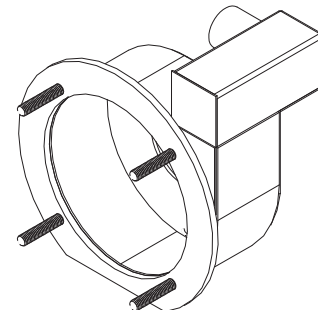

The prewash pump weldment is a single part. Separate pieces of the weldment are not available for purchase.

Prewash Pump Weldment
AJ-86/AJ-100 Right to Left models: 05700-002-11-96

SECTION 5: PARTS SECTION
PREWASH & UPPER WASH ARM ASSEMBLIES



Upper Wash Manifold Support Bracket
05700-021-73-97

Replacement Kit Note:
 The replacement kit for the end cap includes the endcap, lanyard, mounting screw and the locknut.

End Cap Replacement Kit
06401-003-10-19

Prewash Tube Weldment
05700-001-16-89

Complete Prewash Arm Assembly
05700-021-74-65

Upper Wash Arm Weldment
05700-031-67-34

Complete Upper Wash Arm Assembly
05700-031-74-99

Replacement Kit Note:
 The replacement kit for the end cap includes the endcap, lanyard, mounting screw and the locknut.

End Cap Replacement Kit
06401-003-10-19

End Cap
05700-011-67-11

Cap, Wash Tube
05700-021-69-68

Lanyard
05340-011-72-46

Locknut, 10-24 with Nylon Insert
05310-373-01-00

Screw, 10-32 x 3/8" Truss Head
05305-173-12-00

SERVICE NOTE: When replacing the 10-32 screws in the End Caps, it is recommended that a thread locking fluid be used to ensure that the screws do not back out during normal operation.

SECTION 5: PARTS SECTION

LOWER WASH ARM ASSEMBLY

Lower Wash Arm Support Bracket
05700-011-71-20
Secured with Locknut, 1/4"-20 with Nylon Insert
05310-374-01-00

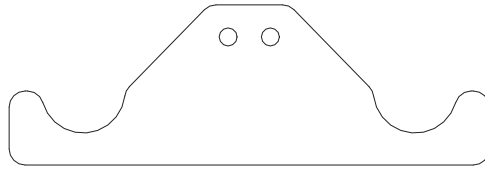

Screw, 10-32 x 3/8" Truss Head
05305-173-12-00

End Cap
6 per
05700-011-67-11

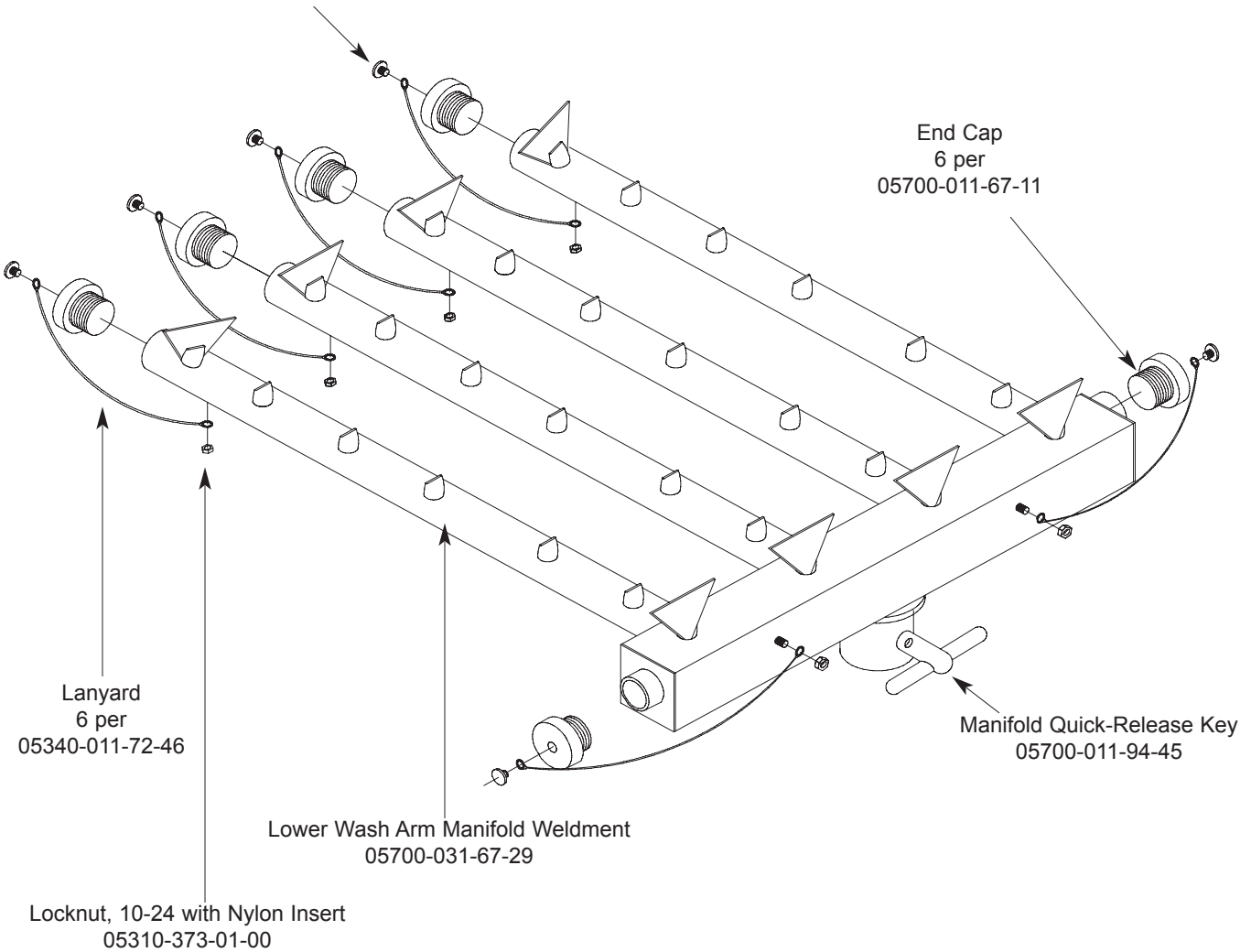

Lanyard
6 per
05340-011-72-46

Lower Wash Arm Manifold Weldment
05700-031-67-29

Manifold Quick-Release Key
05700-011-94-45

Locknut, 10-24 with Nylon Insert
05310-373-01-00

**Complete Lower Wash Arm Assembly
05700-031-74-66**

SERVICE NOTE: When replacing the 10-32 screws in the End Caps, it is recommended that a thread locking fluid be used to ensure that the screws do not back out during normal operation.

SECTION 5: PARTS SECTION

UPPER & LOWER POWER RINSE ARM ASSEMBLIES

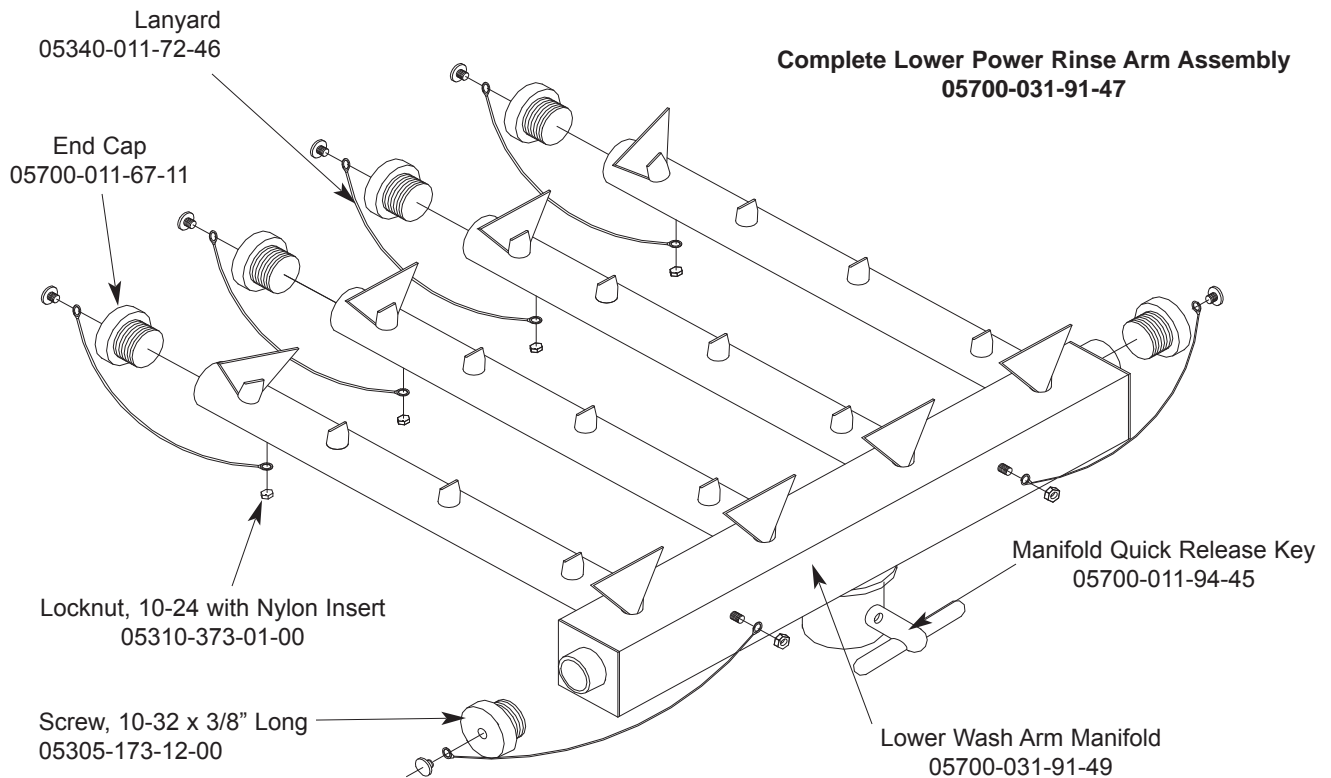
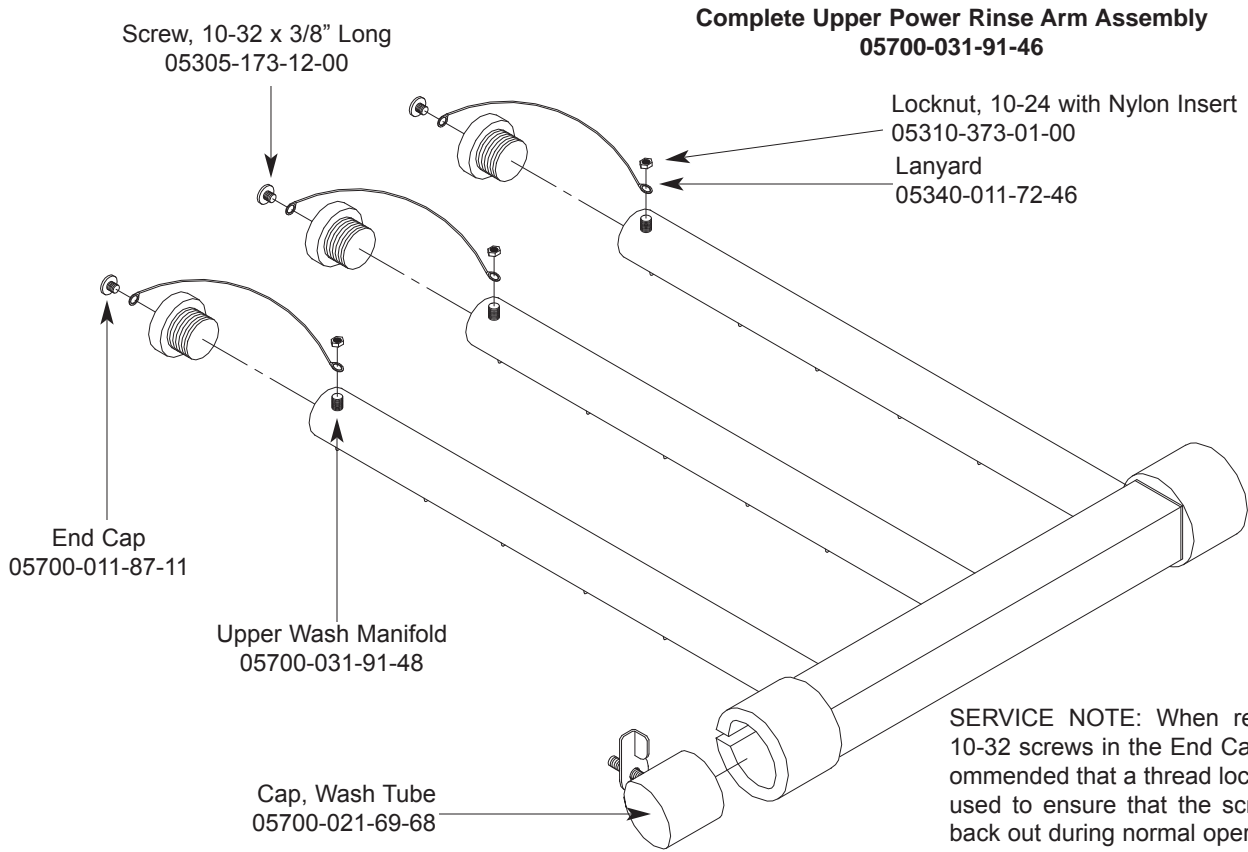

SECTION 5: PARTS SECTION

FINAL RINSE ASSEMBLY

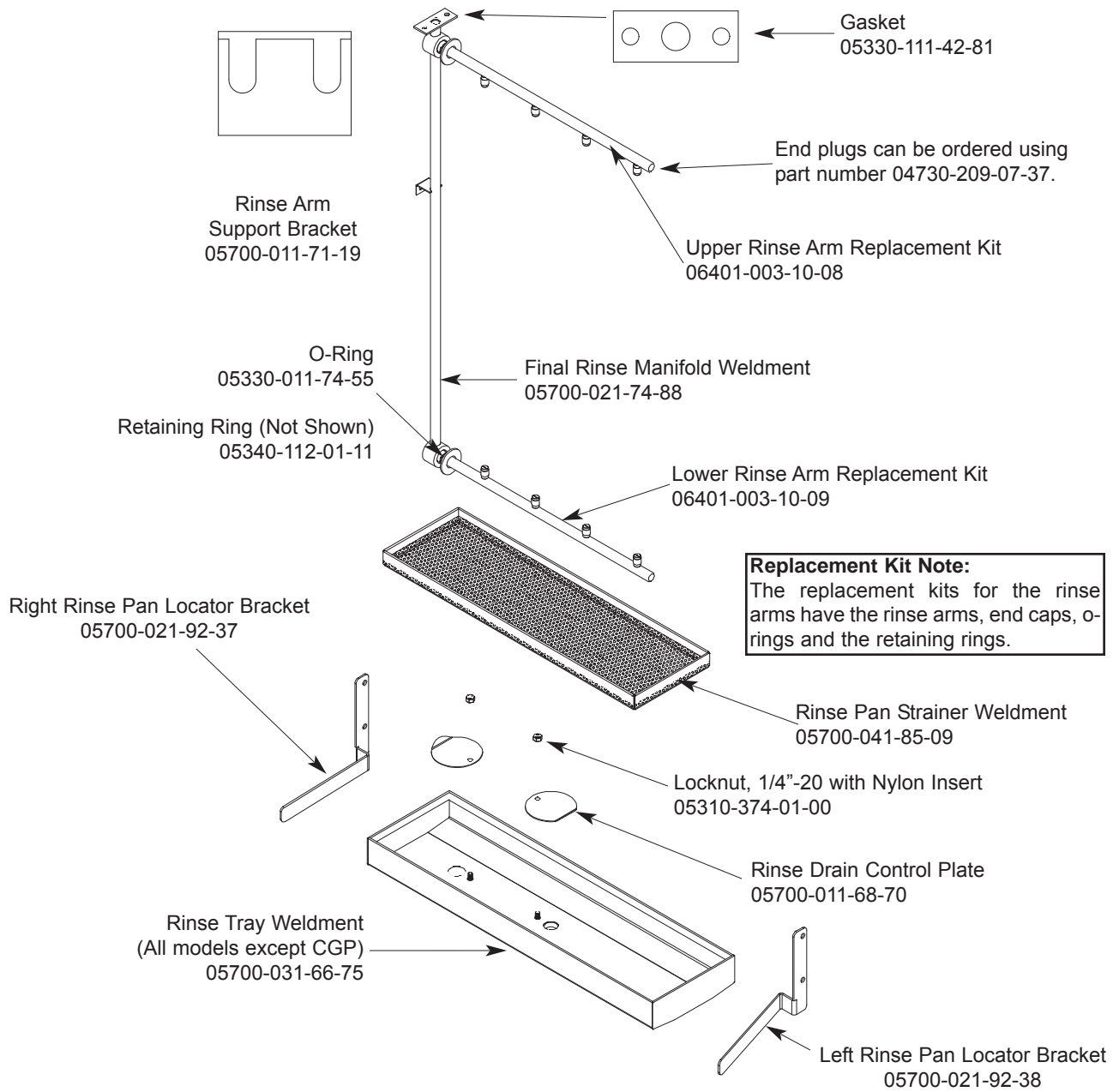

Optional Parts for CGP Models

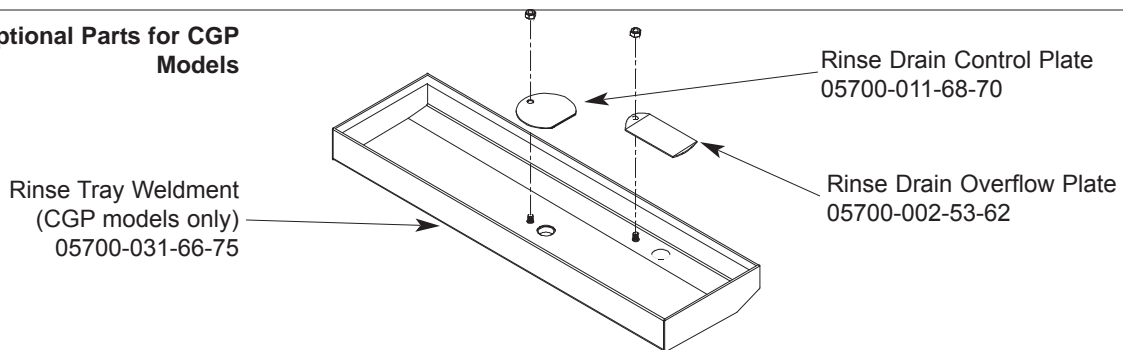

SECTION 5: PARTS SECTION
DRIVE ASSEMBLY

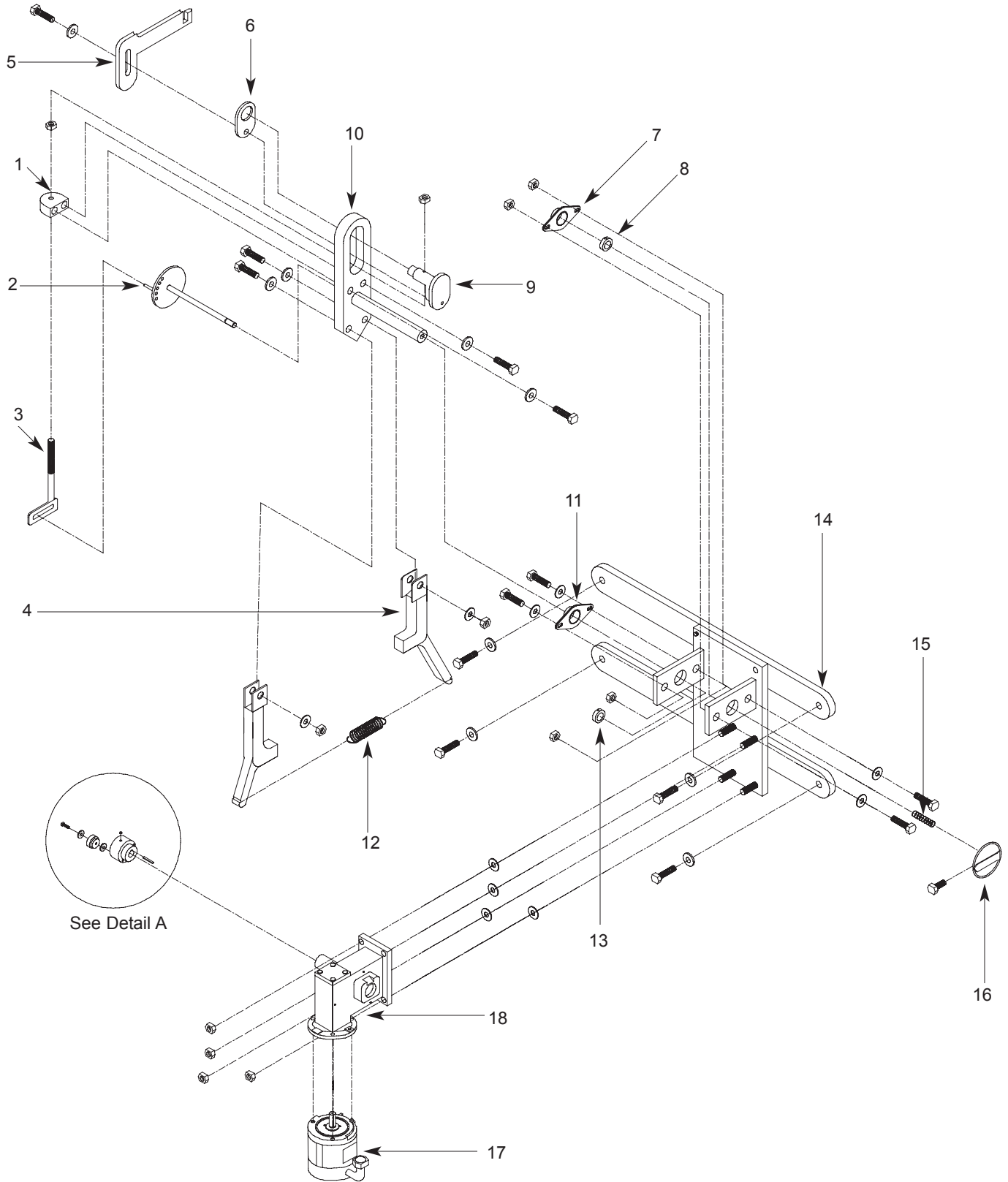

SECTION 5: PARTS SECTION

DRIVE ASSEMBLY (CONTINUED)

ITEM	QTY	DESCRIPTION	Mfg. No.
1	1	Drive Plate and Rod Weldment	05700-021-67-44
		Replacement Kit with Expansion Legs	06401-021-86-80
		Replacement Kit with Expansion Legs/Adjuster Crank	06401-011-94-54
2	1	Adjuster Crank Assembly	05700-021-69-95
3	1	Scotch Yoke Weldment Replacement Kit	06401-003-08-48
4	2	Coupling & Expansion Leg Weldment	09515-003-58-12
5	1	Pawl Bar Drive Linkage Casting	09515-021-87-73
6	1	Spacer Plate	05700-011-67-58
7	2	Pillow Block Replacment Kit	06401-003-08-50
8	2	Shaft Collar	05700-011-89-18
9	1	Drive Socket	05700-021-67-39
10	1	Drive Plate	05700-021-67-42
11	2	Pillow Block	03120-021-71-87
12	1	Drive Spring	05315-011-83-51
13	2	Shaft Collar	05700-011-89-18
14	1	Drive Motor Mounting Bracket	05700-031-73-56
15	1	Adjuster Spring	05315-011-71-90
16	1	Adjusting Handle Weldment	05700-021-72-28
17	1	Drive Motor Replacement Kits	
	1	Drive Motor (208-230 Volt, 60 Hz, Single Phase Models)	06401-003-08-42
	1	Drive Motor (208-230 Volt, 60 Hz, Three Phase Models)	06401-003-08-40
18	1	Gear Drive	06105-011-71-88
19	1	Roller Bearing	03120-011-71-81
20	1	Drive Hub	05700-011-67-97

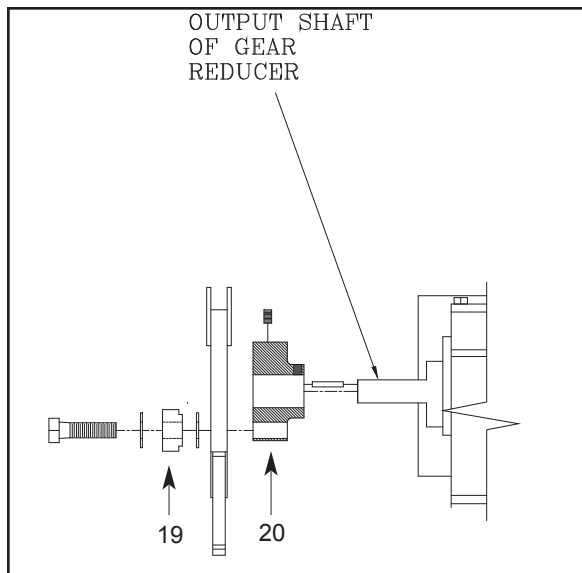

Detail A

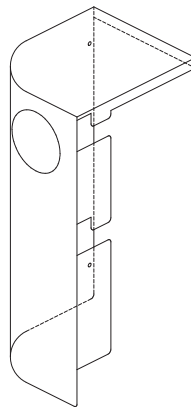

Front Drive Motor Cover
Replacement Kit
06401-003-11-64

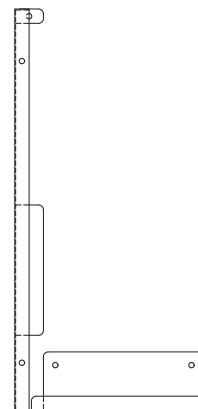

Rear Drive Motor Cover
Replacment Kit
06401-003-10-18

Replacement Kits Notes:

The replacement kits for the drive motor covers come with the weldments and the mounting hardware.

SECTION 5: PARTS SECTION

DOOR ASSEMBLIES

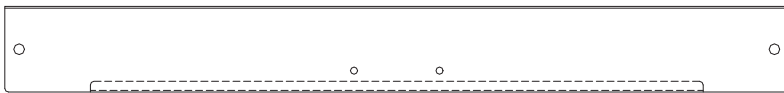
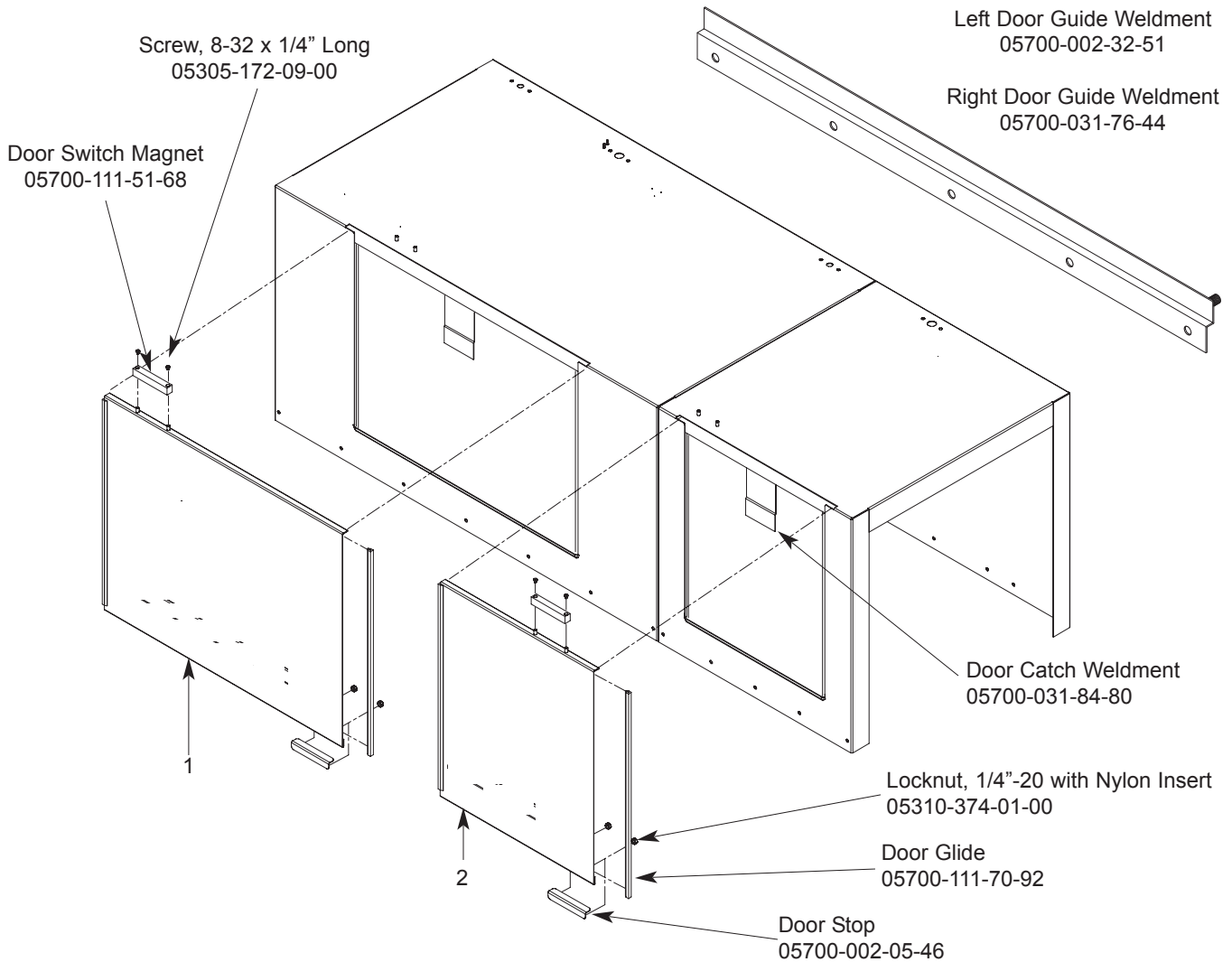

Wash Door Hood Support: 05700-031-84-13
 Prewash Door Hood Support: 05700-031-84-14

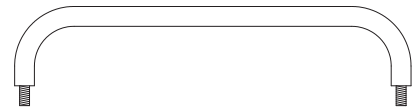

Wash Door Handle Weldment
 05700-011-82-63

Prewash Door Handle Weldment
 05700-011-80-45

ITEM	QTY	DESCRIPTION	Mfg. No.
1	1	Wash Door Weldment	05700-031-83-39
1	1	Wash Door Weldment (No Emboss)	05700-003-13-53
2	1	Prewash Door Weldment (Left to Right Model)	05700-031-95-05
2	1	Prewash Door Weldment (Right to Left Model)	05700-031-95-07
2	1	Prewash Door Weldment - No Emboss (Left to Right Model)	05700-003-13-42
2	1	Prewash Door Weldment - No Emboss (Right to Left Model)	05700-003-13-40
		Wash Door Stiffener (Not Shown)	05700-031-83-43
		Prewash Door Stiffener (Not Shown)	05700-031-83-57

SECTION 5: PARTS SECTION
PAWL BAR MISCELLANEOUS COMPONENTS

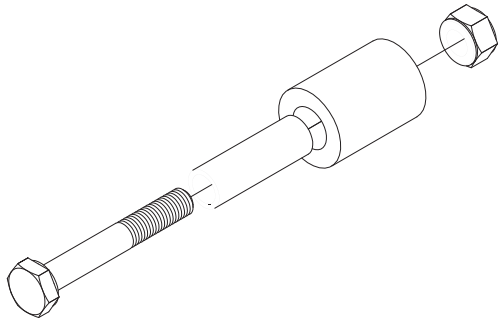

Pawl Bar Roller Replacement Kit
 06401-003-11-80

Replacement Kit Notes:
 The replacement kit for the pawl bar roller comes with the roller, roller shaft, hardware and locknut as shown.

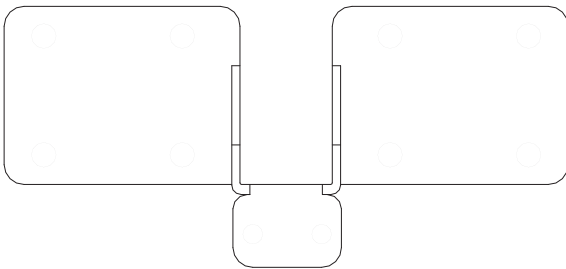

Pawl Bar Bracket (without tabs) Weldment
 05700-031-92-36

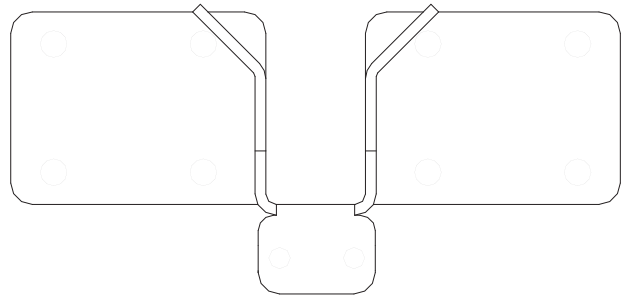

Pawl Bar Bracket (with studs) Weldment
 05700-031-84-68

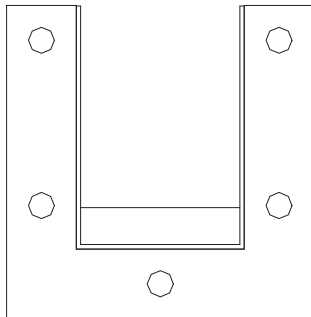

Pawl Bar Gutter Weldment Replacement Kit
 06401-003-09-95

Replacement Kits Notes:
 The pawl bar gutter weldment replacement kit contains the weldment, a gasket and the mounting hardware. The guide block kit contains both blocks and a gasket.

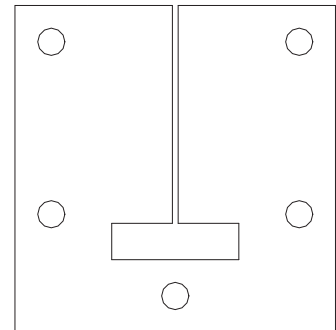

Pawl Bar Gutter Gasket
 05330-011-68-55

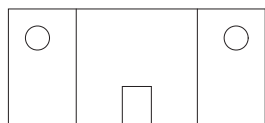

Top Guide Block

Guide Block Replacement Kit
 06401-003-10-15

Bottom Guide Block

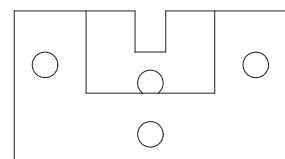

Service Note: It is highly recommended that when changing out one guide block, that the other be changed out as well, along with the gasket.

SECTION 5: PARTS SECTION

PAWL BAR ASSEMBLIES

PAWL BAR ASSEMBLY, LEFT TO RIGHT OPERATION

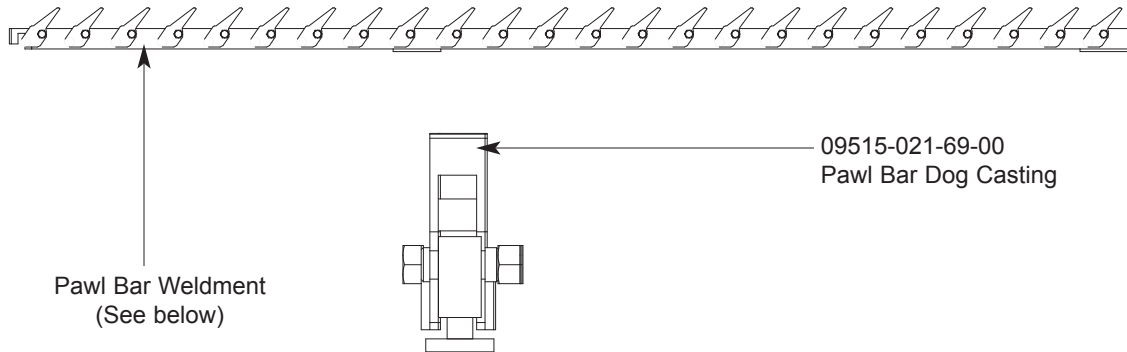

PAWL BAR ASSEMBLY, RIGHT TO LEFT OPERATION

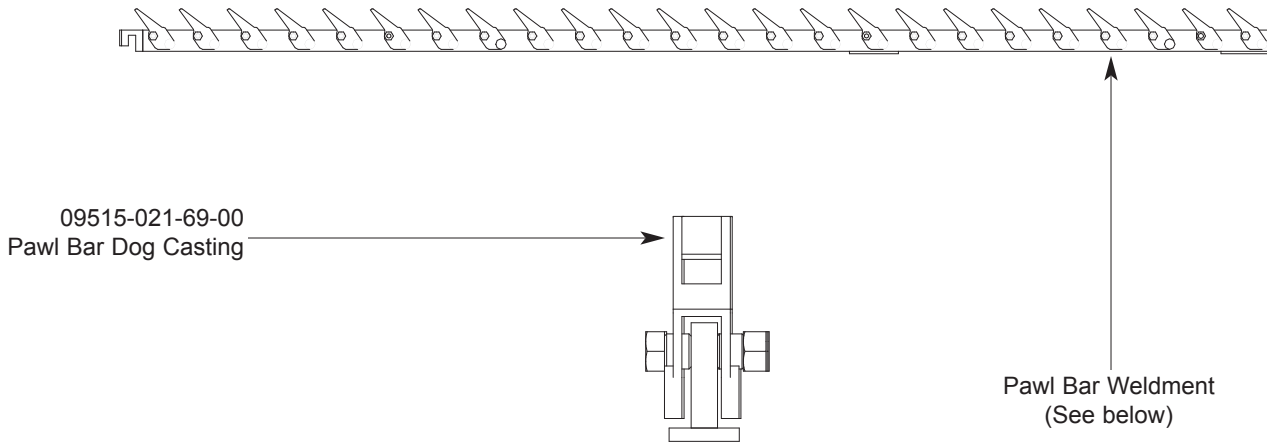

PAWL BAR ASSEMBLIES:

Model	Left to Right Pawl Bar Weldment	Right to Left Pawl Bar Weldment	Pawl Bar Dogs	Complete Assembly	Prison Package
AJ-64	05700-031-81-03	05700-031-81-03	18	06401-131-81-02	06401-231-81-02
AJ-86	05700-041-83-67	05700-002-81-34	24	06401-131-83-75 (L-R) 06401-231-83-75 (R-L)	06401-331-83-75
AJ-86 With Side Loader	N/A	05700-003-13-63	24	N/A (L-R) 05700-003-13-64 (R-L)	N/A N/A
AJ-100	05700-041-91-13	05700-041-91-13	28	06401-141-91-05	06401-241-91-05

PAWL BAR WELDMENT AJ-86 RIGHT TO LEFT WITH A SIDE LOADER



SECTION 5: PARTS SECTION

RACK RAIL ASSEMBLIES

Left to Right Assembly (AJ-86
Model shown for reference)

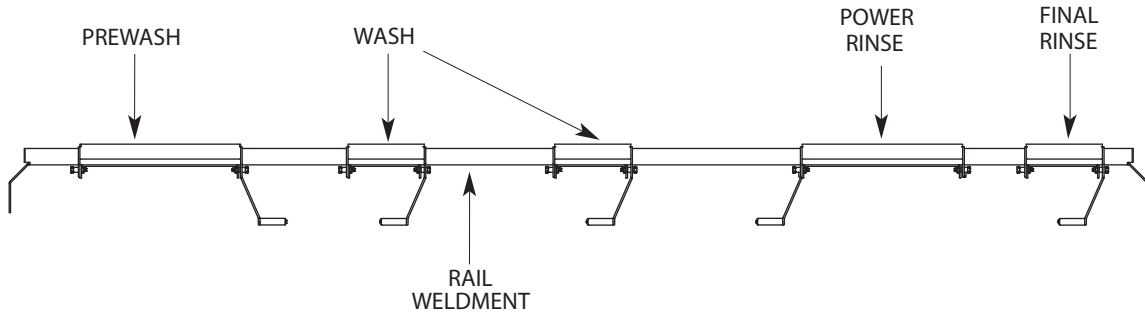

Right to Left Assembly (AJ-86
Model shown for reference)

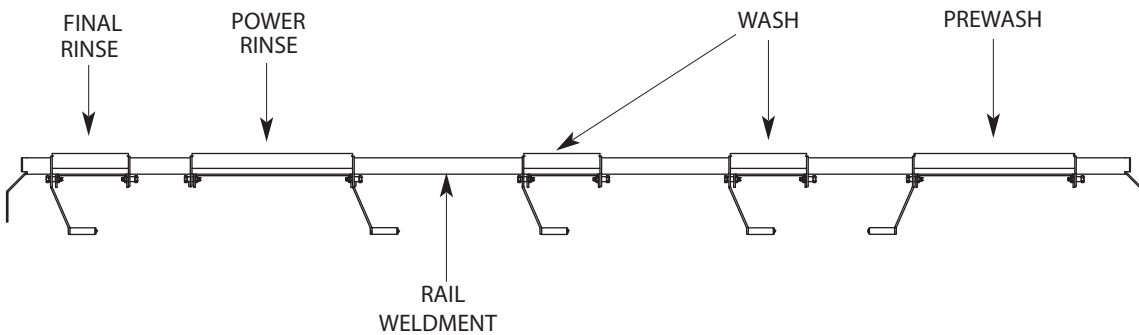

LEFT TO RIGHT:

<u>COMPONENT</u>	<u>AJ-64 MODELS</u>	<u>AJ-86 MODELS</u>	<u>AJ-100 MODELS</u>
Prewash Actuator	Not Applicable	05700-021-76-97	05700-021-75-68
Wash Actuator	05700-021-72-39	05700-021-72-39	05700-021-72-39
Power Rinse Actuator	05700-002-91-09	05700-002-91-09	05700-002-91-09
Final Rinse Actuator	05700-021-72-39	05700-021-72-39	05700-021-72-39
Rail Weldment	05700-002-74-57	05700-031-83-96	05700-041-94-91
Complete Assembly	05700-002-74-55	05700-041-83-72	05700-041-94-90

RIGHT TO LEFT:

<u>COMPONENT</u>	<u>AJ-64 MODELS</u>	<u>AJ-86 MODELS</u>	<u>AJ-100 MODELS</u>
Prewash Actuator	Not Applicable	05700-021-76-97	05700-021-76-96
Wash Actuator	05700-021-72-39	05700-021-72-39	05700-002-91-10
Power Rinse Actuator	05700-021-72-39	05700-022-91-09	05700-021-72-39
Final Rinse Actuator	05700-021-72-39	05700-021-72-39	05700-021-72-39
Rail Weldment	05700-002-74-58	05700-041-91-21	05700-041-91-03
Complete Assembly	05700-002-74-56	05700-041-91-20	05700-041-91-04

SECTION 5: PARTS SECTION
MISCELLANEOUS PARTS AND WELDMENTS

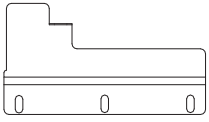

Plate, Left Water Directional
 05700-021-79-27

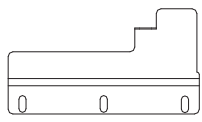

Plate, Right Water Directional
 05700-021-79-23

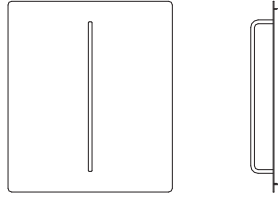

Run Off Sheet Weldment
 05700-021-71-39

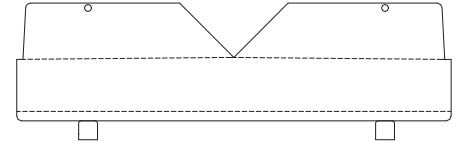

Splash Shield Weldment
 05700-031-85-16

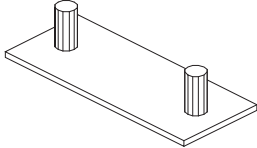

Hole Direction Plate Replacement Kit
 06401-003-10-00

Replacement Kit Note:
 The kit for the hole direction plate comes with the plate, a new gasket and the mounting hardware.

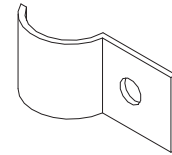

Pipe Clamp
 05700-000-35-05

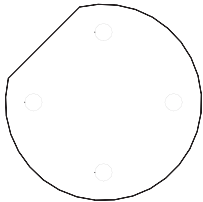

Rinse Drain Plate Replacement Kit
 (CGP Models Only)
 06401-003-10-07

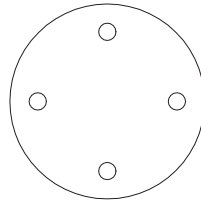

Rinse Drain Plug Replacement Kit
 06401-003-10-06

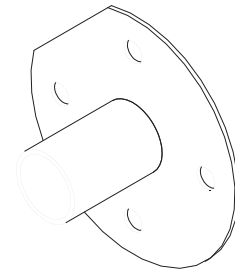

Rinse Drain Weldment Replacement Kit
 06401-003-10-05

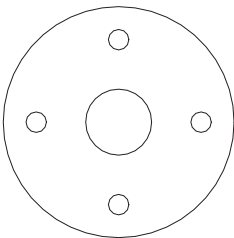

Rinse Drain Plate Gasket
 05330-011-72-27

Replacement Kits Notes:
 The kits for the drain weldments and drain plugs come with the weldments/parts, a new gasket and the mounting hardware.

SECTION 5: PARTS SECTION
MANIFOLDS/STRAINER SUPPORT WELDMENTS

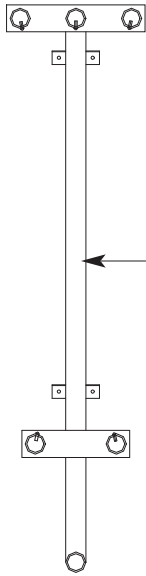

Prewash Manifold Weldment
 AJ-86 Models Only
 05700-031-69-70
 Prewash Manifold Weldment
 AJ-100 Models Only
 05700-002-24-94

Secured to the Hood Weldment with:

Washer, Flat, S/S, 1/4" ID
 05311-174-01-00

Locknut, 1/4"-20 with Nylon Insert
 05310-374-01-00

Wash Manifold Weldment
 05700-031-71-13

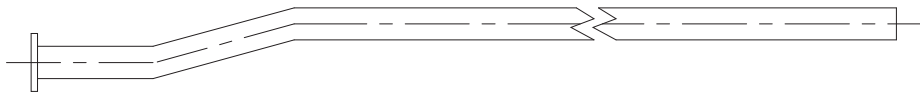
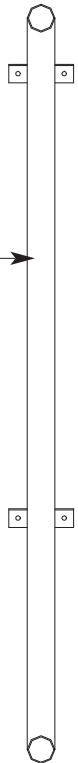

Wash Fill Tube Weldment
 05700-021-71-21

Vellumoid Gasket
 05330-111-42-81

Prewash Fill Tube Weldment
 (AJ-86 & AJ-100 Models Only)
 05700-021-74-76

Secured with Locknut, 1/4"-20 with Nylon Insert
 05310-374-01-00

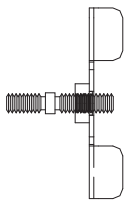

Shoulder Bolt Wingnut Weldment
 05700-002-46-02

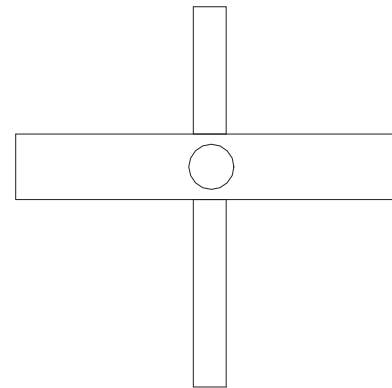

Wash Strainer Separator Weldment
 05700-031-84-38

SECTION 5: PARTS SECTION
STRAINERS

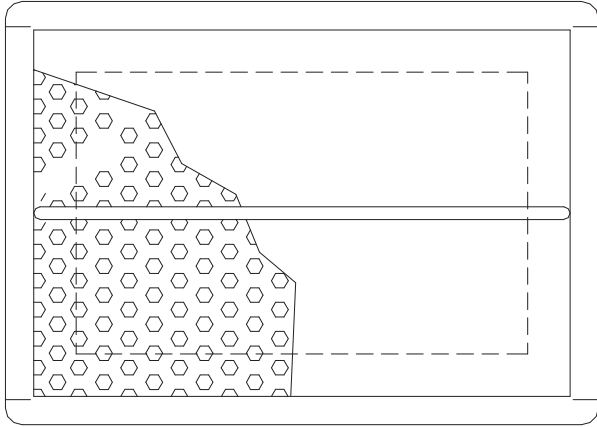

Front Strainer Weldment
05700-021-85-10

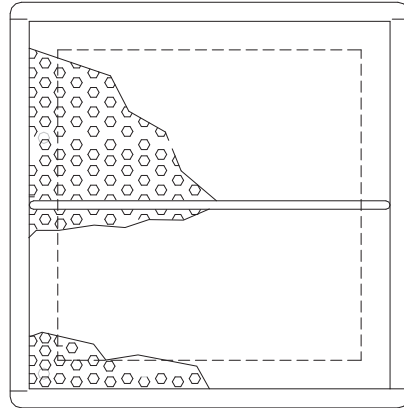

Back Strainer Weldment
05700-021-85-11

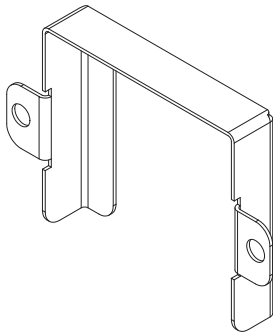

Overflow Strainer Support
05700-001-96-48

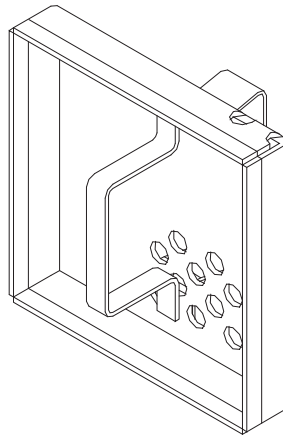

Drain Guard
Strainer Weldment
05700-002-09-15

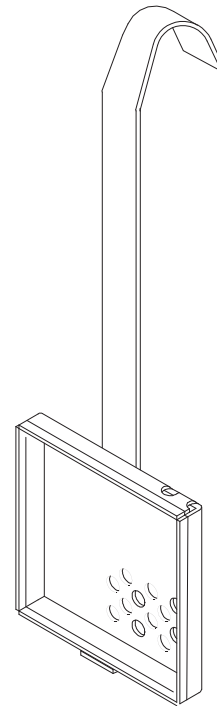

Wash Intake Strainer Weldment (CGP Models)
05700-002-51-52

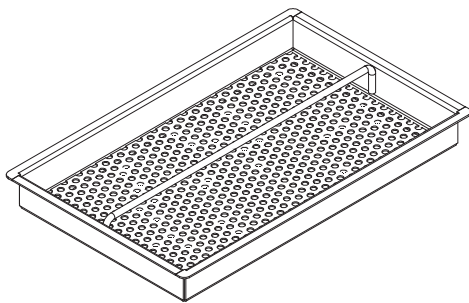

Tub Strainer Weldment (CGP Models)
05700-002-03-21

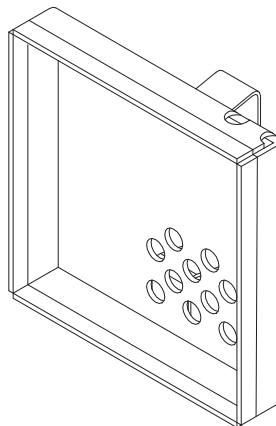

Screen Strainer
with Handle Weldment
05700-002-09-04

SECTION 5: PARTS SECTION
FLOAT SWITCH COMPONENTS/SCRAP BASKETS

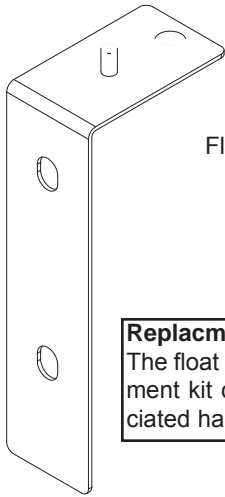

Float Switch Support Bracket
Replacement Kit
06401-003-11-77

Replacement Kit Note:
The float switch support bracket replacement kit contains the bracket and associated hardware for mounting.

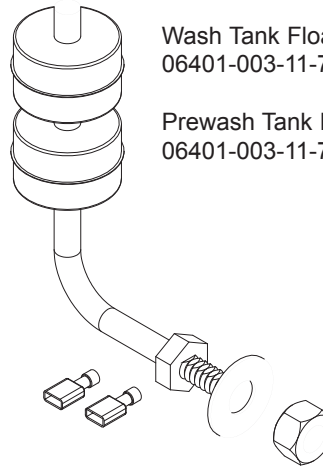

Wash Tank Float Switch Replacement Kit
06401-003-11-75

Prewash Tank Float Switch Replacement Kit
06401-003-11-76

Replacement Kit Note:
The float switch replacement kits contain the float switch with associated terminals, the flat washer and the nut.

Service Agent Note:
Remember than when reinstalling the float switch that the flat washer goes inside against the tub wall while the nut is on the outside of the tub.

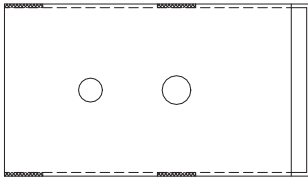

Float Switch Cover
05700-021-75-71

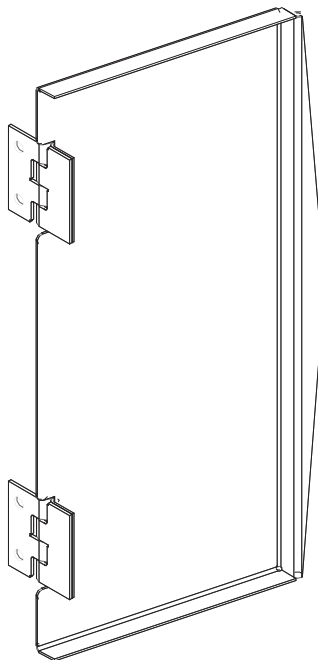

Scrap Basket Lid
Weldment
05700-002-56-55

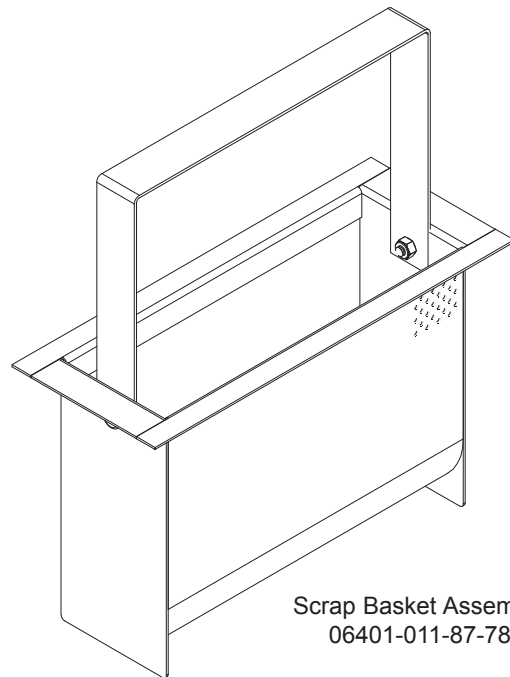

Scrap Basket Assembly
06401-011-87-78

SECTION 5: PARTS SECTION
CURTAINS/TUB MAGNETS

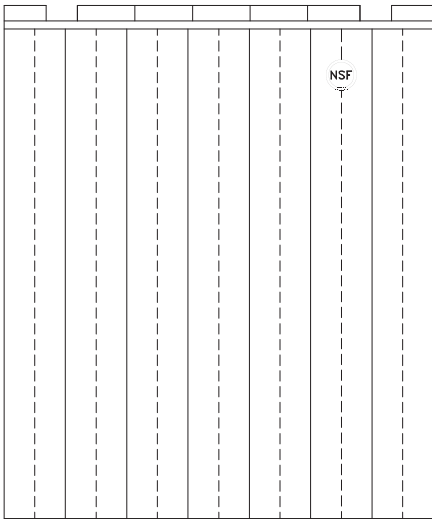

Curtain, 24 1/2" Long x 20-1/2" Wide
CGP MODELS ONLY
08415-002-47-37

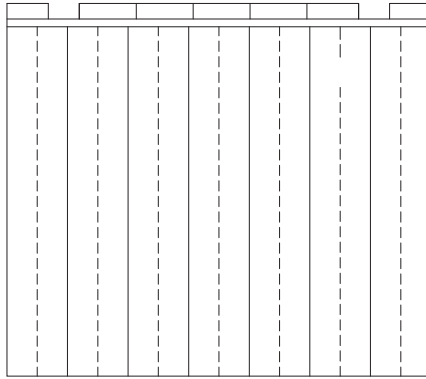

Curtain, 21" Long x 20-1/2" Wide
08415-131-73-45



Long Curtain Decal
09905-011-73-84

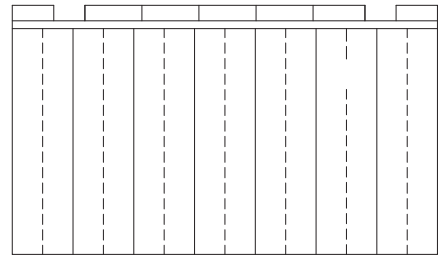

Curtain, 12" Long x 20-1/2" Wide
08415-131-73-44



Short Curtain Decal
09905-011-73-82

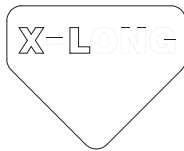

Extra Long Curtain Decal
CGP MODELS ONLY
09905-002-52-69

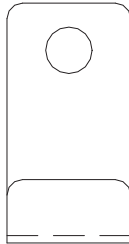

Curtain Hook
05700-011-83-54

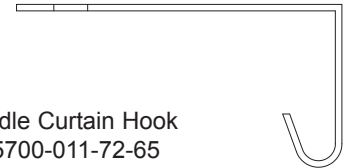

Middle Curtain Hook
05700-011-72-65



Curtain Rod
05700-021-73-43

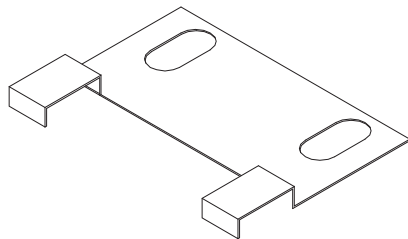

Limit Switch Bracket
05700-021-71-18

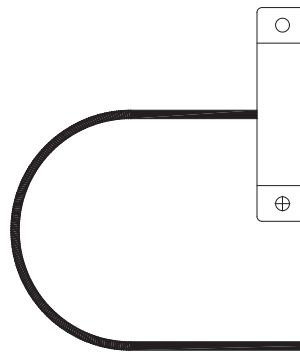

Conveyor Switch Replacement Kit
06401-003-11-79

Replacement Kit Note:
The conveyor switch replacement kit comes with the switch, a terminal and a wire nut.

Service Note:
The cord for the conveyor switch needs to be cut to length in the field and have the pink terminal applied there.

SECTION 5: PARTS SECTION
VENT COWL ASSEMBLY/VENT SCOOP OPTION

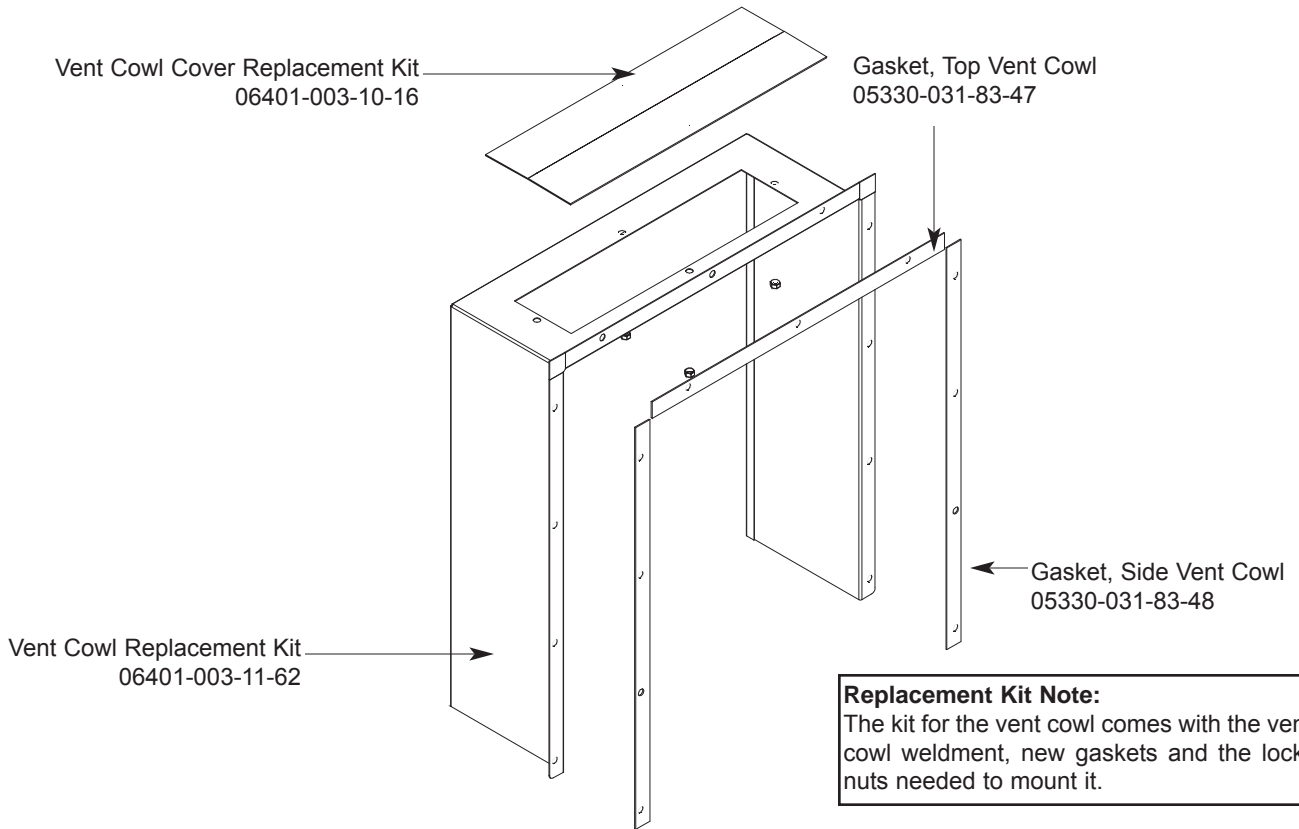

VENT SCOOP OPTION

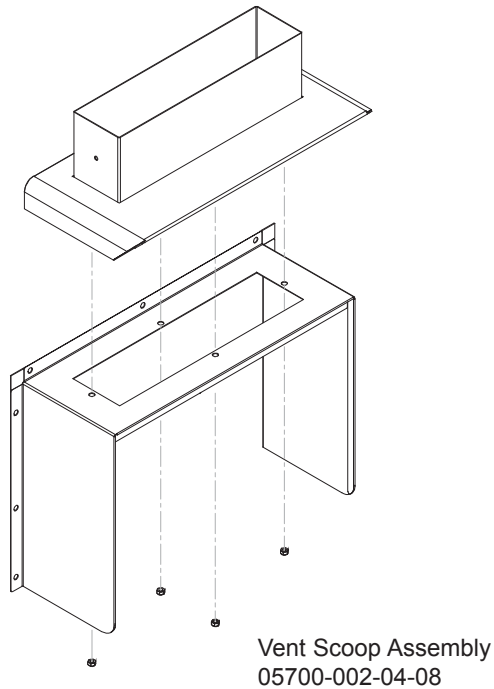

SECTION 5: PARTS SECTION

EXHAUST FAN CONTROL/TABLE LIMIT SWITCH OPTIONS

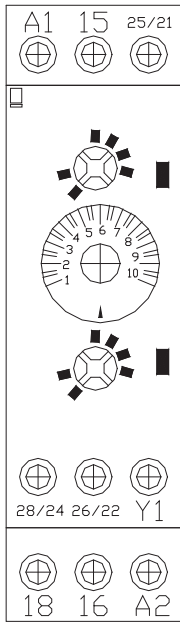

Delay Timer
05945-011-65-44

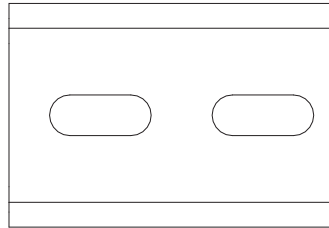

2" Din Rail
05700-002-36-09

**FAN LOAD ON TIMER OUTPUT
5A, 1/4HP, 240 V AC MAX**

Decal, Fan Load
09905-003-32-20

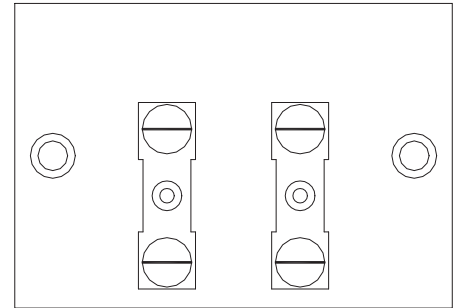

Terminal Board
05940-011-84-41

Kit, Exhaust Fan - Electric & Steam Models
05700-031-90-53

Kit, Exhaust Fan - Gas Models
05700-003-14-59

Limit Switch
05930-002-62-81

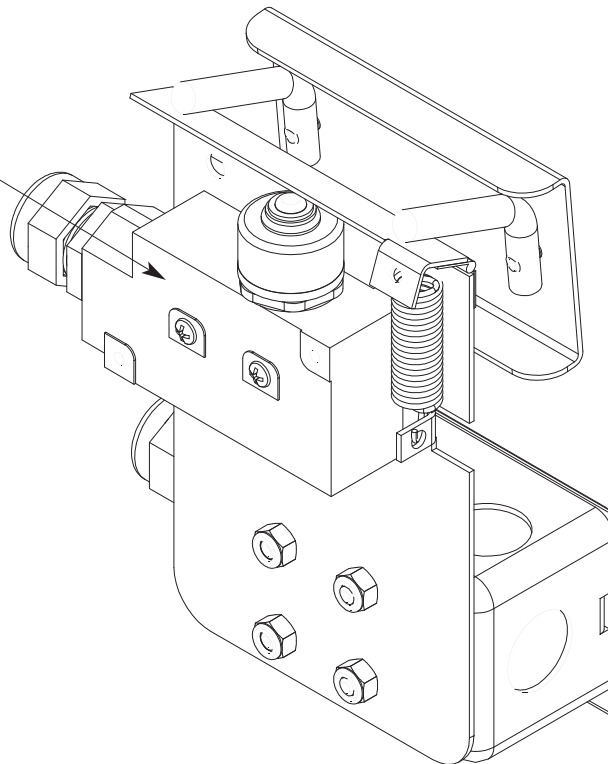

Striker Plate Limit Switch
Assembly
05700-002-62-94

SECTION 5: PARTS SECTION

SIDE LOADER TRACK ASSEMBLY/LEG REPLACEMENTS/STRAINER

Side loader track assembly
(left to right model shown).

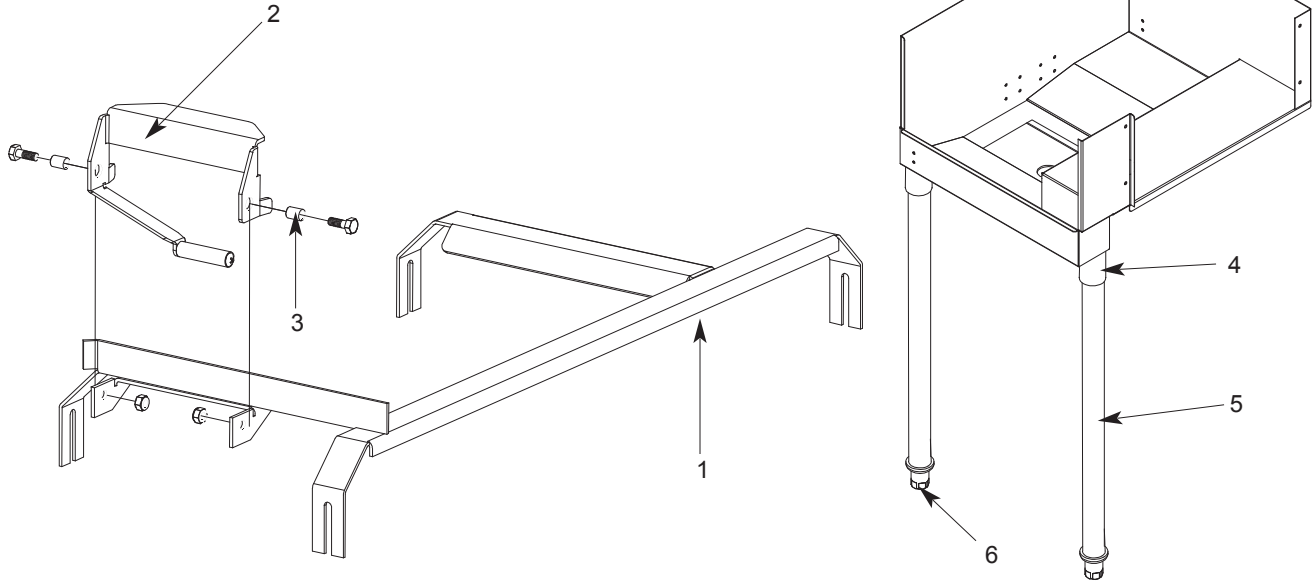

ITEM	QTY	DESCRIPTION	Mfg. No.
1	1	Track Weldment (Left to Right) 24"	05700-031-78-98
	1	Track Weldment (Right to Left) 24"	05700-031-95-20
	1	Track Weldment (Left to Right) 30"	05700-003-04-57
	1	Track Weldment (Right to Left) 30"	05700-003-04-58
2	1	Actuator Switch Replacement Kit	06401-003-10-64
3	2	Spacer	05700-011-71-44
4	1	Leg Socket Replacement Kit	06401-003-09-79
5	1	Leg Support Replacement Kit	06401-003-09-80
6	1	Bullet Foot	05340-108-01-03

Replacement Kits Notes:

The actuator switch replacement kit comes with the actuator weldment, mounting hardware and (2) spacers.

The leg socket replacement kit has the leg socket, mounting hardware and set screw.

The leg support replacement kit has the leg and the bullet foot included.

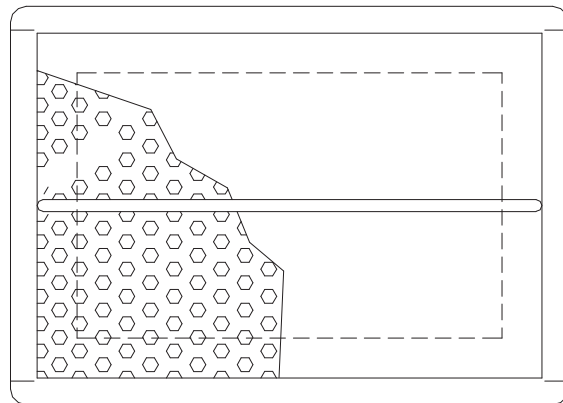

Front Strainer Weldment
05700-021-85-10

SECTION 5: PARTS SECTION

SIDE LOADER PAWL BAR ASSEMBLIES/PAWL BAR BRACKET/MAGNET

Replacement Kit Note:
The kits for the pawl bars come with the bar weldment, (3) dogs and the hardware.

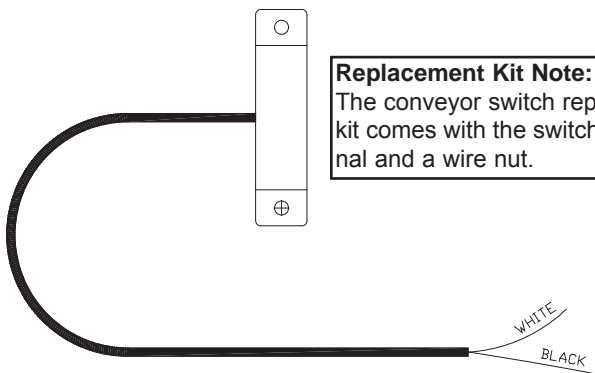
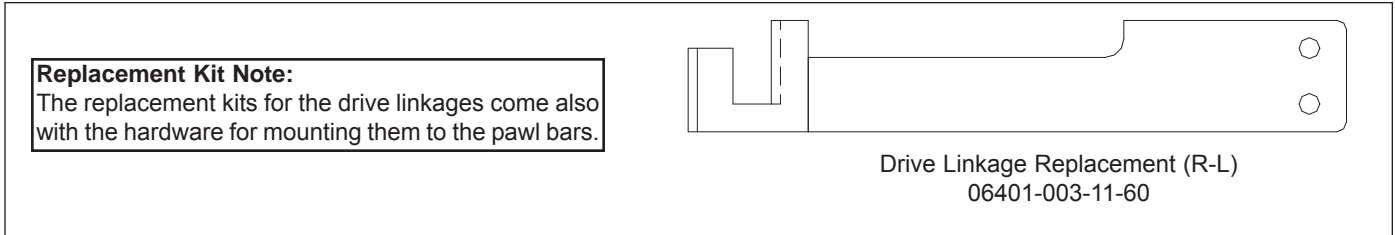
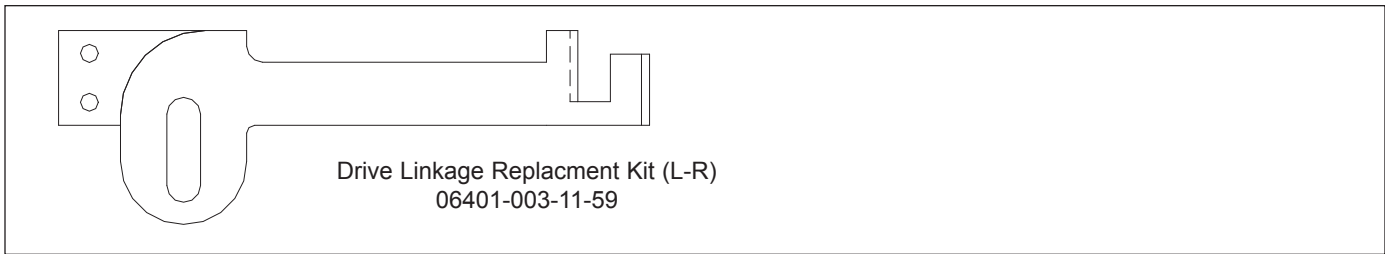
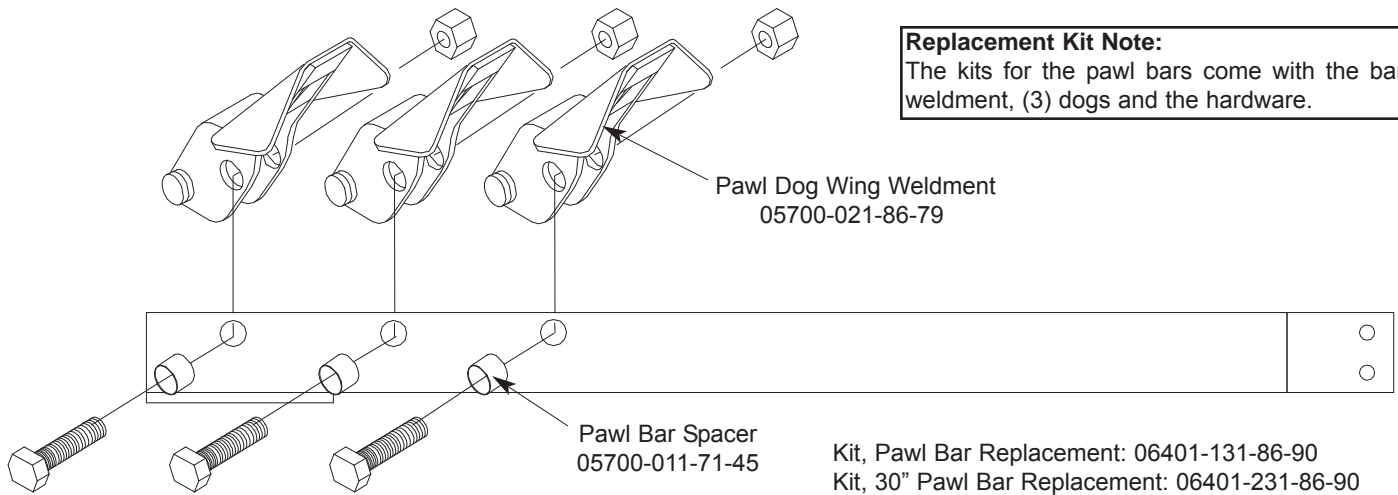

Replacement Kit Note:
The conveyor switch replacement kit comes with the switch, a terminal and a wire nut.

Service Note:
The cord for the conveyor switch needs to be cut to length in the field and have the pink terminal applied there.

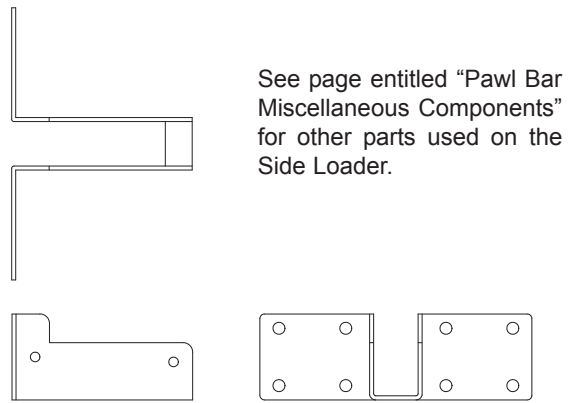

See page entitled "Pawl Bar Miscellaneous Components" for other parts used on the Side Loader.

SECTION 5: PARTS SECTION
SIDE LOADER VENT COWL OPTION

Service Note:
 One of the side gaskets that come in the kit will need to be cut to length in order to fit properly on the unit when replaced.

Vent Cowl Replacement Kit (Left to Right)
 06401-003-11-81

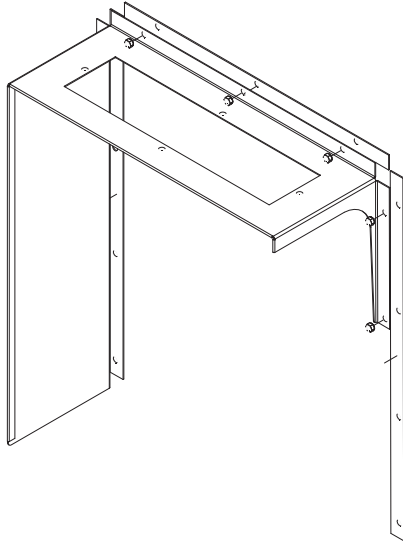

Vent Cowl Replacement Kit (Right to Left)
 06401-003-11-83

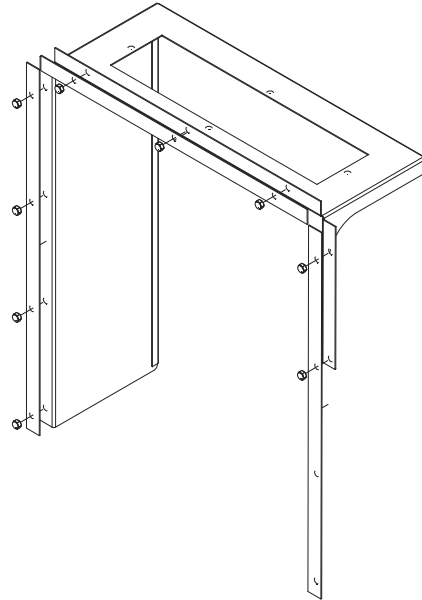

Replacement Kit Note:
 The replacement kit(s) for the vent cowls come with the cowls, the gaskets and mounting hardware.

Vent Cowl Gasket, Top: 05330-031-83-47
 Vent Cowl Gasket, Side: 05330-031-83-48

VENT SCOOP OPTION
 Vent Scoop Assembly
 05700-002-04-08

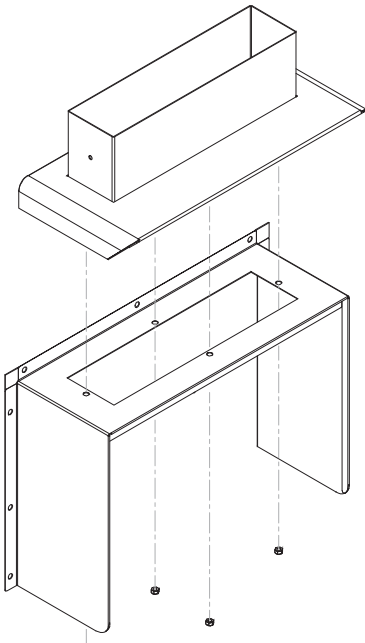

STANDARD ASSEMBLY
 Vent Cowl Cover Replacement Kit
 06401-003-10-16

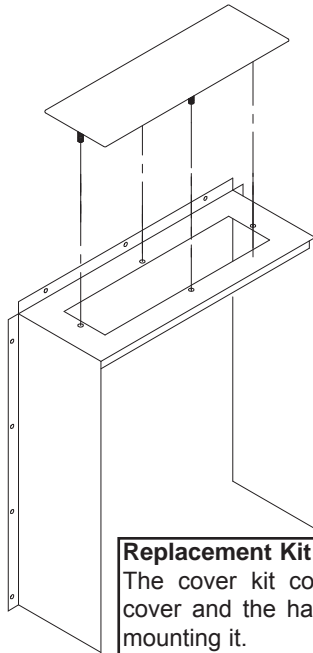

Replacement Kit Note:
 The cover kit contains the cover and the hardware for mounting it.

Vent Cowl Assembly for
 Hooded Side Loader Option
 05700-003-15-66

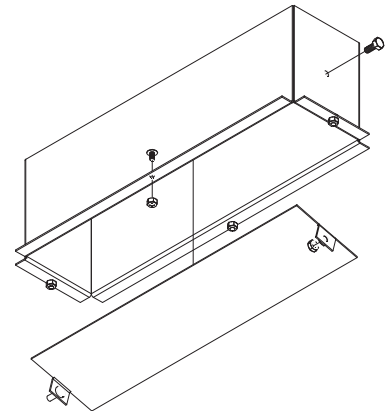

SECTION 5: PARTS SECTION
D226 STEAM BOOSTER CONTROL BOX ASSEMBLY

Decal, Schematic, D226 Booster (on the inside of the control box cover) 09905-002-78-56

Decal, Warning, Disconnect Power 09905-100-75-93

Replacement Kit Note:
 The kit for the terminal block replacement includes the block, the spacer and the locknut.

Control Box Cover Replacement Kit 06401-003-11-63

Replacement Kit Note:
 The kit for the control box cover comes with the decals and the screws for securing the cover.

Terminal Block Replacement Kit 06401-003-11-78

Decal, L1-L2 09905-002-78-67

Ground Lug 05940-200-76-00

Spacer, Terminal Block

Decal, Ground 09905-011-86-86

Thermostat 06680-500-01-77

Light, Red 05945-111-21-57

Conduit Fitting, .231" x.394" 05975-011-49-03

Power Switch 05930-011-49-55

Control Box with Decal 06401-002-78-87

SECTION 5: PARTS SECTION
D226 STEAM BOOSTER PLUMBING ASSEMBLY

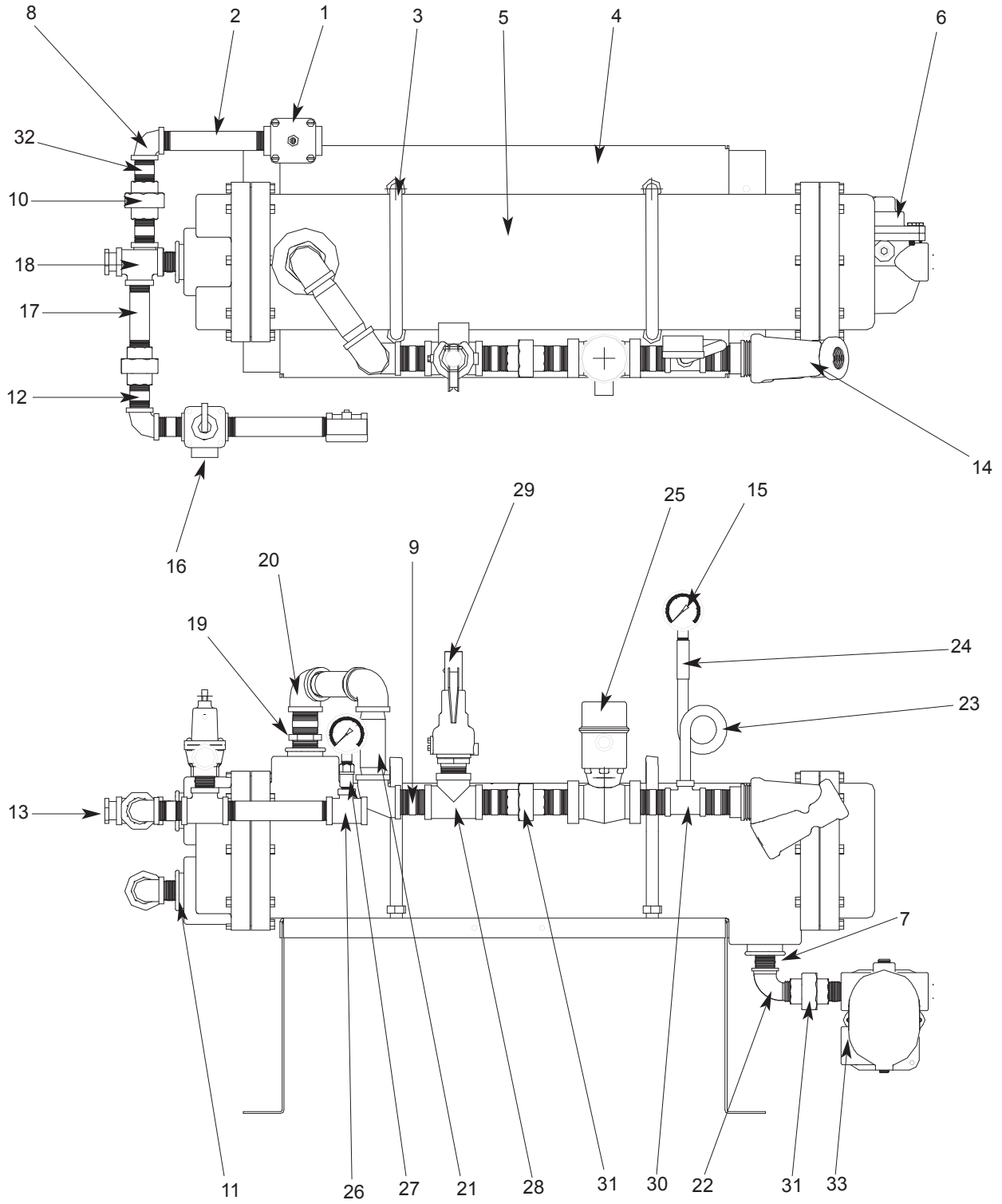

SECTION 5: PARTS SECTION**D226 STEAM BOOSTER PLUMBING ASSEMBLY (CONTINUED)**

ITEM	QTY	DESCRIPTION	Mfg. No.
1	1	Water Pressure Regulator, 3/4"	04820-100-01-06
2	2	Nipple, Brass, 3/4" NPT x 6" Long	05700-001-26-74
3	2	U-Bolt, 6", 5/8"-11 Thread	05306-458-01-04
4	1	Platform Weldment	05700-002-78-02
5	1	Heat Exchanger	04420-100-01-05
6	1	Steam Trap, 3/4"	06680-500-02-77
7	1	Bushing, 2" NPT x 3/4" NPT, Black Iron	04730-902-06-34
8	2	Elbow, 3/4" NPT, Brass	04730-206-13-00
9	6	Nipple, 1" NPT, Close, Black Iron	04730-907-08-34
10	2	Union, 3/4" NPT, Brass	04730-212-05-00
11	2	Bushing, 2" NPT x 3/4" NPT, Brass	04730-202-18-00
12	4	Nipple, 3/4" NPT x 1-3/8" Long	04730-207-34-00
13	1	Bushing, Hex 3/4" M x 1/2" F, Brass	04730-002-56-27
14	1	Y-Strainer, 1" NPT, Black Iron	04730-217-02-32
15	2	Pressure Gauge	06685-111-88-34
16	1	Steam Relief Valve	04820-100-07-06
17	2	Nipple, 3/4" NPT x 4" Long, Brass	04730-207-05-00
18	2	Tee, 3/4" NPT x 3/4" NPT x 3/4" NPT, Brass	04730-211-01-34
19	1	Bushing, 2" NPT x 1" NPT, Black Iron	04730-002-94-51
20	3	Elbow, 90°, 1" NPT, Black Iron	04730-906-03-34
21	2	Nipple, 1" NPT x 4" Long, Black Iron	04730-907-09-34
22	1	Elbow, 90°, Street, 3/4" NPT, Black Iron	04730-011-87-37
23	1	Nipple, Pigtail, 1/4" NPT	04730-907-14-34
24	1	Coupling, 1/4" NPT x 1/4" NPT	04730-904-01-34
25	1	Steam Solenoid Valve, 240VA	04820-100-29-34
25	1	Steam Solenoid Valve, 200VA	04820-002-93-66
25	1	Steam Solenoid Valve (ASCO)	04820-002-90-26
26	1	Tee, 3/4" NPT x 3/4" NPT x 1/4" NPT, Brass	04730-211-04-00
27	1	Valve, Test Cock, 1/4" NPT	04810-011-72-67
28	1	Tee, 1" NPT x 1" NPT x 1" NPT, Black Iron	04730-911-01-34
29	1	Valve, Safety Relief 1" NPT	04820-100-01-35
30	1	Tee, 1" NPT x 1" NPT x 1/4" NPT, Black Iron	04730-911-01-00
31	2	Union, 3/4" NPT, Black Iron	04730-912-01-00
32	2	Nipple, 3/4" NPT x 2" Long, Brass	04730-207-46-00
33	2	Nipple, 3/4" NPT, Close, Black Iron	04730-907-01-00

SECTION 5: PARTS SECTION

GO*BOX COMPONENTS

A GO*BOX is a kit of the most needed parts for a particular model or model family to successfully effect a repair in the first call 90% or more of the time.

The following components may be ordered together using part number 06401-002-14-99.

QTY	DESCRIPTION	Mfg. No.
1	Drive Motor Contactor	05945-111-68-38
1	Contactora, Wash Heater, 3 ph, 3 pole	05945-002-24-70
1	Contactora, Wash Heater, 1 ph, 4 pole	05945-111-68-37
2	Final Rinse Arm End Cap	05700-011-35-92
1	Float Switch, Dual, Wash & Prewash	06680-121-70-71
1	Gasket, Pawl Bar Gutter	05330-011-68-55
1	Gauge, Pressure	06685-111-88-34
6	Glide, Door Edge	05700-111-70-92
2	Magnet, Door Reed Switch	05930-111-51-68
2	O Ring, Prewash Manifold	05330-400-12-08
2	O Ring, Wash Manifold	05330-011-74-56
1	Overload, Drive Motor	05945-111-68-39
1	Overload, Wash Motor	05945-111-68-40
1	Relay, 120v, 3 PDT	05945-111-72-51
1	Relay, 120v, 50/60Hz 3A Control	05945-111-35-19
1	Repair Kit, 3/4" Vacuum Breaker	04820-001-60-57
4	Roller, Pawl Bar	05700-011-68-16
1	Seal Kit for Wash and Prewash pump	05330-011-71-98
2	Solenoid Valve, Fill & Rinse	04810-100-53-00
2	Switch, Power	05930-011-49-55
2	Switch, Reed, Actuator (NC)	05930-111-68-44
1	Switch, Reed, Door (NO)	05930-111-68-86
1	Thermometer, 48" Capillary	06685-111-68-48
1	Thermometer, 96" Capillary	06685-111-68-49
2	Thermostat, Wash High Limit	05930-121-71-36
2	Thermostat, Wash Regulating	05930-121-67-72
1	Transformer, 150VA	05950-011-68-35
1	Valve, Ball 1 1/2" NPT	04820-111-71-46

SECTION 5: PARTS SECTION

RINSE FILL MOTOR OPTION

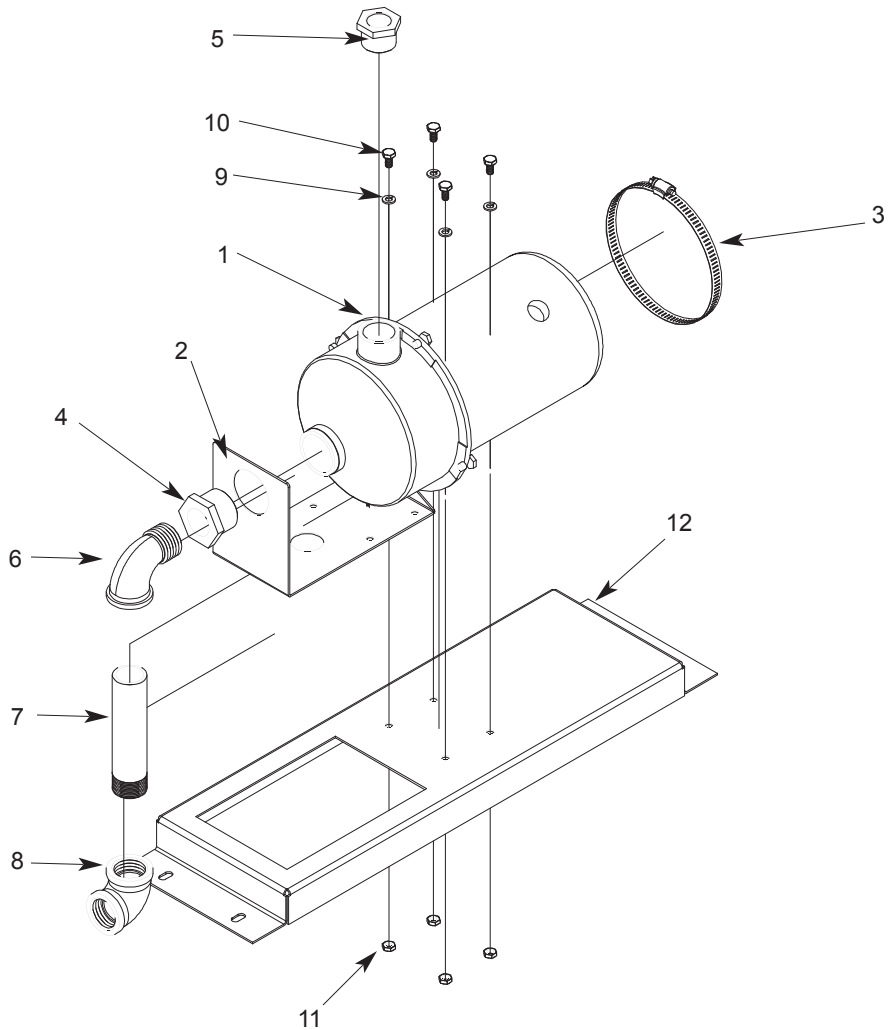

ITEM	QTY	DESCRIPTION	Mfg. No.
	1	Rinse Fill Motor Assembly	05700-002-40-25
1	1	Motor	06105-002-72-71
2	1	Bracket, Pump Mounting	05700-002-63-59
3	1	Clamp, Hose 5 5/8" to 6"	04730-011-34-90
4	1	Reducer Bushing, 1 1/4" to 1"	04730-002-73-62
5	1	Reducer Bushing 1" to 3/4"	04730-011-65-14
6	1	Elbow, 90 Deg., 1" Street	04730-002-11-99
7	1	Nipple, 1" NPT x 6" Long Brass	04730-002-12-00
8	1	Elbow, 90 Deg. Brass Female	04730-002-12-55
9	4	Lockwasher, 1/4"	05311-274-01-00
10	4	Bolt, 1/4"-20 x 1/2" Long	05305-274-02-00
11	4	Nut, Hex S/S 1/4"-20	05310-274-01-00
12	1	Rinse Motor Mounting Bracket	05700-002-38-90

SECTION 6: ELECTRICAL SCHEMATICS

SECTION 6: ELECTRICAL SCHEMATICS

AJ-64CE (208-230 VOLT, 60 HZ, SINGLE PHASE) PRIMARY SIDE

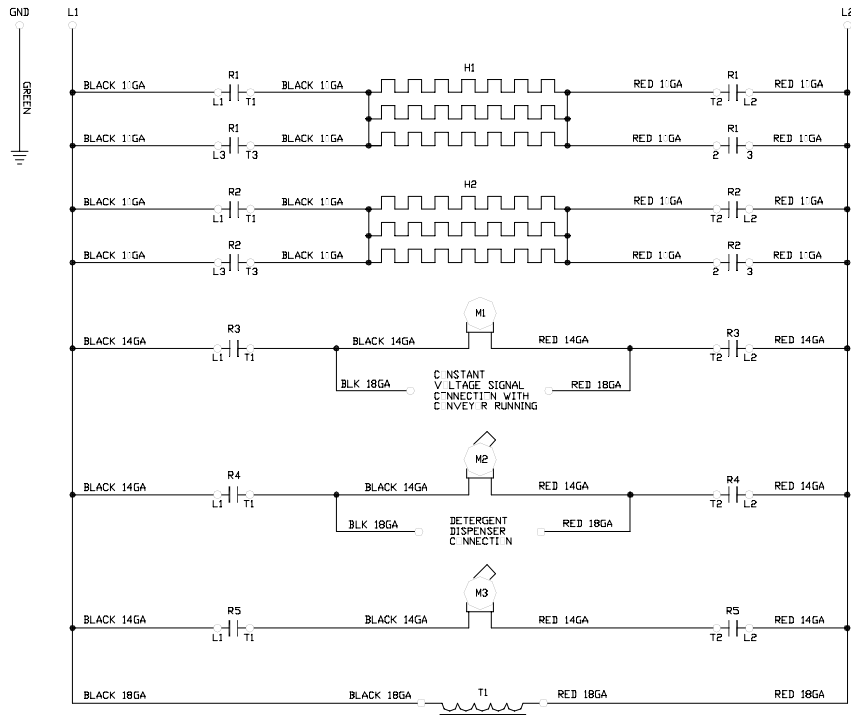

SECTION 6: ELECTRICAL SCHEMATICS

AJ-64CE (208-230 VOLT, 60 HZ, THREE PHASE) PRIMARY SIDE

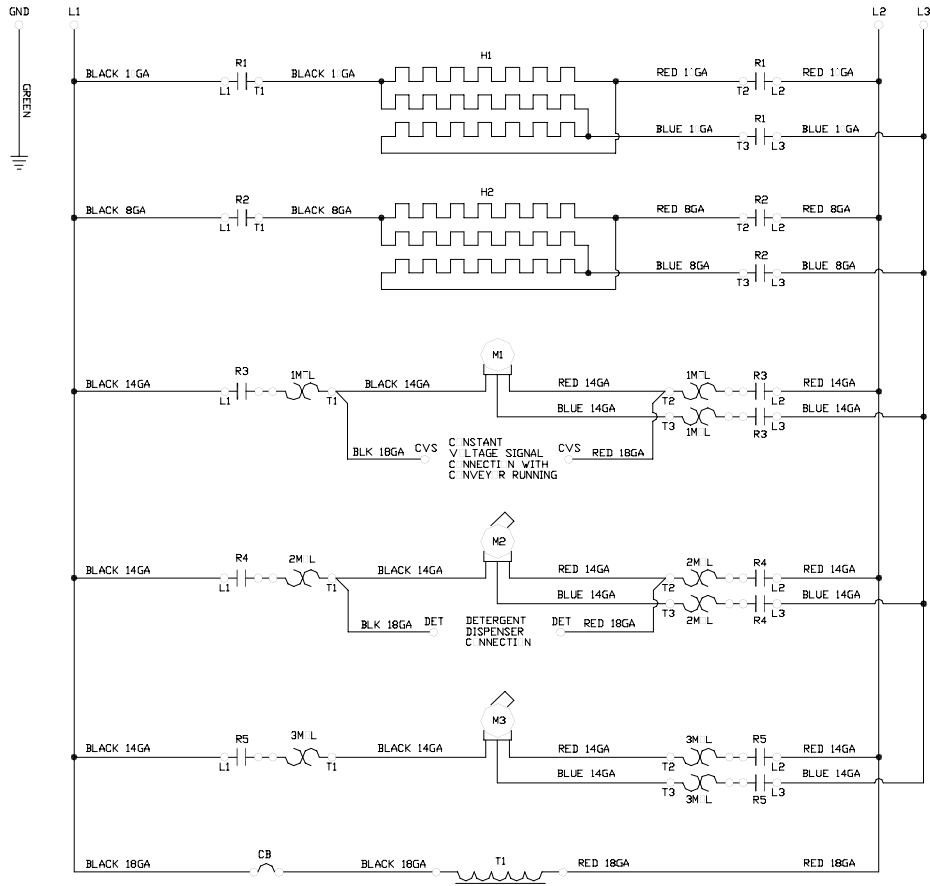

SECTION 6: ELECTRICAL SCHEMATICS

AJ-64CE (208-230 VOLT, 60 HZ, THREE PHASE) SECONDARY SIDE

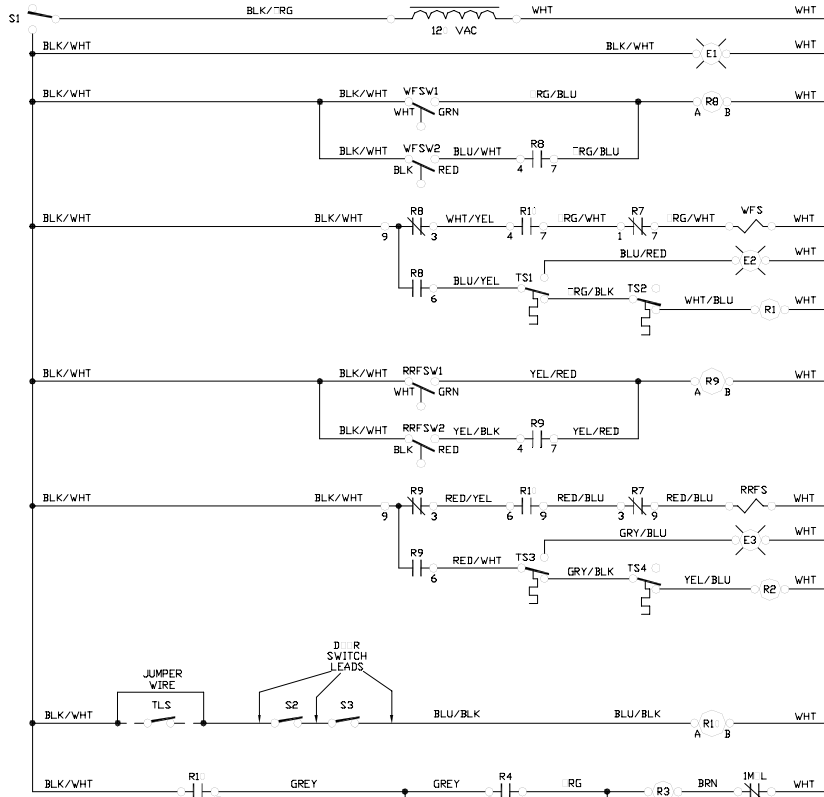

LEGEND

- L1 L2 L3 P WER DISTRIBUTI N BL CK
- GND GR UND
- R1 WASH TANK HEAT C N TACT R
- R2 RECIRCULATING RINSE HEAT C N TACT R
- R3 DRIVE M T R C N TACT R
- R4 WASH PUMP M T R C N TACT R
- R5 RECIRCULATING RINSE PUMP M T R C N TACT R
- R6 FINAL RINSE RELAY #1
- R7 FINAL RINSE RELAY #2
- R8 WASH TANK FILL RELAY
- R9 RECIRCULATING RINSE TANK FILL RELAY
- R10 D I R SAFETY SWITCH RELAY
- H1 WASH HEATER
- H2 RECIRCULATING RINSE HEATER
- M1 DRIVE M T R
- M2 WASH PUMP M T R
- M3 RECIRCULATING RINSE PUMP M T R
- 1M L DRIVE M T R O V E R L A D
- 2M L WASH PUMP M T R O V E R L A D
- 3M L RECIRCULATING RINSE PUMP M T R O V E R L A D
- CB C N T R L C I R C U I T B R E A K E R
- T1 C N T R L T R A N S F O R M E R
- DET D E T E R G E N T D I S P E N S E R C N N E C T I N
- CVS C N S T A N T V L T A G E S I G N A L
- S1 P W E R S W I T C H
- S2 D I R S A F E T Y S W I T C H 1
- S3 D I R S A F E T Y S W I T C H 2
- S4 W A S H P U M P S W I T C H 1
- S5 W A S H P U M P S W I T C H 2
- S6 A U T - M A N / D E L I M E S W I T C H
- S7 R E C I R C U L A T I N G R I N S E P U M P S W I T C H
- S8 F I N A L R I N S E S W I T C H
- E1 P W E R L I G H T
- E2 W A S H H E A T E R H I G H L I M I T L I G H T
- E3 R E C I R C U L A T I N G R I N S E H E A T E R H I G H L I M I T L I G H T
- WFSW1 W A S H F L A T S W I T C H 1
- WFSW2 W A S H F L A T S W I T C H 2
- RRFSW1 R E C I R C U L A T I N G R I N S E F L A T S W I T C H 1
- RRFSW2 R E C I R C U L A T I N G R I N S E F L A T S W I T C H 2
- TS1 W A S H H E A T E R H I G H L I M I T T H E R M S T A T
- TS2 W A S H R E G U L A T I N G T H E R M S T A T
- TS3 R - R I N S E H E A T E R H I G H L I M I T T H E R M S T A T
- TS4 R - R I N S E R E G U L A T I N G T H E R M S T A T
- CWTS C L D W A T E R T H E R M S T A T (P T I N A L)
- CWV C L D W A T E R V A L V E (P T I N A L)
- TLS T A B L E L I M I T S W I T C H (P T I N A L)
- WFS W A S H F I L L S L E N I D
- RRFS R E C I R C U L A T I N G R I N S E F I L L S L E N I D
- RS F I N A L R I N S E S L E N I D

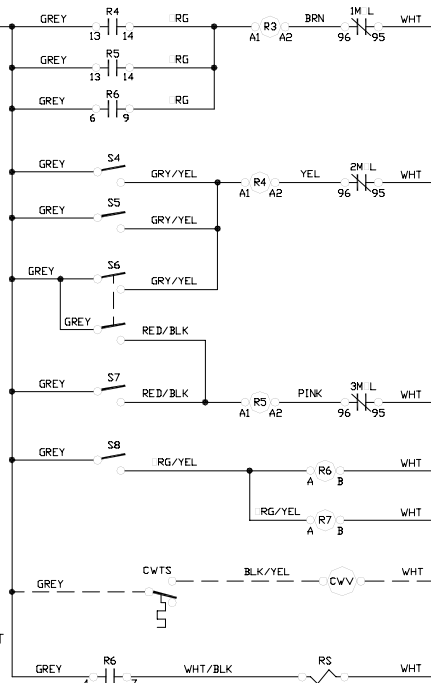

99 5-31-82-66

SECTION 6: ELECTRICAL SCHEMATICS

AJ-64CE (460 VOLT, 60 HZ, THREE PHASE) PRIMARY SIDE

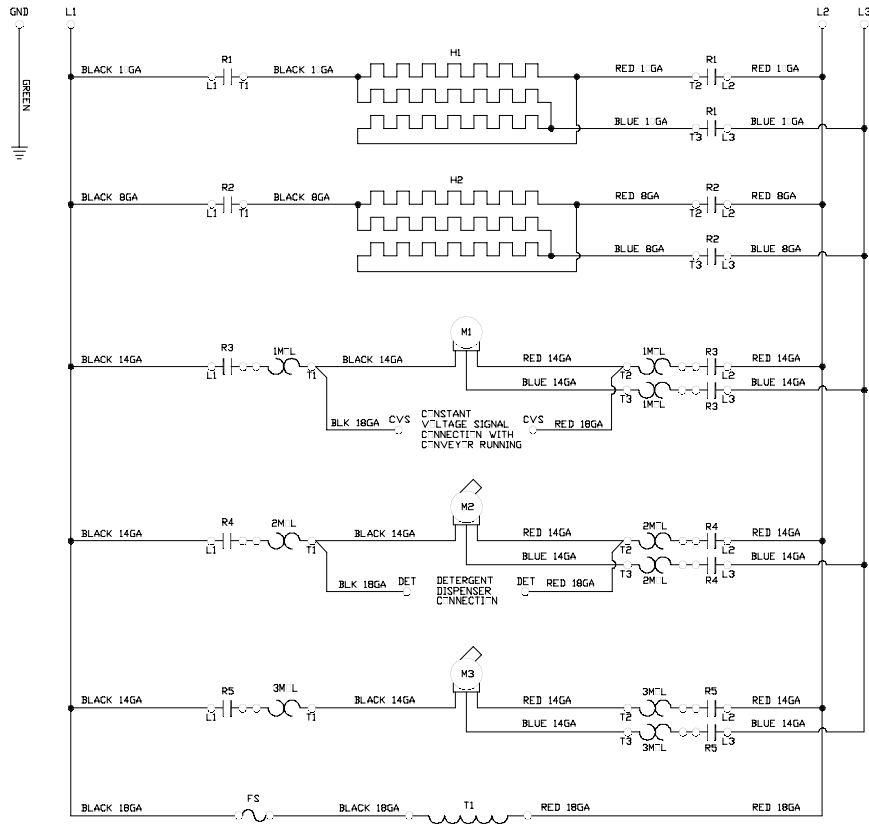

SECTION 6: ELECTRICAL SCHEMATICS

AJ-64CE (460 VOLT, 60 HZ, THREE PHASE) SECONDARY SIDE

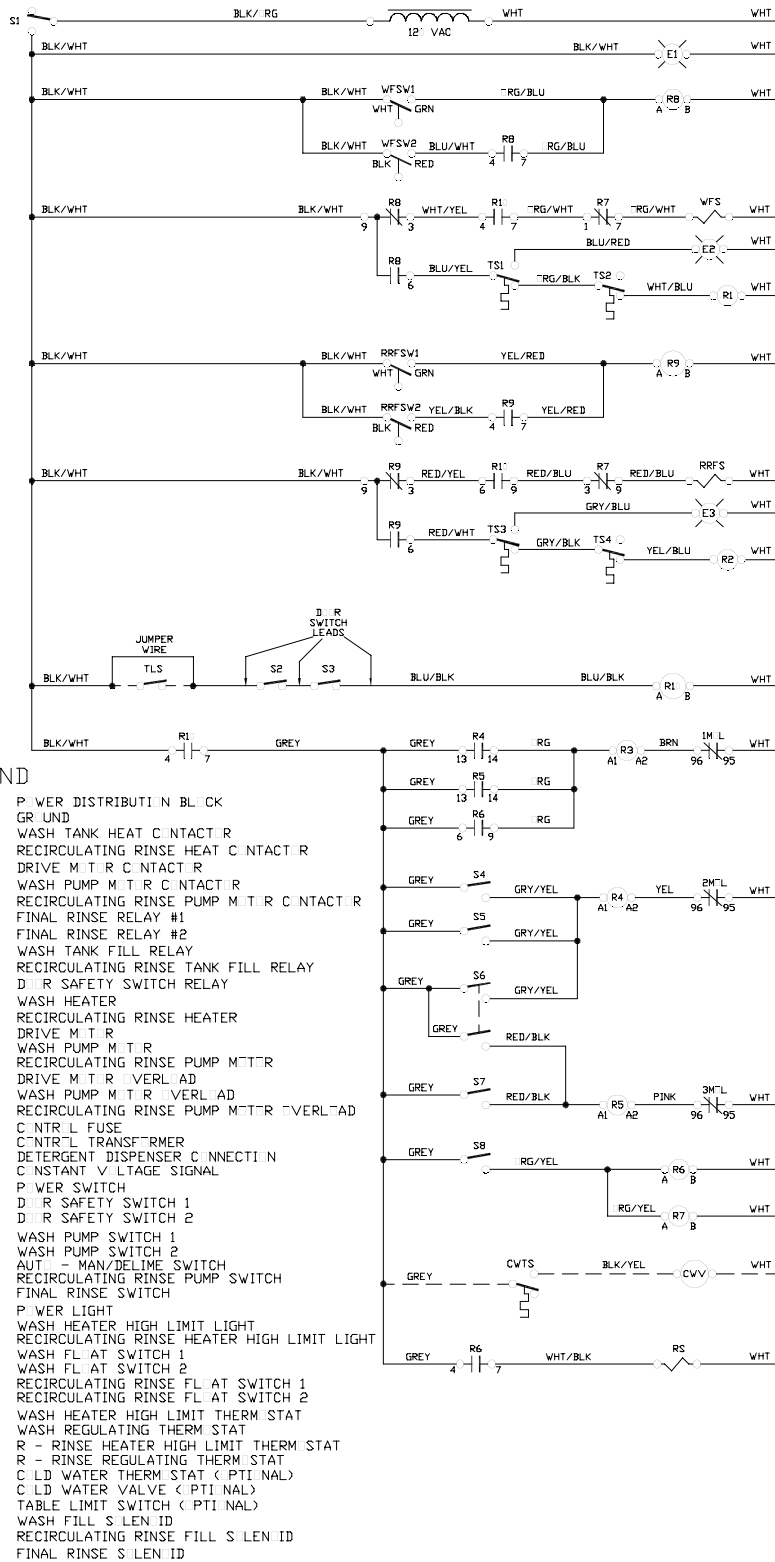

09905-031-95-56

SECTION 6: ELECTRICAL SCHEMATICS

AJ-64CS (208-230 VOLT, 60 HZ, SINGLE PHASE) PRIMARY SIDE

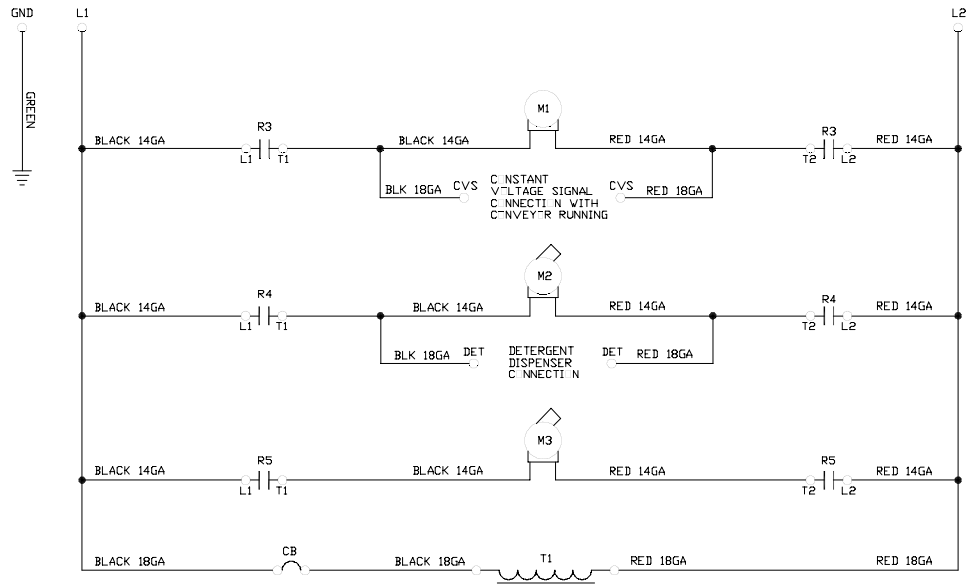

SECTION 6: ELECTRICAL SCHEMATICS

AJ-64CS (208-230 VOLT, 60 HZ, SINGLE PHASE) SECONDARY SIDE

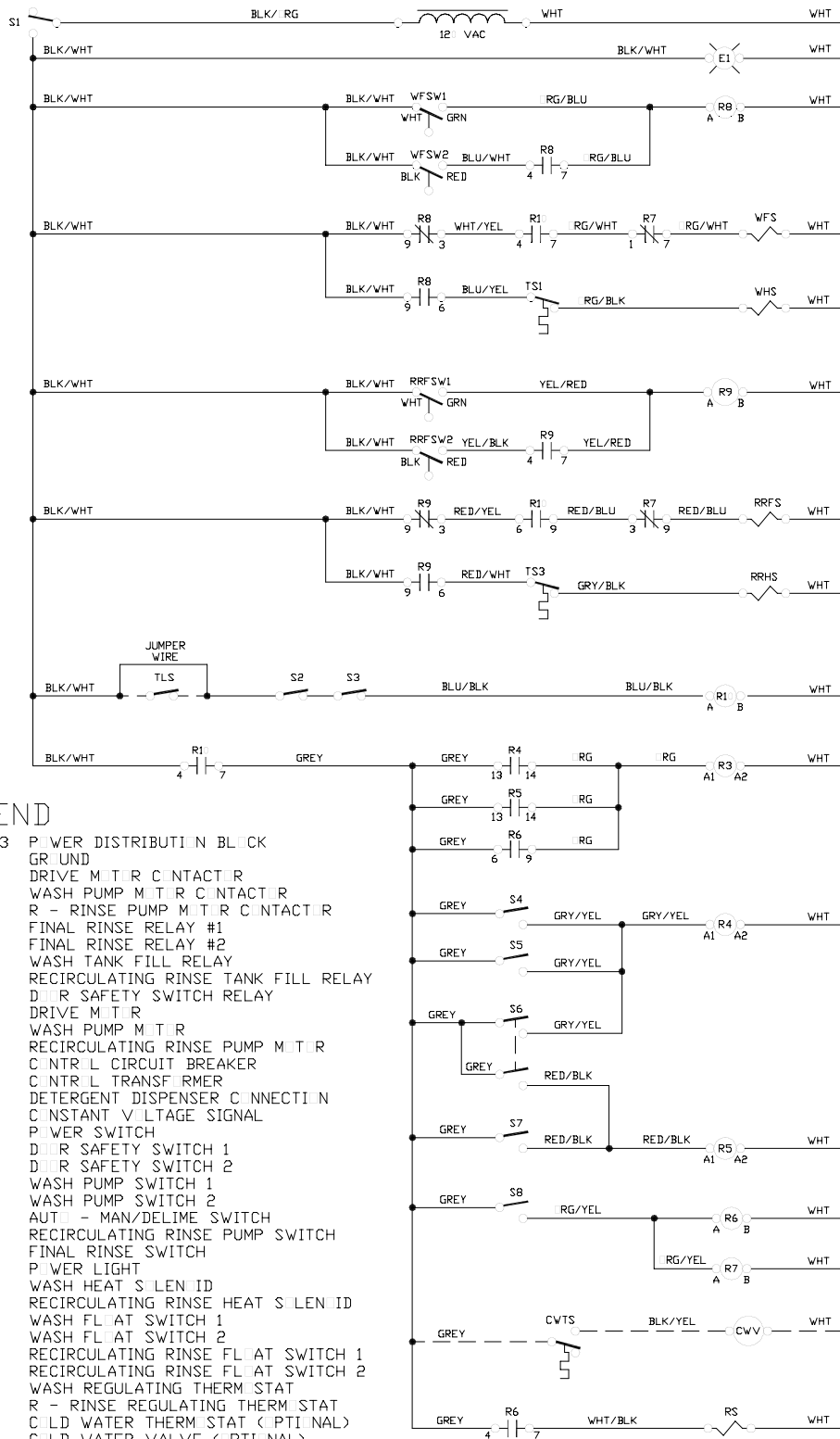

LEGEND

L1 L2 L3	POWER DISTRIBUTION BLOCK
GND	GROUND
R3	DRIVE MOTOR CONTACTOR
R4	WASH PUMP MOTOR CONTACTOR
R5	R - RINSE PUMP MOTOR CONTACTOR
R6	FINAL RINSE RELAY #1
R7	FINAL RINSE RELAY #2
R8	WASH TANK FILL RELAY
R9	RECIRCULATING RINSE TANK FILL RELAY
R10	DOOR SAFETY SWITCH RELAY
M1	DRIVE MOTOR
M2	WASH PUMP MOTOR
M3	RECIRCULATING RINSE PUMP MOTOR
CB	CENTRAL CIRCUIT BREAKER
T1	CENTRAL TRANSFORMER
DET	DETERGENT DISPENSER CONNECTION
CVS	CONSTANT VOLTAGE SIGNAL
S1	POWER SWITCH
S2	DOOR SAFETY SWITCH 1
S3	DOOR SAFETY SWITCH 2
S4	WASH PUMP SWITCH 1
S5	WASH PUMP SWITCH 2
S6	AUT - MAN/DELIMITE SWITCH
S7	RECIRCULATING RINSE PUMP SWITCH
S8	FINAL RINSE SWITCH
E1	POWER LIGHT
WHS	WASH HEAT SILEN ID
RRHS	RECIRCULATING RINSE HEAT SILEN ID
WFSW1	WASH FLAT SWITCH 1
WFSW2	WASH FLAT SWITCH 2
RRFSW1	RECIRCULATING RINSE FLAT SWITCH 1
RRFSW2	RECIRCULATING RINSE FLAT SWITCH 2
TS1	WASH REGULATING THERM STAT
TS3	R - RINSE REGULATING THERM STAT
CWTS	COLD WATER THERM STAT (PTI NAL)
CWV	COLD WATER VALVE (PTI NAL)
TL5	TABLE LIMIT SWITCH (PTI NAL)
WFS	WASH FILL SILEN ID
RRFS	RECIRCULATING RINSE FILL SILEN ID
RS	FINAL RINSE SILEN ID

9905-002-55-96a

SECTION 6: ELECTRICAL SCHEMATICS

AJ-64CS (208-230 VOLT, 60 HZ, THREE PHASE) PRIMARY SIDE

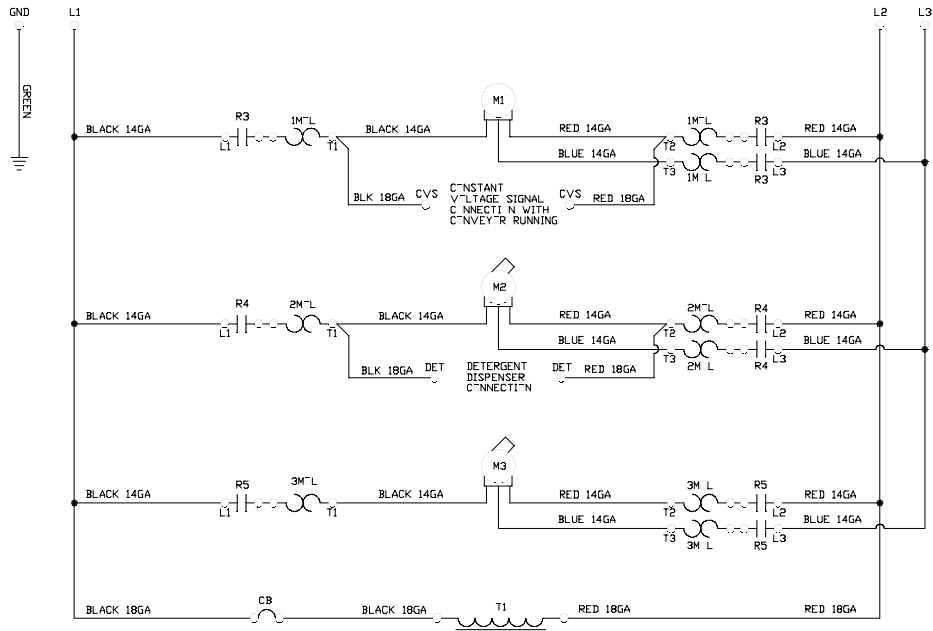

SECTION 6: ELECTRICAL SCHEMATICS

AJ-64CS (208-230 VOLT, 60 HZ, THREE PHASE) SECONDARY SIDE

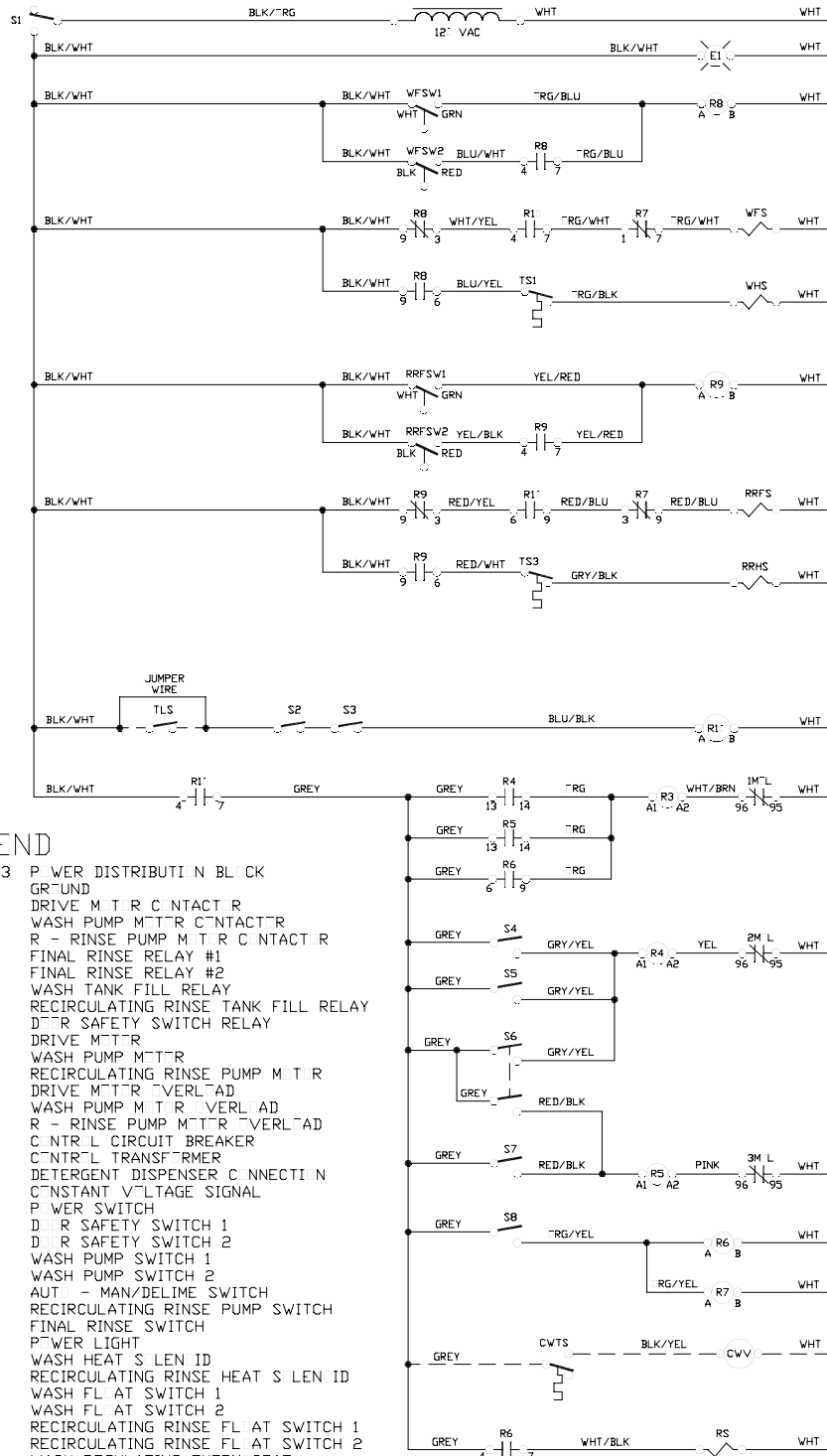

LEGEND

- L1 L2 L3 POWER DISTRIBUTION BLOCK
- GND GROUND
- R3 DRIVE MOTOR CONTACTOR
- R4 WASH PUMP MOTOR CONTACTOR
- R5 R - RINSE PUMP MOTOR CONTACTOR
- R6 FINAL RINSE RELAY #1
- R7 FINAL RINSE RELAY #2
- R8 WASH TANK FILL RELAY
- R9 RECIRCULATING RINSE TANK FILL RELAY
- R10 DRIVE SAFETY SWITCH RELAY
- M1 DRIVE MOTOR
- M2 WASH PUMP MOTOR
- M3 RECIRCULATING RINSE PUMP MOTOR
- 1M^L DRIVE MOTOR OVERLOAD
- 2M^L WASH PUMP MOTOR OVERLOAD
- 3M^L R - RINSE PUMP MOTOR OVERLOAD
- CB CONTROL CIRCUIT BREAKER
- T1 CONTROL TRANSFORMER
- DET DETERGENT DISPENSER CONNECTION
- CVS CONSTANT VOLTAGE SIGNAL
- S1 POWER SWITCH
- S2 DRIVE SAFETY SWITCH 1
- S3 DRIVE SAFETY SWITCH 2
- S4 WASH PUMP SWITCH 1
- S5 WASH PUMP SWITCH 2
- S6 AUT - MAN/DELTIME SWITCH
- S7 RECIRCULATING RINSE PUMP SWITCH
- S8 FINAL RINSE SWITCH
- E1 POWER LIGHT
- WHS WASH HEAT SLENIID
- RRHS RECIRCULATING RINSE HEAT SLENIID
- WFSW1 WASH FLAT SWITCH 1
- WFSW2 WASH FLAT SWITCH 2
- RRFSW1 RECIRCULATING RINSE FLAT SWITCH 1
- RRFSW2 RECIRCULATING RINSE FLAT SWITCH 2
- TS1 WASH REGULATING THERMISTAT
- TS3 R - RINSE REGULATING THERMISTAT
- CWTS COLD WATER THERMISTAT (PTINAL)
- CWV COLD WATER VALVE (PTINAL)
- TLS TABLE LIMIT SWITCH (PTINAL)
- WFS WASH FILL SLENIID
- RRFS RECIRCULATING RINSE FILL SLENIID
- RS FINAL RINSE SLENIID

99 5-12-17-6.

SECTION 6: ELECTRICAL SCHEMATICS

AJ-64CS (460 VOLT, 60 HZ, THREE PHASE) PRIMARY SIDE

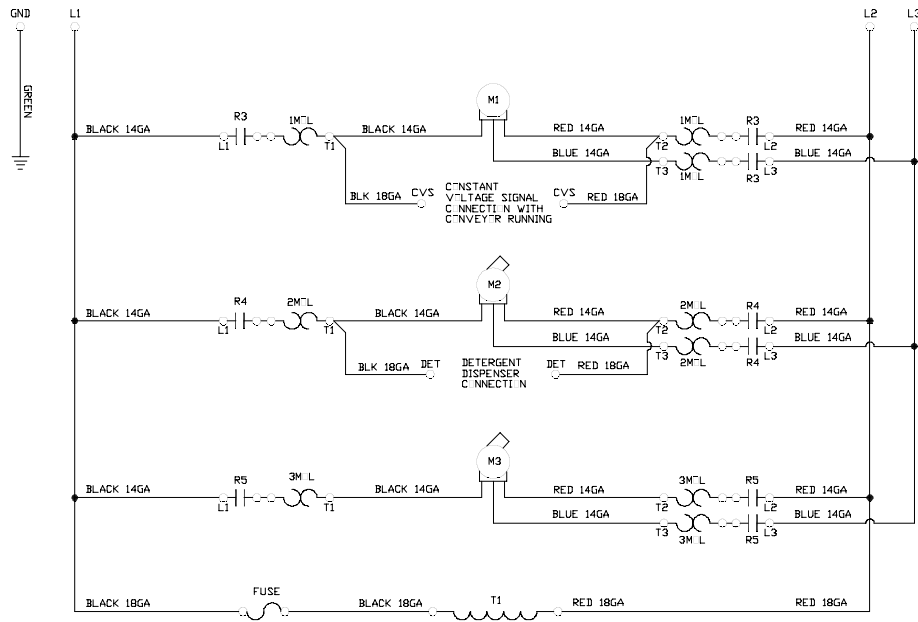

SECTION 6: ELECTRICAL SCHEMATICS

AJ-64CS (460 VOLT, 60 HZ, THREE PHASE) SECONDARY SIDE

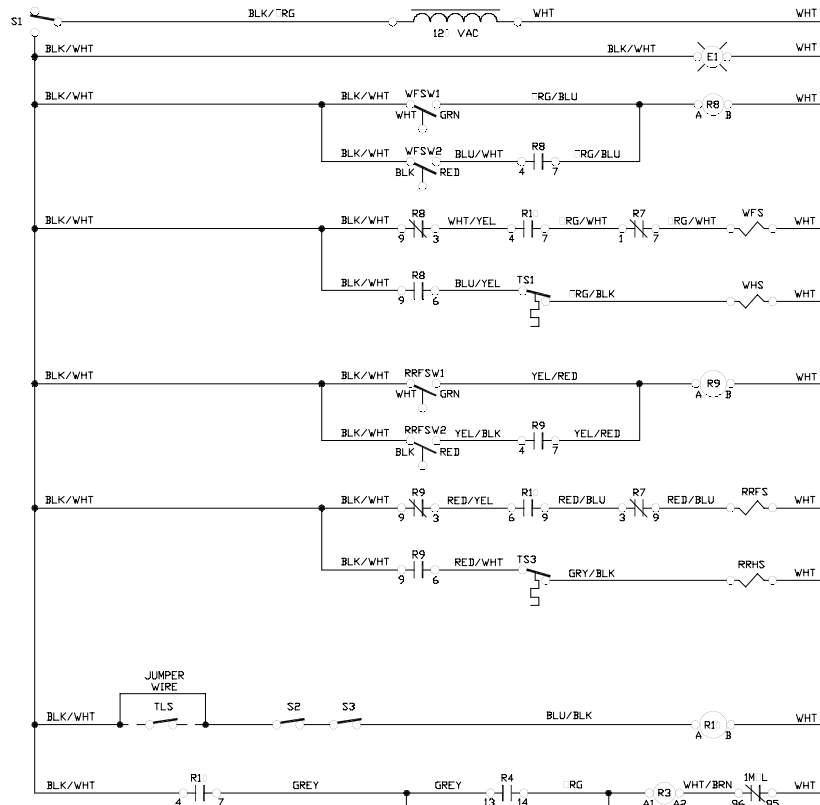

LEGEND

L1 L2 L3	POWER DISTRIBUTION BLACK
GND	GROUND
R3	DRIVE MOTOR CONTACTOR
R4	WASH PUMP MOTOR CONTACTOR
R5	R - RINSE PUMP MOTOR CONTACTOR
R6	FINAL RINSE RELAY #1
R7	FINAL RINSE RELAY #2
R8	WASH TANK FILL RELAY
R9	RECIRCULATING RINSE TANK FILL RELAY
R10	DOOR SAFETY SWITCH RELAY
M1	DRIVE MOTOR
M2	WASH PUMP MOTOR
M3	RECIRCULATING RINSE PUMP MOTOR
1M L	DRIVE MOTOR OVERLOAD
2M L	WASH PUMP MOTOR OVERLOAD
3M L	R - RINSE PUMP MOTOR OVERLOAD
FUSE	CENTRAL FUSE
T1	CENTRAL TRANSFORMER
DET	DETERGENT DISPENSER CONNECTION
CVS	CONSTANT VOLTAGE SIGNAL
S1	POWER SWITCH
S2	DOOR SAFETY SWITCH 1
S3	DOOR SAFETY SWITCH 2
S4	WASH PUMP SWITCH 1
S5	WASH PUMP SWITCH 2
S6	AUT - MAN/DELIME SWITCH
S7	RECIRCULATING RINSE PUMP SWITCH
S8	FINAL RINSE SWITCH
E1	POWER LIGHT
WHS	WASH HEAT SOLENOID
RRHS	RECIRCULATING RINSE HEAT SOLENOID
WFSW1	WASH FLAT SWITCH 1
WFSW2	WASH FLAT SWITCH 2
RRFSW1	RECIRCULATING RINSE FLAT SWITCH 1
RRFSW2	RECIRCULATING RINSE FLAT SWITCH 2
TS1	WASH REGULATING THERM STAT
TS3	R - RINSE REGULATING THERM STAT
CWTS	COLD WATER THERM STAT (PTIONAL)
CWV	COLD WATER VALVE (PTIONAL)
TLS	TABLE LIMIT SWITCH (PTIONAL)
WFS	WASH FILL SOLENOID
RRFS	RECIRCULATING RINSE FILL SOLENOID
RS	FINAL RINSE SOLENOID

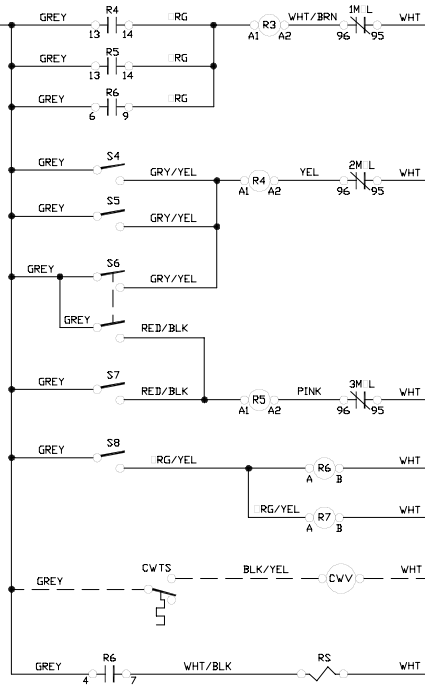

99-5-002-55-97A

SECTION 6: ELECTRICAL SCHEMATICS

AJ-86CE & AJ-100CE (208-230 VOLT, 60 HZ, SINGLE PHASE) SECONDARY SIDE

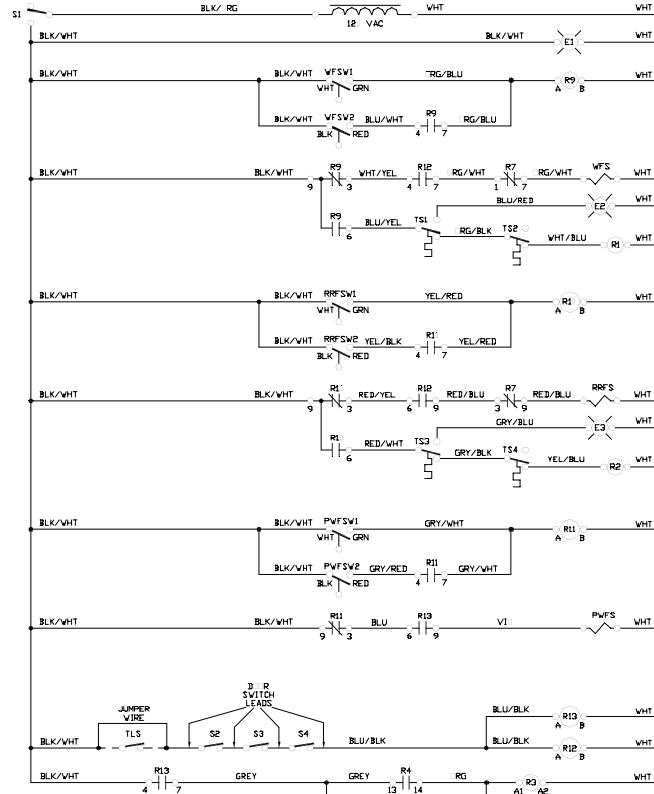

LEGEND

- | | |
|----------|---------------------------------------------|
| L1 L2 L3 | POWER DISTRIBUTION BLOCK |
| GR | GROUND |
| R1 | WASH TANK HEAT CONTACTOR |
| R2 | RECIRCULATING RINSE HEAT CONTACTOR |
| R3 | DRIVE MOTOR CONTACTOR |
| R4 | WASH PUMP MOTOR CONTACTOR |
| R5 | RECIRCULATING RINSE PUMP MOTOR CONTACTOR |
| R6 | FINAL RINSE RELAY #1 |
| R7 | FINAL RINSE RELAY #2 |
| R8 | PRE-WASH PUMP MOTOR CONTACTOR |
| R9 | WASH TANK FILL RELAY |
| R11 | RECIRCULATING RINSE TANK FILL RELAY |
| R11 | PRE-WASH TANK FILL RELAY |
| R12 | D/R SAFETY SWITCH RELAY #1 |
| R13 | D/R SAFETY SWITCH RELAY #2 |
| H1 | WASH HEATER |
| H2 | RECIRCULATING RINSE HEATER |
| M1 | DRIVE MOTOR |
| M2 | WASH PUMP MOTOR |
| M3 | RECIRCULATING RINSE PUMP MOTOR |
| M4 | PRE-WASH PUMP MOTOR |
| CB | CONTROL CIRCUIT BREAKER |
| T1 | CONTROL TRANSFORMER |
| DET | DETERGENT DISPENSER CONNECTION |
| CVS | CONSTANT VOLTAGE SIGNAL |
| S1 | POWER SWITCH |
| S2 | D/R SAFETY SWITCH 1 |
| S3 | D/R SAFETY SWITCH 2 |
| S4 | D/R SAFETY SWITCH 3 |
| S3 | WASH PUMP SWITCH 1 |
| S6 | WASH PUMP SWITCH 2 |
| S7 | AUT - MAN/DELIME SWITCH |
| S8 | RECIRCULATING RINSE PUMP SWITCH |
| S9 | FINAL RINSE SWITCH |
| S1 | PRE-WASH PUMP SWITCH |
| E1 | POWER LIGHT |
| E2 | WASH HEATER HIGH LIMIT LIGHT |
| E2 | RECIRCULATING RINSE HEATER HIGH LIMIT LIGHT |
| WFSV1 | WASH FLAT SWITCH 1 |
| WFSV2 | WASH FLAT SWITCH 2 |
| RRF5W1 | RECIRCULATING RINSE FLAT SWITCH 1 |
| RRF5W2 | RECIRCULATING RINSE FLAT SWITCH 2 |
| PWF5W1 | PRE-WASH FLAT SWITCH 1 |
| PWF5W2 | PRE-WASH FLAT SWITCH 2 |
| TS1 | HEATER HIGH LIMIT THERM STAT |
| TS2 | WASH REGULATING THERM STAT |
| TS1 | R - RINSE HEATER HIGH LIMIT THERM STAT |
| TS2 | R - RINSE REGULATING THERM STAT |
| CVTS | COLD WATER THERM STAT (PTI-NAL) |
| CVV | COLD WATER VALVE (PTI-NAL) |
| TLS | TABLE LIMIT SWITCH (PTI-NAL) |
| WFS | WASH FILL SLEN ID |
| RRFS | RECIRCULATING RINSE FILL SLEN ID |
| PWFS | PRE-WASH FILL SLEN ID |
| RS | FINAL RINSE SLEN ID |

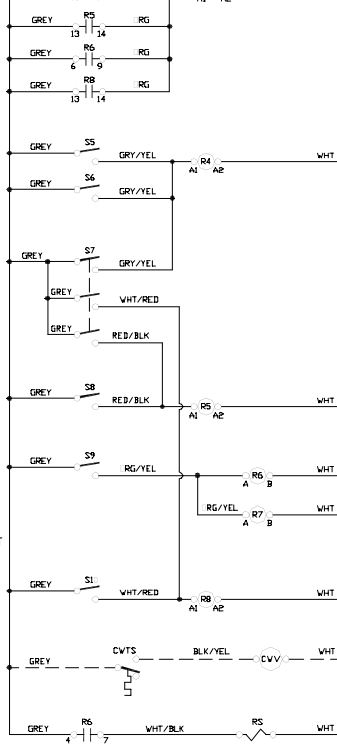

09905-031-80-35

SECTION 6: ELECTRICAL SCHEMATICS

AJ-86CE & AJ-100CE (208-230 VOLT, 60 HZ, THREE PHASE) PRIMARY SIDE

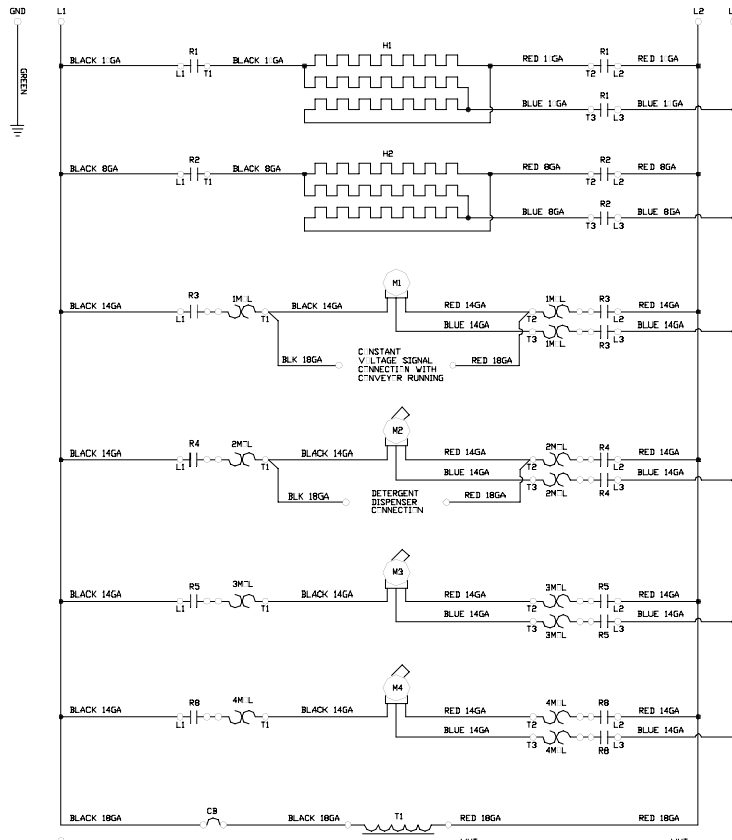

SECTION 6: ELECTRICAL SCHEMATICS

AJ-86CE & AJ-100CE (208-230 VOLT, 60 HZ, THREE PHASE) SECONDARY SIDE

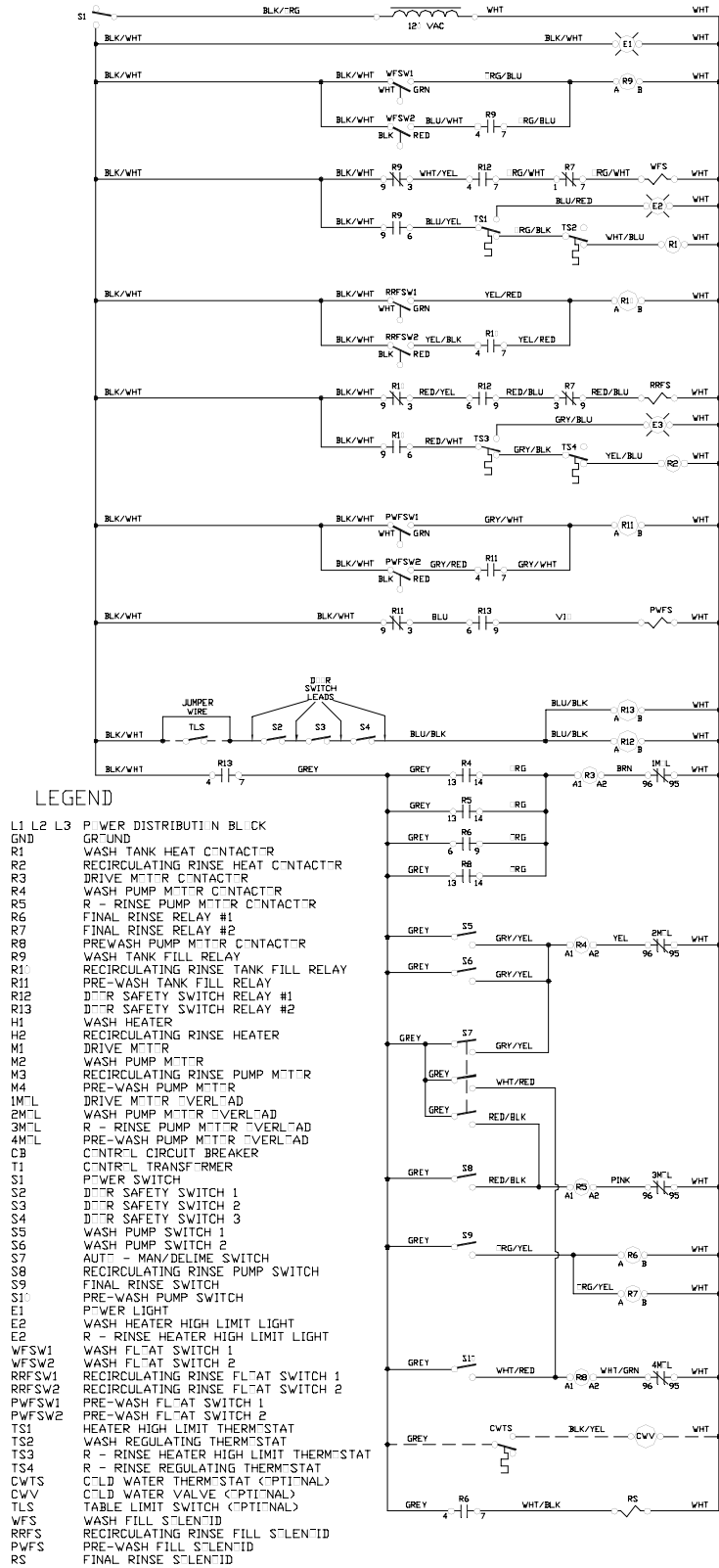

SECTION 6: ELECTRICAL SCHEMATICS

AJ-86CE & AJ-100CE (460 VOLT, 60 HZ, THREE PHASE) PRIMARY SIDE

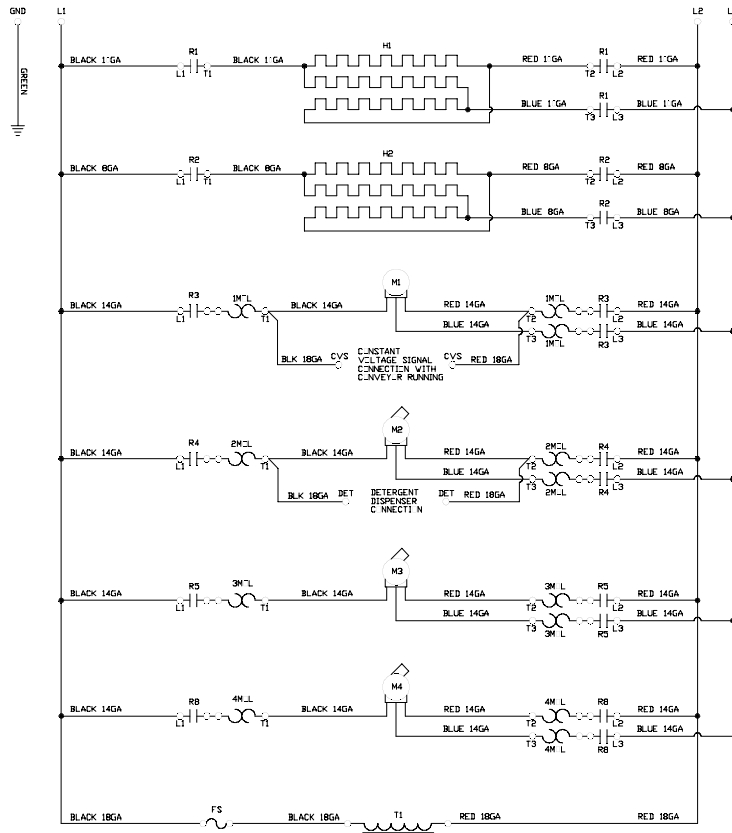

SECTION 6: ELECTRICAL SCHEMATICS

AJ-86CE & AJ-100CE (460 VOLT, 60 HZ, THREE PHASE) SECONDARY SIDE

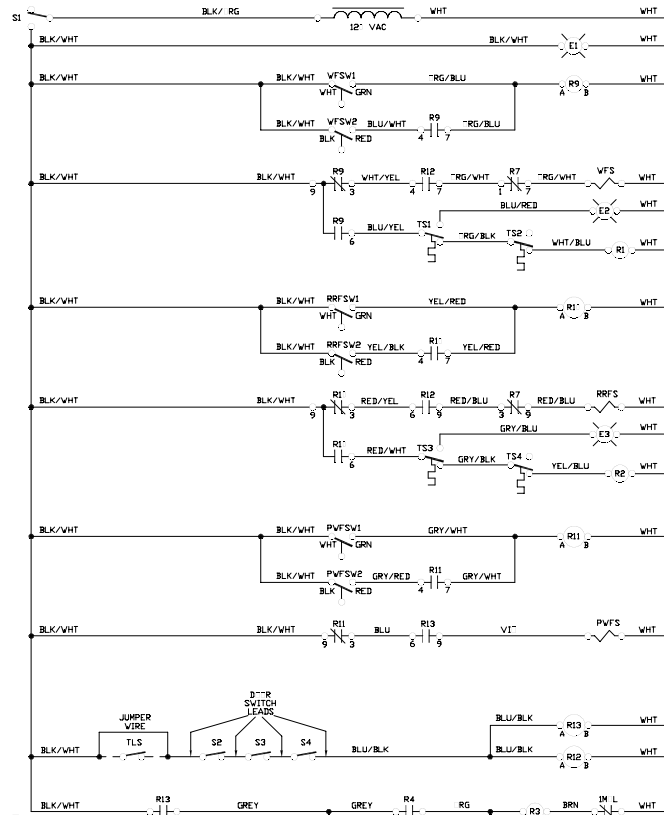

LEGEND

- L1 L2 L3 P-TWER DISTRIBUTION BLK/CK
- GND GR-UND
- R1 WASH TANK HEAT CONTACTOR
- R2 RECIRCULATING RINSE HEAT CONTACTOR
- R3 DRIVE MOTOR CONTACTOR
- R4 WASH PUMP MOTOR CONTACTOR
- R5 RECIRCULATING RINSE PUMP MOTOR CONTACTOR
- R6 FINAL RINSE RELAY #1
- R7 FINAL RINSE RELAY #2
- R8 PREWASH PUMP MOTOR CONTACTOR
- R9 WASH TANK FILL RELAY
- R10 RECIRCULATING RINSE TANK FILL RELAY
- R11 PRE-WASH TANK FILL RELAY
- R12 D-R SAFETY SWITCH RELAY #1
- R13 D-R SAFETY SWITCH RELAY #2
- H1 WASH HEATER
- H2 RECIRCULATING RINSE HEATER
- M1 DRIVE MOTOR
- M2 WASH PUMP MOTOR
- M3 RECIRCULATING RINSE PUMP MOTOR
- M4 PRE-WASH PUMP MOTOR
- 1M L DRIVE MOTOR VERL AD
- 2M L WASH PUMP MOTOR VERL AD
- 3M L RECIRCULATING RINSE PUMP MOTOR VERL AD
- 4M L PRE-WASH PUMP MOTOR VERL AD
- FS C NTR L FUSE
- T1 C NTR L TRANSFORMER
- DET DETERGENT DISPENSER CONNECTION
- CVS P WER SWITCH
- S1 D-R SAFETY SWITCH 1
- S2 D-R SAFETY SWITCH 2
- S3 D-R SAFETY SWITCH 3
- S4 WASH PUMP SWITCH 1
- S5 WASH PUMP SWITCH 2
- S6 AUT - MAN/DELTIME SWITCH
- S7 RECIRCULATING RINSE PUMP SWITCH
- S8 FINAL RINSE SWITCH
- S9 PRE-WASH PUMP SWITCH
- E1 P WER LIGHT
- E2 WASH HEATER HIGH LIMIT LIGHT
- WFSW1 WASH FL AT SWITCH 1
- WFSW2 WASH FL AT SWITCH 2
- RRFSW1 RECIRCULATING RINSE FL AT SWITCH 1
- RRFSW2 RECIRCULATING RINSE FL AT SWITCH 2
- PWFSW1 PRE-WASH FL AT SWITCH 1
- PWFSW2 PRE-WASH FL AT SWITCH 2
- TS1 HEATER HIGH LIMIT THERM STAT
- TS2 WASH REGULATING THERM STAT
- TS1 R - RINSE HEATER HIGH LIMIT THERM STAT
- TS2 R - RINSE REGULATING THERM STAT
- CVTS C LD WATER THERM STAT (PTI NAL)
- CVV C LD WATER VALVE (PTI NAL)
- TLS TABLE LIMIT SWITCH (PTI NAL)
- WFS WASH FILL S LEN ID
- RRFS RECIRCULATING RINSE FILL S LEN ID
- PWFS PRE-WASH FILL S LEN ID
- RS FINAL RINSE S LEN ID

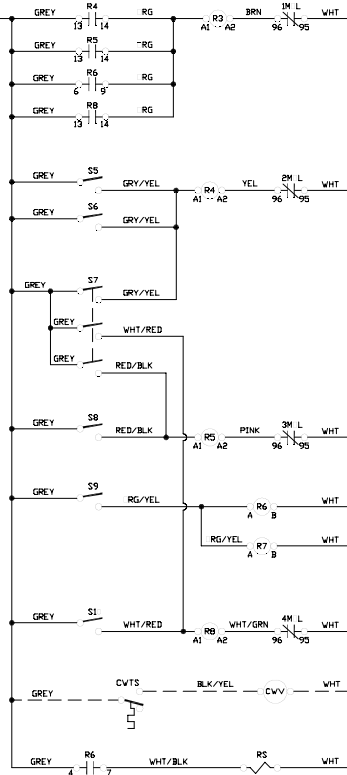

99 5- 41-94-99

SECTION 6: ELECTRICAL SCHEMATICS

AJ-86CS & AJ-100CS (208-230 VOLT, 60 HZ, SINGLE PHASE) PRIMARY SIDE

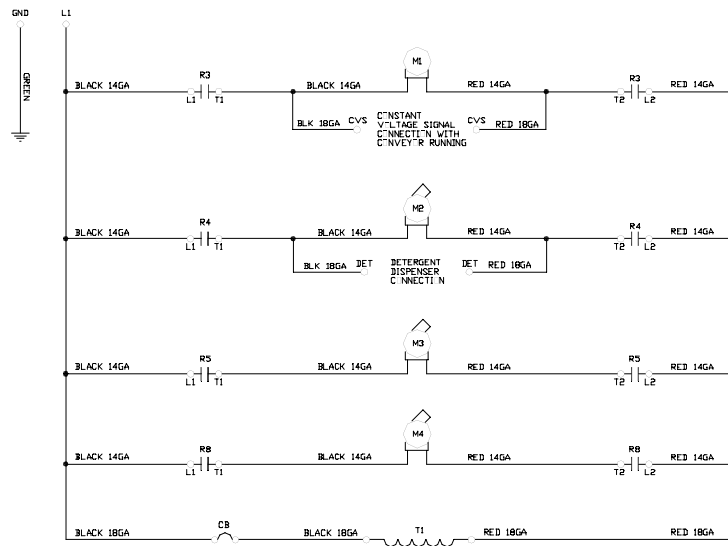

SECTION 6: ELECTRICAL SCHEMATICS

AJ-86CS & AJ-100CS (208-230 VOLT, 60 HZ, SINGLE PHASE) SECONDARY SIDE

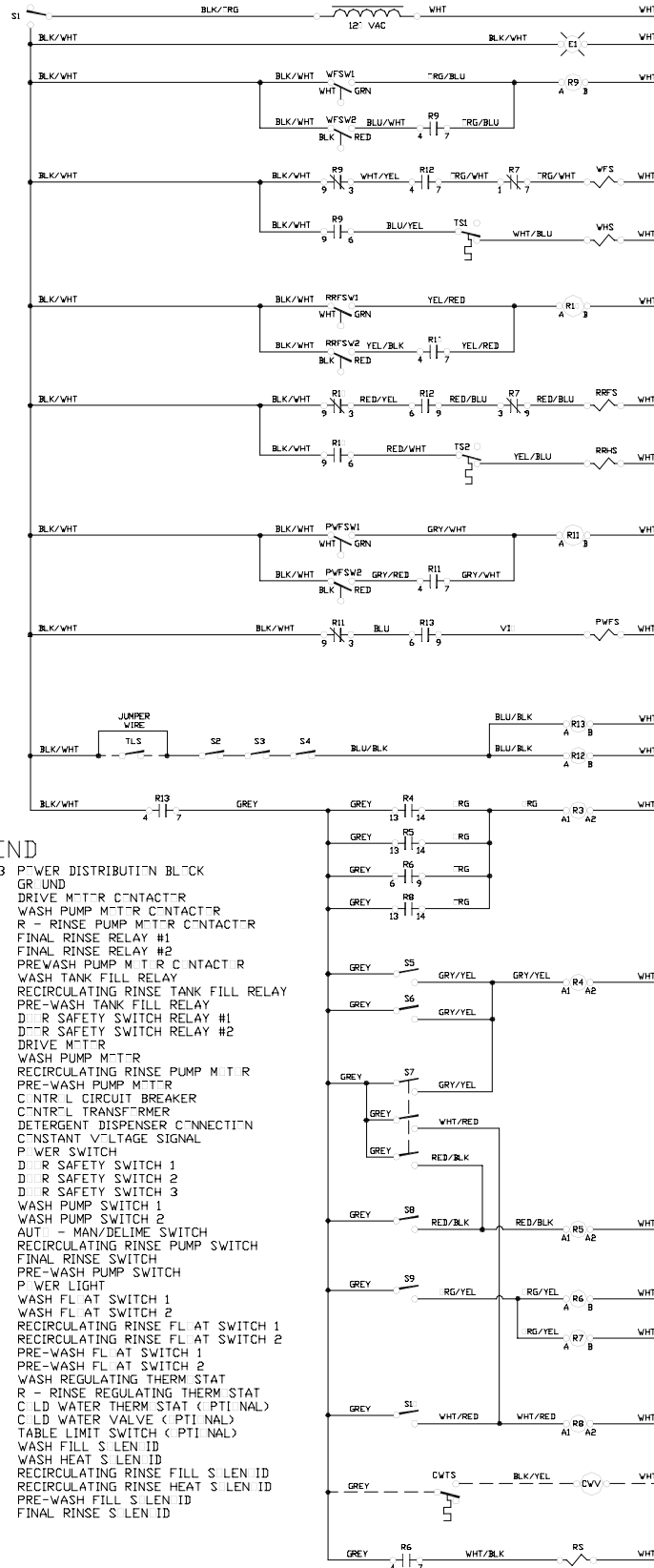

- LEGEND**
- L1 L2 L3 POWER DISTRIBUTION BLOCK
 - GND GR. UND
 - R3 DRIVE MOTOR CONTACTOR
 - R4 WASH PUMP MOTOR CONTACTOR
 - R5 R - RINSE PUMP MOTOR CONTACTOR
 - R6 FINAL RINSE RELAY #1
 - R7 FINAL RINSE RELAY #2
 - R8 PREWASH PUMP MOTOR CONTACTOR
 - R9 WASH TANK FILL RELAY
 - R10 RECIRCULATING RINSE TANK FILL RELAY
 - R11 PRE-WASH TANK FILL RELAY
 - R12 DRR SAFETY SWITCH RELAY #1
 - R13 DRR SAFETY SWITCH RELAY #2
 - M1 DRIVE MOTOR
 - M2 WASH PUMP MOTOR
 - M3 RECIRCULATING RINSE PUMP MOTOR
 - M4 PRE-WASH PUMP MOTOR
 - CB C.N.T.R.L. CIRCUIT BREAKER
 - T1 C.N.T.R.L. TRANSFORMER
 - DET DETERGENT DISPENSER CONNECTION
 - CVS CONSTANT VOLTAGE SIGNAL
 - S1 POWER SWITCH
 - S2 DRR SAFETY SWITCH 1
 - S3 DRR SAFETY SWITCH 2
 - S4 DRR SAFETY SWITCH 3
 - S5 WASH PUMP SWITCH 1
 - S6 WASH PUMP SWITCH 2
 - S7 AUTO - MAN/DELIME SWITCH
 - S8 RECIRCULATING RINSE PUMP SWITCH
 - S9 FINAL RINSE SWITCH
 - S10 PRE-WASH PUMP SWITCH
 - E1 POWER LIGHT
 - WFSW1 WASH FL. AT SWITCH 1
 - WFSW2 WASH FL. AT SWITCH 2
 - RRFSW1 RECIRCULATING RINSE FL. AT SWITCH 1
 - RRFSW2 RECIRCULATING RINSE FL. AT SWITCH 2
 - PWFSW1 PRE-WASH FL. AT SWITCH 1
 - PWFSW2 PRE-WASH FL. AT SWITCH 2
 - TS1 WASH REGULATING THERM. STAT
 - TS2 R - RINSE REGULATING THERM. STAT
 - CVTS C.L.D. WATER THERM. STAT (PTI. NAL)
 - CWV C.L.D. WATER VALVE (PTI. NAL)
 - TLS TABLE LIMIT SWITCH (PTI. NAL)
 - WFS WASH FILL S. LEN. ID
 - WHS WASH HEAT S. LEN. ID
 - RRFS RECIRCULATING RINSE FILL S. LEN. ID
 - RRHS RECIRCULATING RINSE HEAT S. LEN. ID
 - PWFS PRE-WASH FILL S. LEN. ID
 - RS FINAL RINSE S. LEN. ID

99-5-002-56-3

SECTION 6: ELECTRICAL SCHEMATICS

AJ-86CS & AJ-100CS (208-230 VOLT, 60 HZ, THREE PHASE) PRIMARY SIDE

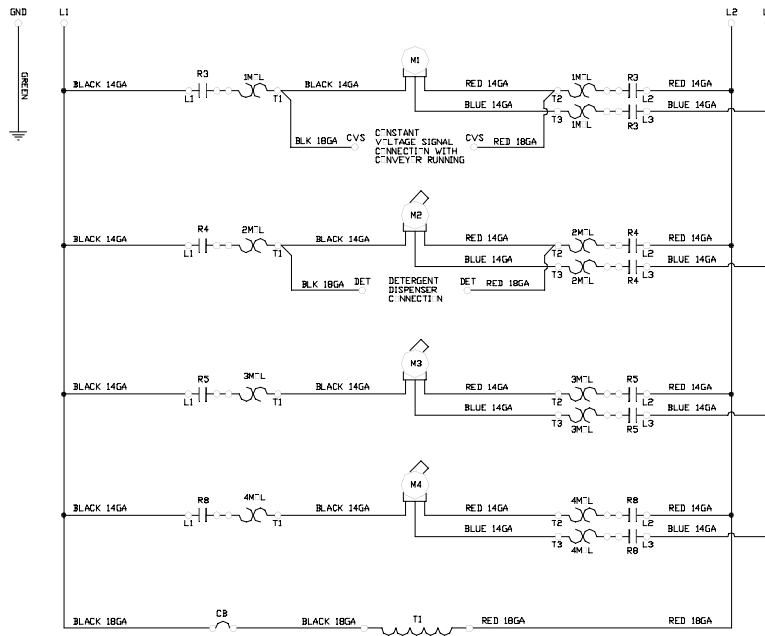

SECTION 6: ELECTRICAL SCHEMATICS

AJ-86CS & AJ-100CS (208-230 VOLT, 60 HZ, THREE PHASE) SECONDARY SIDE

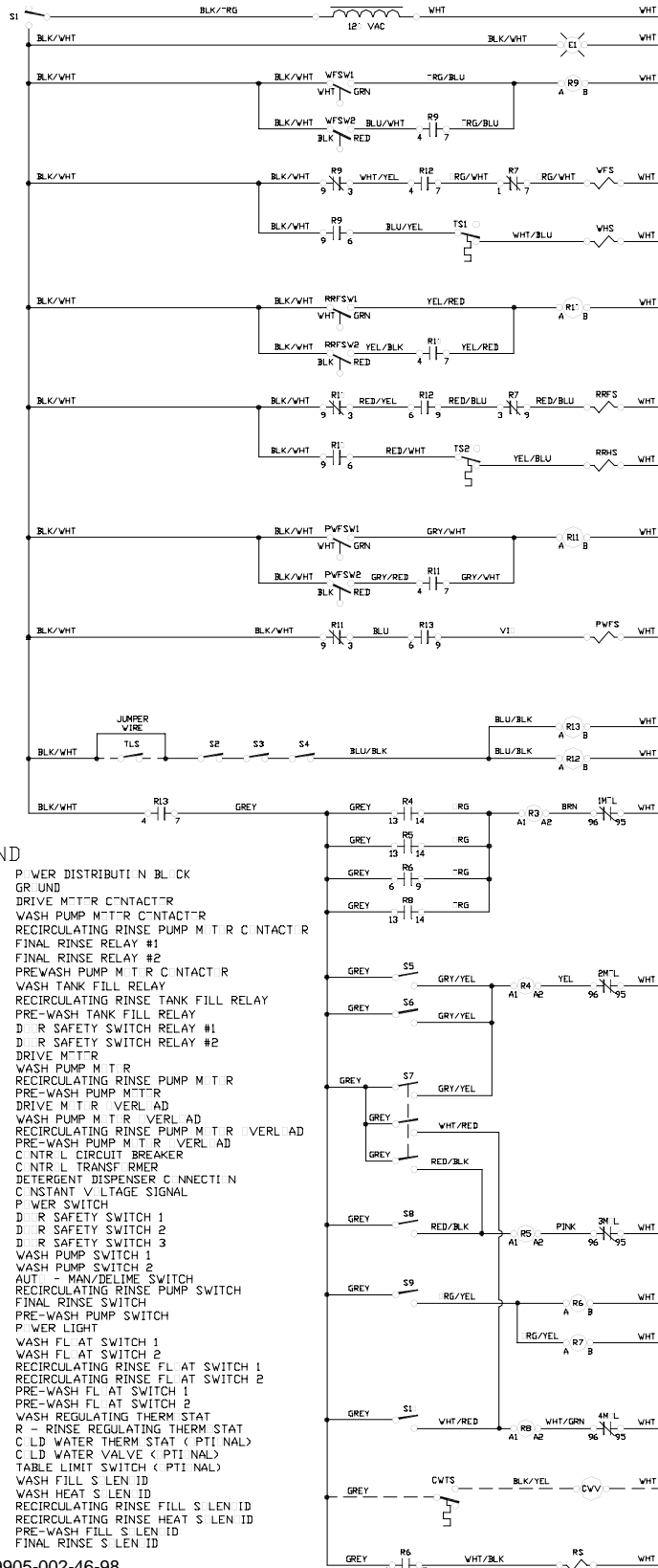

LEGEND

- L1 L2 L3 POWER DISTRIBUTION BLOCK
- GND GROUND
- R3 DRIVE MOTOR CONTACTOR
- R4 WASH PUMP MOTOR CONTACTOR
- R5 RECIRCULATING RINSE PUMP MOTOR CONTACTOR
- R6 FINAL RINSE RELAY #1
- R7 FINAL RINSE RELAY #2
- R8 PRE-WASH PUMP MOTOR CONTACTOR
- R9 WASH TANK FILL RELAY
- R1 RECIRCULATING RINSE TANK FILL RELAY
- R11 PRE-WASH TANK FILL RELAY
- R12 DRIVER SAFETY SWITCH RELAY #1
- R13 DRIVER SAFETY SWITCH RELAY #2
- M1 DRIVE MOTOR
- M2 WASH PUMP MOTOR
- M3 RECIRCULATING RINSE PUMP MOTOR
- M4 PRE-WASH PUMP MOTOR
- 1M L DRIVE MOTOR OVERLOAD
- 2M L WASH PUMP MOTOR OVERLOAD
- 3M L RECIRCULATING RINSE PUMP MOTOR OVERLOAD
- 4M L PRE-WASH PUMP MOTOR OVERLOAD
- CB CENTRAL CIRCUIT BREAKER
- TI THERMAL INTERRUPTER
- DET DETERGENT DISPENSER CONNECTION
- CVS CONSTANT VOLTAGE SIGNAL
- S1 POWER SWITCH
- S2 DRIVER SAFETY SWITCH 1
- S3 DRIVER SAFETY SWITCH 2
- S4 DRIVER SAFETY SWITCH 3
- S5 WASH PUMP SWITCH 1
- S6 WASH PUMP SWITCH 2
- S7 AUTOMAN/DELIMIT SWITCH
- S8 RECIRCULATING RINSE PUMP SWITCH
- S9 FINAL RINSE SWITCH
- S1 PRE-WASH PUMP SWITCH
- E1 POWER LIGHT
- WFSW1 WASH FLAT SWITCH 1
- WFSW2 WASH FLAT SWITCH 2
- RRFSW1 RECIRCULATING RINSE FLAT SWITCH 1
- RRFSW2 RECIRCULATING RINSE FLAT SWITCH 2
- PWFSW1 PRE-WASH FLAT SWITCH 1
- PWFSW2 PRE-WASH FLAT SWITCH 2
- SR RINSE REGULATING THERMISTAT
- CWTS COLD WATER THERMISTAT (PTINALE)
- CVV COLD WATER VALVE (PTINALE)
- TLT TABLE LIMIT SWITCH (PTINALE)
- WFS WASH FILL SIGNAL ID
- WHS WASH HEAT SIGNAL ID
- RRFS RECIRCULATING RINSE FILL SIGNAL ID
- RRHS RECIRCULATING RINSE HEAT SIGNAL ID
- PWFS PRE-WASH FILL SIGNAL ID
- RS FINAL RINSE SIGNAL ID

09905-002-46-98

SECTION 6: ELECTRICAL SCHEMATICS

AJ-86CS & AJ-100CS (460 VOLT, 60 HZ, THREE PHASE) PRIMARY SIDE

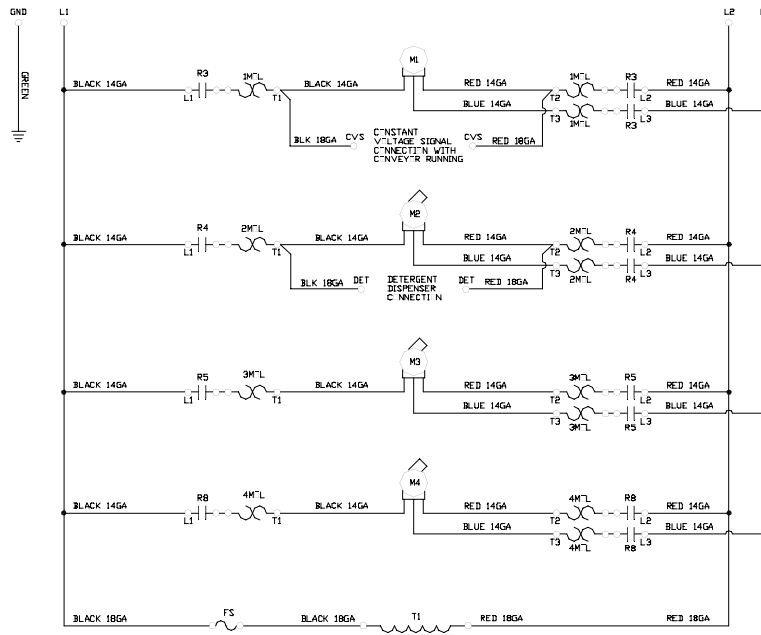

SECTION 6: ELECTRICAL SCHEMATICS

AJ-86CS & AJ-100CS (460 VOLT, 60 HZ, THREE PHASE) SECONDARY SIDE

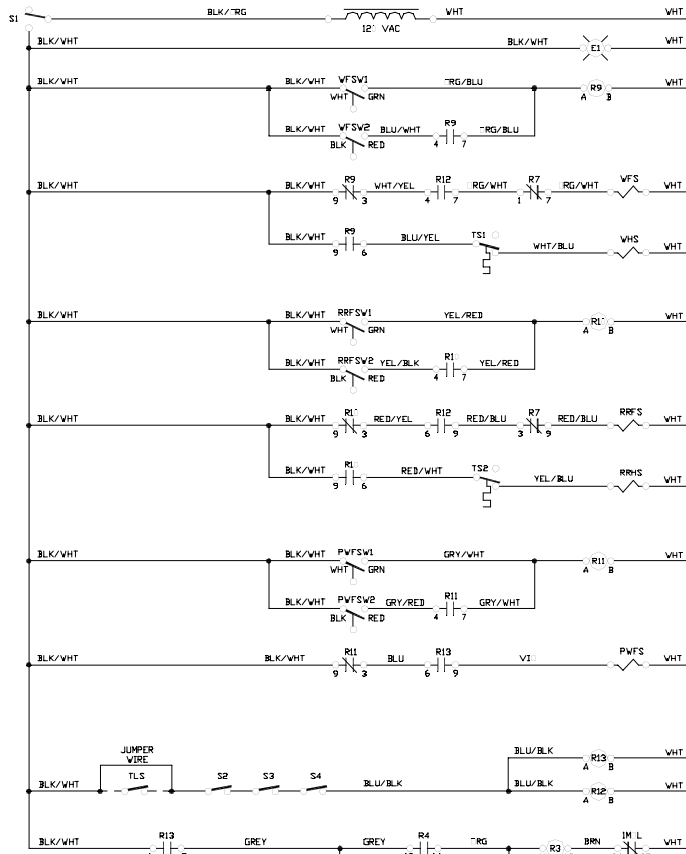

LEGEND

- L1 L2 L3 POWER DISTRIBUTION BLOCK
- GND GROUND
- R3 DRIVE MOTOR CONTACTOR
- R4 WASH PUMP MOTOR CONTACTOR
- R5 R - RINSE PUMP MOTOR CONTACTOR
- R6 FINAL RINSE RELAY #1
- R7 FINAL RINSE RELAY #2
- R8 PREWASH PUMP MOTOR CONTACTOR
- R9 WASH TANK FILL RELAY
- R1 RECIRCULATING RINSE TANK FILL RELAY
- R11 PRE-WASH TANK FILL RELAY
- R12 DETERGENT SAFETY SWITCH RELAY #1
- R13 DETERGENT SAFETY SWITCH RELAY #2
- M1 DRIVE MOTOR
- M2 WASH PUMP MOTOR
- M3 RECIRCULATING RINSE PUMP MOTOR
- M4 PRE-WASH PUMP MOTOR
- 1M^L DRIVE MOTOR OVERLOAD
- 2M^L WASH PUMP MOTOR OVERLOAD
- 3M^L R - RINSE PUMP MOTOR OVERLOAD
- 4M^L PRE-WASH PUMP MOTOR OVERLOAD
- FS CONTROL FUSE
- T1 CONTROL TRANSFORMER
- DET DETERGENT DISPENSER CONNECTION
- CVS CONSTANT VOLTAGE SIGNAL
- S1 POWER SWITCH
- S2 DETERGENT SAFETY SWITCH 1
- S3 DETERGENT SAFETY SWITCH 2
- S4 DETERGENT SAFETY SWITCH 3
- S5 WASH PUMP SWITCH 1
- S6 WASH PUMP SWITCH 2
- S7 AUTO - MAN/DELIMIT SWITCH
- S8 RECIRCULATING RINSE PUMP SWITCH
- S9 FINAL RINSE SWITCH
- S1 PRE-WASH PUMP SWITCH
- E1 POWER LIGHT
- WFSW1 WASH FLAT SWITCH 1
- WFSW2 WASH FLAT SWITCH 2
- RRFSW1 RECIRCULATING RINSE FLAT SWITCH 1
- RRFSW2 RECIRCULATING RINSE FLAT SWITCH 2
- PWFSW1 PRE-WASH FLAT SWITCH 1
- PWFSW2 PRE-WASH FLAT SWITCH 2
- TS1 WASH REGULATING THERMISTAT
- TS2 R - RINSE REGULATING THERMISTAT
- CWTS COLD WATER THERMISTAT (PTI)NAL
- CWV COLD WATER VALVE (PTI)NAL
- TLS TABLE LIMIT SWITCH (PTI)NAL
- VFS WASH FILL SIGNAL ID
- VHS WASH HEAT SIGNAL ID
- RRFS RECIRCULATING RINSE FILL SIGNAL ID
- RRHS RECIRCULATING RINSE HEAT SIGNAL ID
- PWFS PRE-WASH FILL SIGNAL ID
- RS FINAL RINSE SIGNAL ID

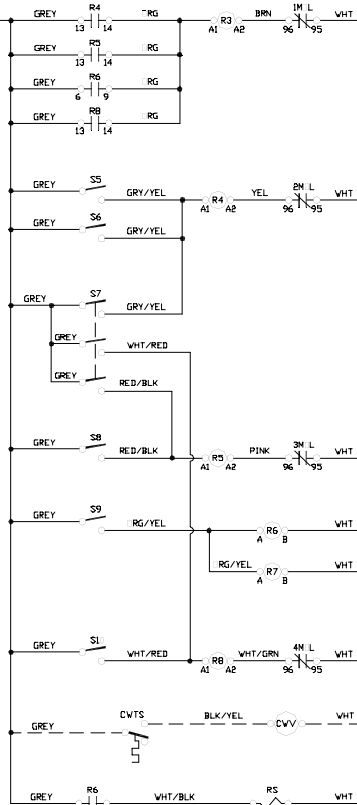

99-5-41-93-74

SECTION 6: ELECTRICAL SCHEMATICS

AJ-86CGP & AJ-100CGP (208-230 VOLTS, 60 HZ, SINGLE PHASE) PRIMARY SIDE

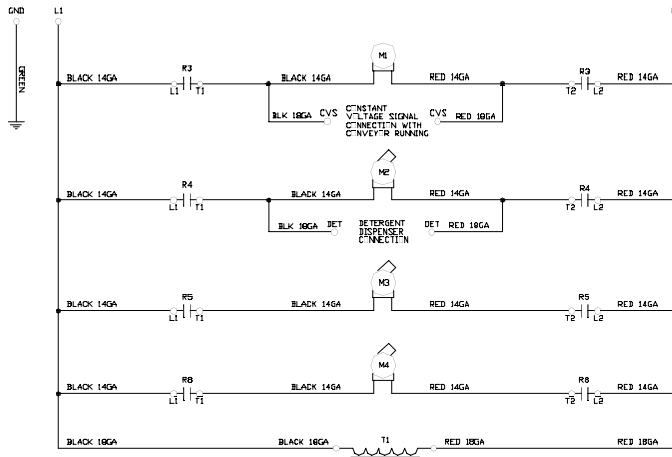

SECTION 6: ELECTRICAL SCHEMATICS

AJ-86CGP & AJ-100CGP (208-230 VOLTS, 60 HZ, SINGLE PHASE) SECONDARY SIDE

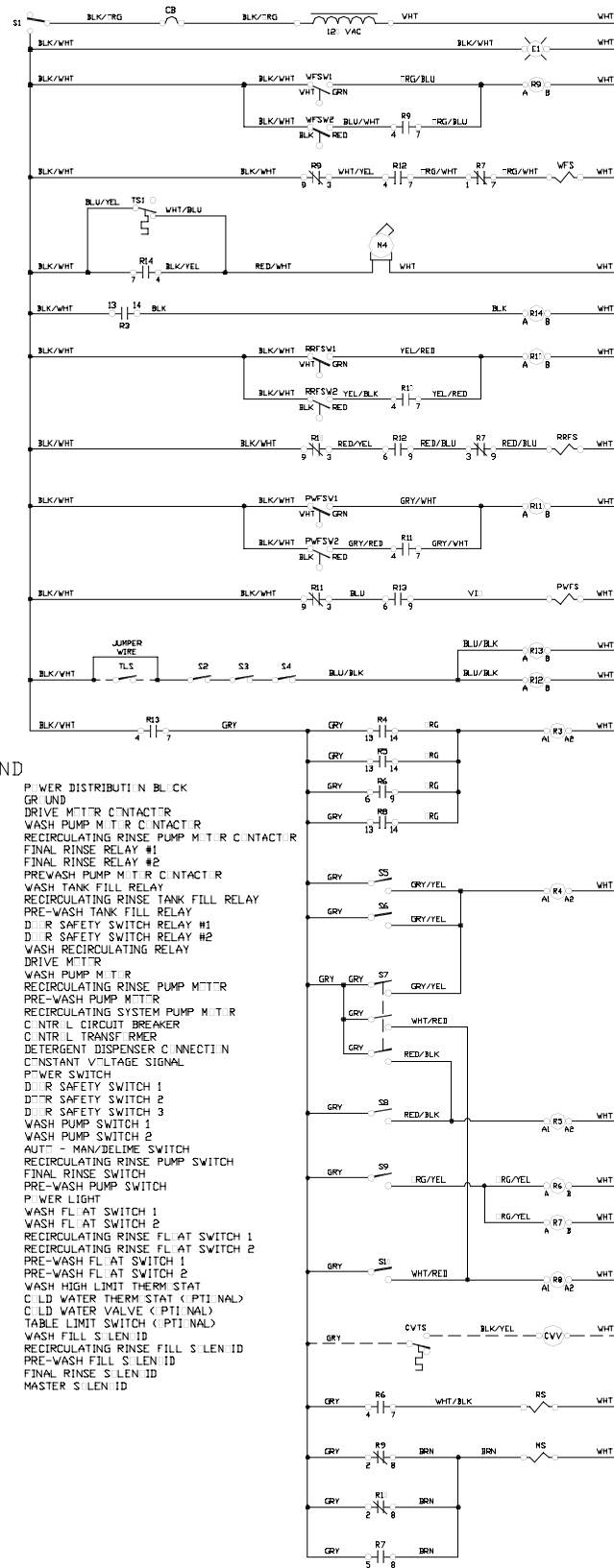

99 5--2-6--59.

SECTION 6: ELECTRICAL SCHEMATICS

AJ-86CGP & AJ-100CGP (208-230 VOLTS, 60 HZ, THREE PHASE) PRIMARY SIDE

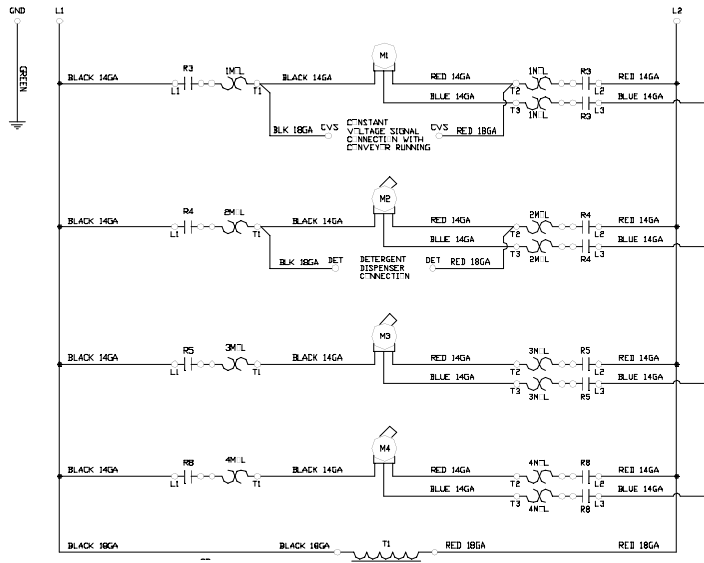

SECTION 6: ELECTRICAL SCHEMATICS

AJ-86CGP & AJ-100CGP (208-230 VOLTS, 60 HZ, THREE PHASE) SECONDARY SIDE

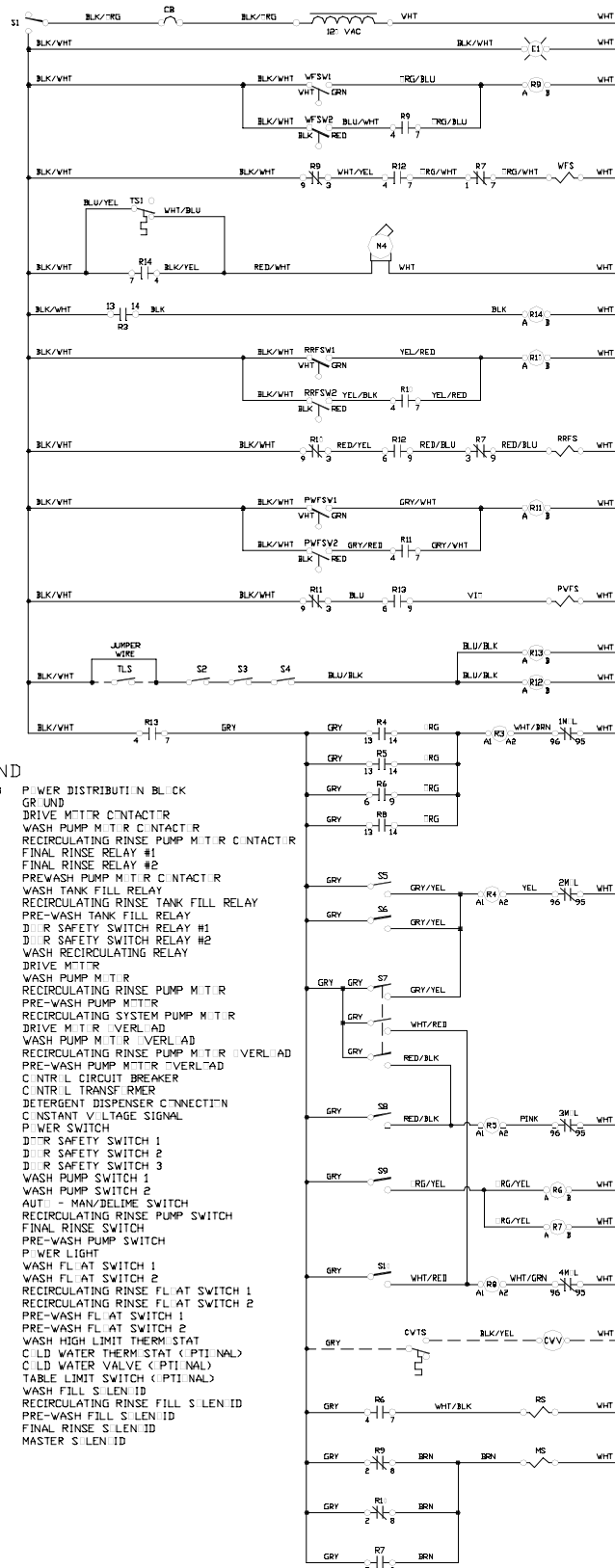

9915-41-06-74c

SECTION 6: ELECTRICAL SCHEMATICS

AJ-86CGP & AJ-100CGP (460 VOLTS, 60 HZ, THREE PHASE) PRIMARY SIDE

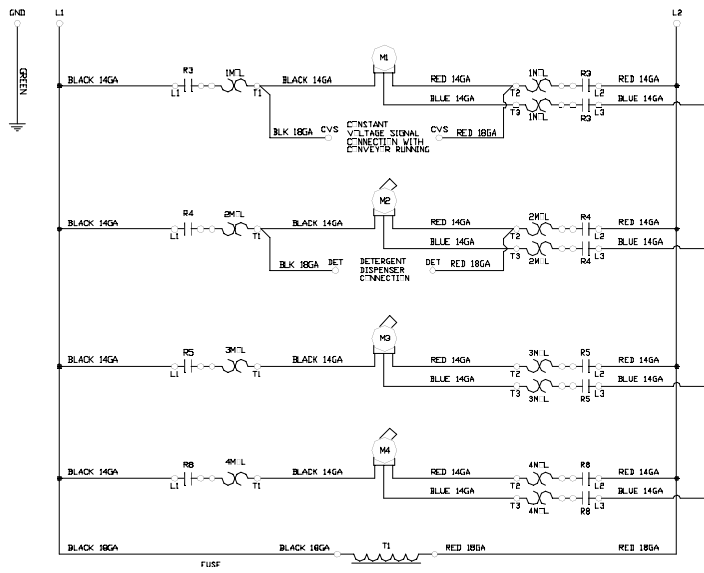

SECTION 6: ELECTRICAL SCHEMATICS

AJ-86CGP & AJ-100CGP (460 VOLTS, 60 HZ, THREE PHASE) SECONDARY SIDE

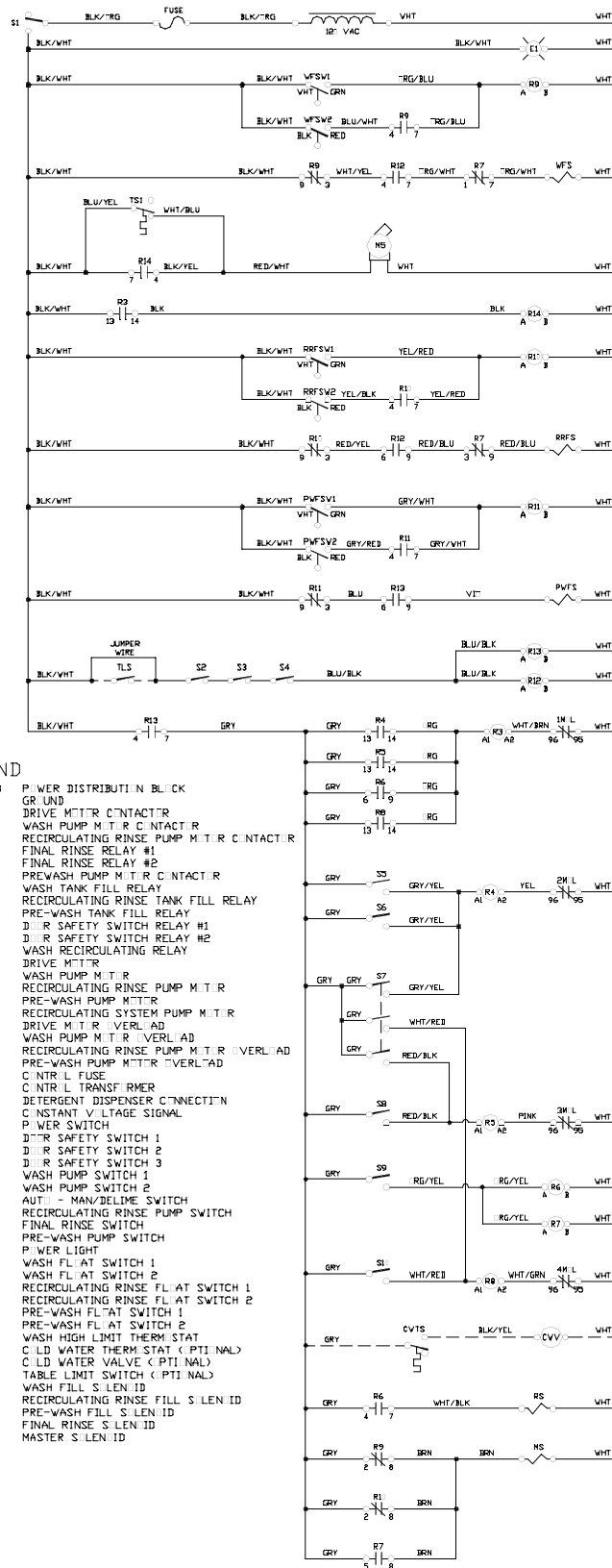

9915-112-61-52

SECTION 6: ELECTRICAL SCHEMATICS
CONVEYOR EXHAUST FAN HOOKUP

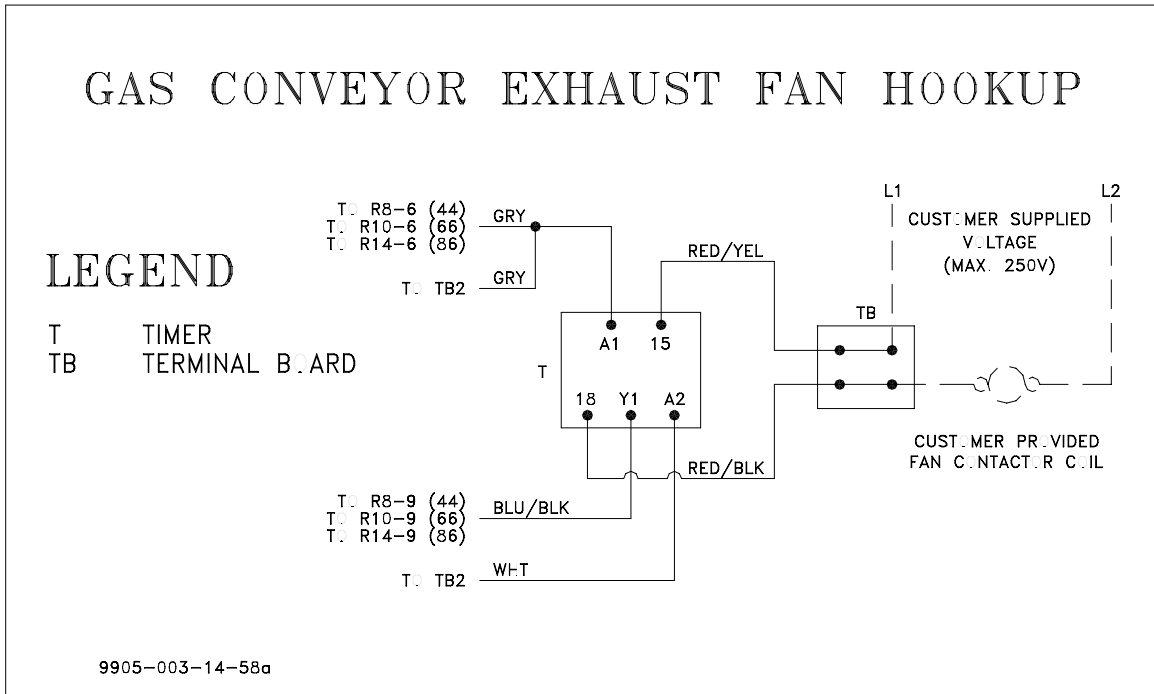
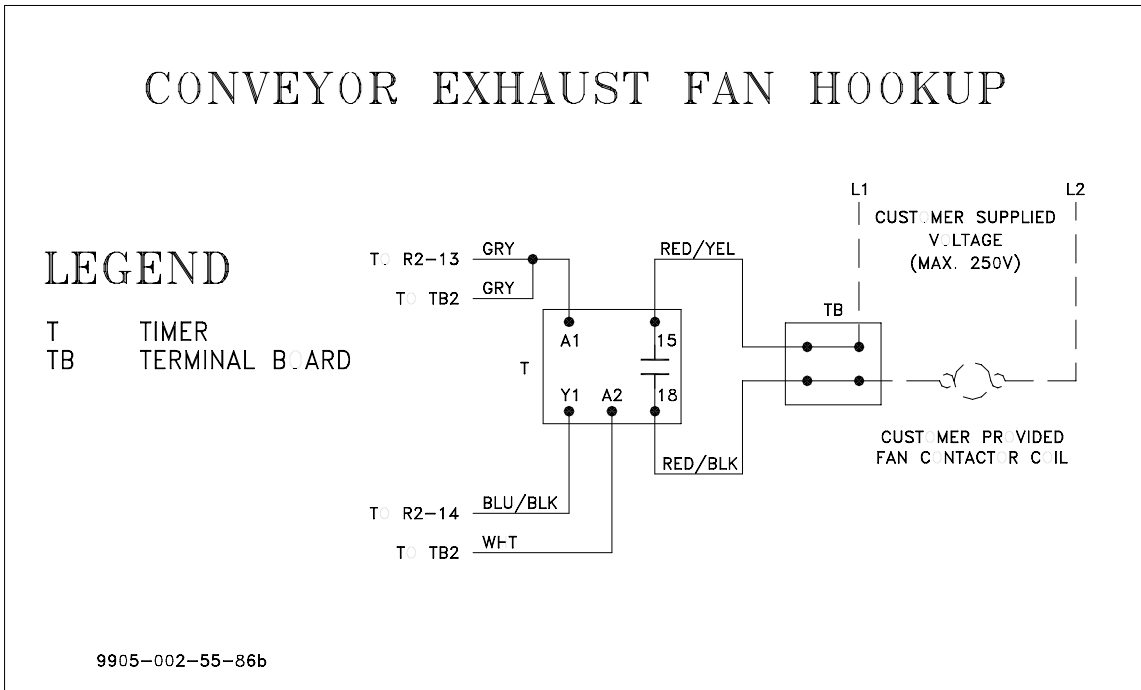

SECTION 6: ELECTRICAL SCHEMATICS

D226 STEAM BOOSTER/DRAIN QUENCH SYSTEM/SIDE LOADER

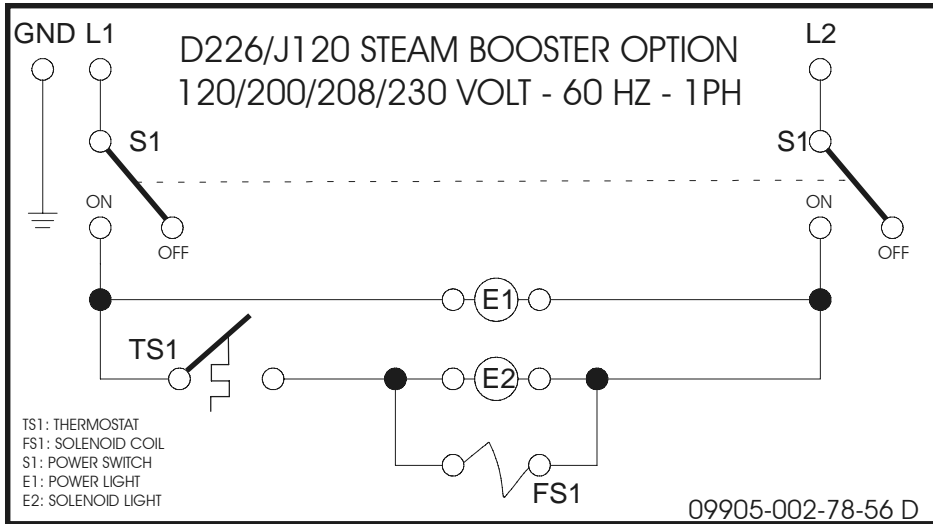

Drain Quench System

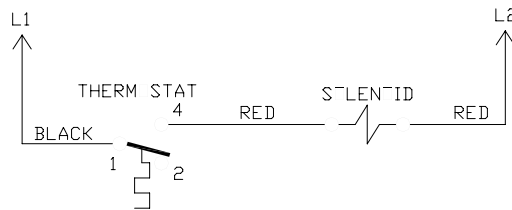

CONNECT BLACK WIRE TO THERM CONTACTOR - L1 WITH PIGGYBACK TERMINAL PROVIDED
CONNECT WHITE WIRE TO THERM CONTACTOR - L2 WITH PIGGYBACK TERMINAL PROVIDED

CONVEYOR SIDE LOADER

64" CONVEYORS

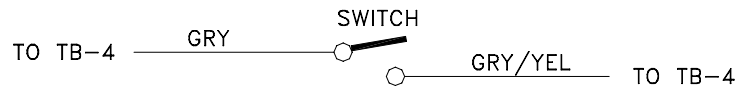

86" & 100" CONVEYORS

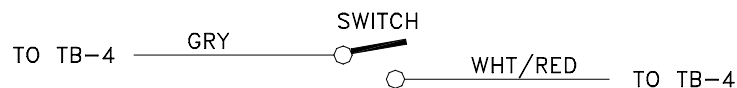

9905-002-56-84a

**SECTION 7:
JACKSON MAINTENANCE
& REPAIR CENTERS**

SECTION 7: JACKSON MAINTENANCE & REPAIR CENTERS

ALABAMA TO FLORIDA

ALABAMA

JONES-McLEOD APPLIANCE SVC

1616 7TH AVE. NORTH
BIRMINGHAM, AL 35203
(205) 251-0159
800-821-1150
FAX: (205) 322-1440
service@jones-mcleod.com

JONES-McLEOD APPLIANCE SVC

854 LAKESIDE DRIVE
MOBILE, AL 36693
(251) 666-7278
800-237-9859
FAX: (251) 661-0223

ALASKA

RESTAURANT APPLIANCE SERVICE

7219 ROOSEVELT WAY NE
SEATTLE, WA 98115
(206) 524-8200
800-433-9390
FAX: (206) 525-2890
info@restappl.com

ARIZONA

AUTHORIZED COMMERCIAL FOOD EQMT. SVC

4832 SOUTH 35TH STREET
PHOENIX, AZ 85040
(602) 234-2443
800-824-8875
FAX: (602) 232-5862
acsboss@aol.com

GCS SERVICE INC.

PHOENIX, AZ
(602) 474-4510
800-510-3497
FAX: (602) 470-4511

ARKANSAS

BROMLEY PARTS & SVC

10TH AND RINGO
P.O. BOX 1688
LITTLE ROCK, AR 72202
(501) 374-0281
800-482-9269
FAX: (501) 374-8352
service@bromleyparts.com
parts@bromleyparts.com

GCS SERVICE, INC.

3717 CHERRY ROAD
MEMPHIS, TN 38118
(901) 366-4587
800-262-9155
FAX: (901) 366-4588

CALIFORNIA

BARKERS FOOD MACHINERY SERVICES

5367 SECOND STREET
IRWINDALE, CA 91706
(626) 960-9390
800-258-6999
FAX: (626) 337-4541
service@barkers.com

GCS SERVICE INC.

LOS ANGELES, CA
(213) 683-2090
800-327-1433
FAX: (213) 683-2099

GCS SERVICE INC.

SANTA ANA, CA
(714) 542-1798
800-540-0719
FAX: (714) 542-4787

GCS SERVICE INC.

S. SAN FRANCISCO, CA
(650) 635-0720
800-969-4427
FAX: (650) 871-4019

COMMERCIAL APPLIANCE SERVICE, INC.

6507 PACIFIC AVENUE, SUITE 102
STOCKTON, CA 95207
(916) 567-0203
(800) 464-2222
(916) 567-0266 FAX

GCS SERVICE INC.

SAN DIEGO, CA
(858) 549-8411
800-422-7278
FAX: (858) 549-2323

INDUSTRIAL ELECTRIC SVC.

5662 ENGINEER DRIVE
HUNTINGTON BEACH, CA 92649
(714) 379-7100
(800-457-3783
FAX: (714) 379-7109

P & D APPLIANCE SVC

100 SOUTH LINDEN AVE.
S. SAN FRANCISCO, CA 94080
(650) 635-1900
800-424-1414
FAX: (650) 635-1919
pndappl@aol.com

P & D APPLIANCE

4220-C ROSEVILLE ROAD
NORTH HIGHLANDS, CA 95660
(916) 974-2772
800-824-7219
FAX: (916) 974-2774

COMMERCIAL APPLIANCE SERVICE, INC.

281 LATHROP WAY, #100
SACRAMENTO, CA 95815
(916) 567-0203
(800) 464-2222
(916) 567-0324 FAX

COLORADO

GCS SERVICE INC.

SHERIDAN, CO
(303) 371-9054
800-972-5314
FAX: (303) 371-4754

HAWKINS COMMERCIAL APPLIANCE SERVICE

3000 S. WYANDOT ST.
ENGLEWOOD, CO 80110
(303) 781-5548
(800) 624-2117
FAX: (303) 761-5561
johns@hawkinscommercial.com

METRO APPLIANCE SERVICE

1640 S BROADWAY
DENVER, CO 80210
(303) 778-1126
800-525-3532
FAX: (303) 778-0268
metroappls@aol.com

CONNECTICUT

GCS SERVICE INC.

HARTFORD, CT
(860) 549-5575
800-423-1562
FAX: (860) 527-6355

SUPERIOR KITCHEN SERVICE INC.

22 THOMPSON ROAD
WINDSOR, CT 06088
(888) 590-1899
(888) 590-1996 FAX

DELAWARE

FOOD SERVICE EQMT.

2101 PARKWAY SOUTH
BROOMALL, PA 19008
(610) 356-6900
FAX: (610) 356-2038
dancerule@aol.com

GCS SERVICE INC.

PHILADELPHIA, PA
(215)925-6217
800-441-9115
FAX: (215) 925-6208

ELMER SCHULTZ SERVICE

36 BELMONT AVE.
WILLMINGTON, DE 19804
(302) 655-8900
800-225-0599
FAX: (302) 656-3673
elmer2@erols.com

EMR SERVICE DIVISION

106 WILLIAMSPORT CIRCLE
SALISBURY, MD 21804
(410) 543-8197
FAX: (410) 548-4038

FLORIDA

COMMERCIAL APPLIANCE SERVICE

8416 LAUREL FAIR CIRCLE
BLDG 6, SUITE 114
TAMPA, FL 33610
(813) 663-0313
800-282-4718
FAX: (813) 663-0212
commercialappliance@world-net.att.net

GCS SERVICE INC

MIAMI, FL
(305) 621-6666
800-766-8966
FAX: (305) 621-6656

GCS SERVICE INC

ORLANDO, FL
(407) 841-2551
800-338-7322
FAX: (407) 423-8425

NASS PARTS AND SERVICE, INC.

1144 BELVILLE ROAD, UNIT 359
DAYTONA BEACH, FL 32114
(386) 226-2642
(800) 432-2795
(386) 736-7695 FAX

GCS SERVICE INC

TAMPA, FL
(813) 626-6044
800-282-3008
FAX: (813) 621-1174

SECTION 7: JACKSON MAINTENANCE & REPAIR CENTERS

FLORIDA TO MARYLAND

JONES-McLEOD APPLIANCE SVC

854 LAKESIDE DRIVE
MOBILE, AL 36693
(251) 666-7278
800-237-9859
FAX: (251) 661-0223
service@jones-mcleod.com

NASS PARTS AND SERVICE, INC.

1108 SOUTH WOODS AVENUE
ORLANDO, FL 32805
(407) 425-2681
(800) 432-2795
(407) 425-3463 FAX

NASS PARTS AND SERVICE, INC.

1376 HEIDE AVENUE
PALM BAY, FL 32907
(321) 952-2012
(800) 432-2795
(321) 953-0266 FAX

GEORGIA

GCS SERVICE INC

ATLANTA, GA
(770) 452-7322
800-334-3599
FAX: (770) 452-7473

HERITAGE FOODSERVICE

GROUP OF ATLANTA
2100 NORCROSS PKWY.
SUITE 130
NORCROSS, GA 30071
(770) 368-1465
866-388-9837
FAX: (866) 388-9838

WHALEY FOODSERVICE REPAIRS

109-A OWENS INDUSTRIAL DRIVE
SAVANNAH, GA 31405
(912) 447-0827
888-765-0036
FAX: (912) 447-0826

PIERCE PARTS & SERVICE

2422 ALLEN ROAD
MACON, GA 31216
(478) 781-6003
800-368-2512
FAX: (478) 781-7186

HAWAII

FOOD EQMT. PARTS & SERVICE CO.

300 PUUHALE RD.
HONOLULU, HI 96819
(808) 847-4871
FAX: (808) 842-1560
fepsco@hula.net

IDAHO

RESTAURANT APPLIANCE SVC.

7219 ROOSEVELT WAY NE
SEATTLE, WA 98115
(206) 524-8200
800-433-9390
FAX: (206) 525-2890
info@restappl.com

RON'S SERVICE

703 E 44TH STREET STE 10
GARDEN CITY, ID 83714
(208) 375-4073
FAX: (208) 375-4402

ILLINOIS

CONES REPAIR SVC.

2408 40TH AVE.
MOLINE, IL 61265
(309) 797-5323
800-716-7070
FAX: (309) 797-3631
jackb@cones.com

EICHENAUER SERVICES INC.

130 S OAKLAND ST.
DECATUR, IL 62522
(217) 429-4229
800-252-5892
FAX: (217) 429-0226
esi@esiquality.com

GCS SERVICE INC.

ELMHURST, IL
(630) 941-7800
800-942-9689
FAX: (630) 941-6048

GCS SERVICE INC.

ST. LOUIS, MO
(314) 683-7444
800-284-4427
FAX: (314) 638-0135

GENERAL PARTS, INC.

248 JAMES STREET
BENSONVILLE, IL 60106
(630) 595-3300
(800) 880-3604
FAX: (630) 595-0006

INDIANA

GCS SERVICE INC.

INDIANAPOLIS, IN
(317) 545-9655
800-727-8710
FAX: (317) 549-6286

B622 LA PAS TRAIL

INDIANAPOLIS, IN 46268
(317) 290-8060
(800) 410-9794
(317) 290-8085 FAX

IOWA

GOODWIN TUCKER GROUP

2900 DELAWARE AVENUE

DES MOINES, IA 50317
(515) 262-9308
800-372-6066
FAX: (515) 262-2936
parts@goodwintucker.com

CONES REPAIR SVC.

1056 27TH AVENUE SW
CEDAR RAPIDS, IA 52404
(319) 365-3325
800-747-3326
FAX: (319) 365-0885

KANSAS

GCS SERVICE INC.

KANSAS CITY, MO
(816) 920-5999
800-229-6477
FAX: (816) 920-7387

GENERAL PARTS, INC.

1101 E. 13TH STREET
KANSAS CITY, MO 64106
(816) 421-5400
(800) 279-9967
(816) 421-1270 FAX

KENTUCKY

CERTIFIED SERVICE CENTER

127 DISHMAN LANE
BOWLING GREEN, KY 42101
(270) 783-0012
(877) 907-0012
FAX: (270) 783-0058

CERTIFIED SERVICE CENTER

RAMCO BUSINESS PARK

4283 PRODUCE ROAD
LOUISVILLE, KY 40218
(502) 964-7007
800-637-6350
FAX: (502) 964-7202
cwalker@certifiedsc.com
droenigk@certifiedsc.com

CERTIFIED SERVICE CENTER

1051 GOODWIN DRIVE
LEXINGTON, KY 40505
(606) 254-8854
800-432-9269
FAX: (606) 231-7781
jatkings@certifiedsc.com

GCS SERVICE INC.

LOUISVILLE, KY
(502) 367-1788
800-752-6160
FAX: (502) 367-0400

GCS SERVICE INC.

LEXINGTON, KY
(606) 255-0746
800-432-9260
FAX: (606) 255-0748

LOUISIANA

HERITAGE SERVICE GROUP

1532 RIVER OAKS WEST
NEW ORLEANS, LA 70123
(504) 734-8864
(800) 499-2351
(504) 733-2559 FAX

MAINE

GCS SERVICE INC.

CHELSEA, MA
(617) 889-9393
800-225-1155
FAX: (617) 889-1222

MASSACHUSETTS RESTAU-

RANT SUPPLY

34 SOUTH STREET
SOMERVILLE, MA 02143
(617) 868-1930
800-338-6737
FAX: (617) 686-5331

PINE TREE FOOD EQUIP- MENT

175 LEWISTON ROAD
GRAY, ME 04039
(207) 657-6400
(800) 540-5427
(207) 657-5464 FAX

MARYLAND

EMR SERVICE DIVISION

700 EAST 25TH STREET
BALTIMORE, MD 21218
(410) 467-8080
800-879-4994
FAX: (410) 467-4191
baltparts@emrco.com

SECTION 7: JACKSON MAINTENANCE & REPAIR CENTERS

MARYLAND TO NEW YORK

EMR SERVICE DIVISION
106 WILLIAMSPORT CIRCLE
SALISBURY, MD 21804
(410) 543-8197
888-687-8080
FAX: (410) 548-4038
baltparts@emrco.com

EMR SERVICE DIVISION

5316 Sunnyside Ave.
Beltsville, MD 20715
(301) 931-7000
800-348-2365
FAX: (301) 931-3060
baltparts@emrco.com

GCS SERVICE INC.

SILVER SPRING, MD
(301) 585-7550 (DC)
(410) 792-0338 (BALT)
(800) 638-7278
FAX: (301) 495-4410

MASSACHUSETTS

ACE SERVICE CO.

95 HAMPTON AVE.
NEEDHAM, MA 02494
(781) 449-4220
800-225-4510 MA & NH
FAX: (781) 444-4789
taceservice@aol.com

**MASSACHUSETTS RESTAU-
RANT SUPPLY**

34 SOUTH STREET
SOMERVILLE, MA 02143
(617) 868-1930
800-338-6737
FAX: (617) 868-5331

GCS SERVICE INC.

CHELSEA, MA
(617) 889-9393
800-225-1155
FAX: (617) 889-1222

GCS SERVICE INC.

HARTFORD, CT
(860) 549-5575
800-723-1562
FAX: (860) 527-6355

**SUPERIOR KITCHEN SER-
VICE INC.**

399 FERRY STREET
EVERETT, MA 02149
(617) 389-1899
(888) 590-1899
(617) 389-1996 FAX

MICHIGAN

GCS SERVICE INC.

LIVONIA, MI
(248) 426-9500
800-772-2936
FAX: (248) 426-7555

**JACKSON SERVICE COMPA-
NY**

3980 BENSTEIN RD.
COMMERCE TWSHP, MI 48382
(248) 363-4159
800-332-4053
FAX: (248) 363-5448

GCS SERVICE INC.

GRAND RAPIDS, MI
(616) 241-0200
800-823-4866
FAX: (616) 241-0541

MINNESOTA

GCS SERVICE INC.

MINNEAPOLIS, MN
(612) 546-4221
800-345-4221
FAX: (612) 546-4286

GENERAL PARTS, INC.

11311 HAMPSHIRE AVENUE
SOUTH
BLOOMINGTON, MN 55438-
2456
(952) 944-5800
(800) 279-9980
(800) 279-9980 FAX

MISSISSIPPI

GCS SERVICE INC.

JACKSON, MS
(601) 956-7800
800-274-5954
FAX: (601) 956-1200

GCS SERVICE INC.

MEMPHIS, TN
(901) 366-4587
800-262-9155
FAX: (901) 366-4588

MISSOURI

GCS SERVICE INC.

KANSAS CITY, MO
(816) 920-5999
800-229-6477
FAX: (816) 920-7387

GCS SERVICE INC.

ST. LOUIS, MO
(314) 638-7444
800-284-4427
FAX: (314) 638-0135

KAEMMERLIN PARTS & SVC.

2728 LOCUST STREET
ST. LOUIS, MO 63103
(314) 535-2222
FAX: (314) 535-6205
petek@kps.stl.com

GENERAL PARTS, INC.

1101 EAST 13TH STREET
KANSAS CITY, MO 64106
(816) 421-5400
(800) 279-9967
(816) 421-1270 FAX

MONTANA

**RESTAURANT APPLIANCE
SVC.**

7219 ROOSEVELT WAY NE
SEATTLE, WA 98115
(206) 524-8200
800-433-9390
FAX: (206) 525-2890
info@restappl.com

NEBRASKA

GOODWIN - TUCKER GROUP

7535 D STREET
OMAHA, NE 68124
(402) 397-2880
800-228-0342
FAX: (402) 397-2881
askme@goodwintucker.com

NEVADA

**HI TECH COMMERCIAL SER-
VICE**

1840 STELLA LAKE STREET
NORTH LAS VEGAS, NV 89106
(702) 649-4616
(877) 924-4832
FAX: (702) 649-4607
larry@hitechnv.com

5454 LOUIE LANE
RENO, NV 89511
(775) 852-9696
FAX: (775) 852-5104

GCS SERVICE INC.

LAS VEGAS, NV
(702) 450-3495
800-500-9060
FAX: (702) 450-3491

NEW HAMPSHIRE

GCS SERVICE INC.

CHELSEA, MA
(617)889-9393
800-225-1155
FAX: (617) 889-1222

ACE SERVICE CO.

95 HAMPTON AVE.
NEEDHAM, MA 02494
(781) 449-4220
800-225-4510 MA & NH
FAX: (781) 444-4789
taceservice@aol.com

**MASSACHUSETTS RESTAU-
RANT SUPPLY**

34 SOUTH STREET
SOMERVILLE, MA 02143
(617) 868-1930
800-338-6737
FAX: (617) 868-5331

NEW JERSEY

JAY HILL REPAIRS

90 CLINTON RD.
FAIRFIELD, NJ 07004
(973) 575-9145
800-836-0643
FAX: (973) 575-5890
jhrepair@aol.com

GCS SERVICE INC.

EAST RUTHERFORD, NJ
(973) 614-0003
800-399-8294
FAX: (973) 614-0230

GCS SERVICE INC.

PHILADELPHIA, PA
(215) 925-6217
800-441-9115
FAX: (215) 925-6208

ELMER SCHULTZ SERVICES

201 W. WASHINGTON AVE.
PLEASANTVILLE, NJ 08232
(609) 641-0317
800-378-1641
FAX:(609) 641-8703
elmer2@erols.com

NEW YORK

**APPLIANCE INSTALLATION
AND SERVICE CORP.**

1336 MAIN STREET
BUFFALO, NY 14209
(716) 884-7425
800-722-1252
FAX: (716) 884-0410
ais@worldnet.att.net

SECTION 7: JACKSON MAINTENANCE & REPAIR CENTERS

NEW YORK TO PENNSYLVANIA

B.E.S.T. INC.

3003 GENESEE STREET
BUFFALO, NY 14225
(716) 893-6464
800-338-5011
FAX: (716) 893-6466
bestserv@aol.com

DUFFY'S EQUIPMENT SVC.

3138 ONEIDA STREET
SAUQUOIT, NY 13456
(315) 737-9401
800-443-8339
FAX: (315) 737-7132
duffyequip@aol.com

NORTHERN PARTS & SVC.

21 NORTHERN AVENUE
PLATTSBURGH, NY 12903
(518) 563-3200
800-634-5005
FAX: (800) 782-5424
info@northernparts.com

GCS SERVICE INC.

BROOKLYN, NY
(718) 486-5220
800-969-4271
FAX: (718) 486-6772

ALL SERVICE KITCHEN

EQUIPMENT REPAIR
10 CHARLES ST.
NEW HYDE PARK, NY 11040
(516) 378-1176
FAX: (516) 378-1735

ALL ISLAND REPAIRS

40-9 BURT DRIVE
DEER PARK, NY 11729
(631) 242-5588
FAX: (631) 242-6102

NORTH CAROLINA

AUTHORIZED APPLIANCE

SERVICECENTER
1020 TUCKASEEGEE RD.
CHARLOTTE, NC 28208
(704) 377-4501
(800) 532-6127
FAX:(704) 377-4504

AUTHORIZED APPLIANCE

SERVICECENTER
800 N. PERSON ST.
RALEIGH, NC 27604
(919) 834-3476
FAX:(919) 834-3477

AUTHORIZED APPLIANCE

SERVICECENTER
904 S. MARSHALL ST.
WINSTON-SALEM, NC 27403
(336) 725-5396
FAX:(336) 721-1289

AUTHORIZED APPLIANCE

SERVICECENTER
104 HINTON AVE.
WILMINGTON, NC 28403
(910) 313-1250
FAX:(910) 313-6130

WHALEY FOODSERVICE

8334-K ARROWRIDGE BLVD
CHARLOTTE, NC 28273
(704) 529-6242
FAX: (704) 529-1558
info@whaleyfoodservice.com

WHALEY FOODSERVICE

REPAIRS
203-D CREEK RIDGE RD.
GREENSBORO, NC 27406
(336) 333-2333
FAX: (336) 333-2533
info@whaleyfoodservice.com

WHALEY FOODSERVICE

REPAIRS
335-105 SHERWEE DRIVE
RALEIGH, NC 27603
(919) 779-2266
FAX: (919) 779-2224
info@whaleyfoodservice.com

WHALEY FOODSERVICE

REPAIRS
6418-101 AMSTERDAM WAY
WILMINGTON, NC 28405
(910) 791-0000
FAX: (910) 791-6662
info@whaleyfoodservice.com

NORTH DAKOTA

GCS SERVICE INC.

MINNEAPOLIS, MN
(612) 546-4221
800-345-4221
FAX: (612) 546-4286

GENERAL PARTS, INC.

10 SOUTH 18TH STREET
FARGO, ND 58103
(701) 235-4161
(800) 279-9987
(701) 235-0539 FAX

OHIO

CERTIFIED SERVICE CENTER

890 REDNA TERRACE
CINCINNATI, OH 45215
(513) 772-6600
800-543-2060
FAX: (513) 612-6600
sbarasch@certifiedsc.com

CERTIFIED SERVICE CENTER

171J-K NORTH HAMILTON RD.
COLUMBUS, OH 43213
(614) 751-3769
(866) 862-1252
FAX: (614) 751-5792
jadkins@certifiedsc.com

CERTIFIED SERVICE CENTER

6025 N. DIXIE DRIVE
DAYTON, OH 45414
(937) 898-4040
(800) 257-2611
FAX: (937) 898-4177
dharvey@certifiedsc.com

COMMERCIAL PARTS & SVC.

OF COLUMBUS
5033 TRANSAMERICA DRIVE
COLUMBUS, OH 43228
(614) 221-0057
800-837-8327
FAX: (614) 221-3622

GCS SERVICE INC.

COLUMBUS, OH
(614) 476-3225
800-282-5406
FAX: (614) 476-1196

ELECTRICAL APPLIANCE

REPAIR SVC.
5805 VALLEY BELT ROAD
CLEVELAND, OH 44131
(216) 459-8700
800-621-8259
FAX: (216) 459-8707
tomr@electapprep.com

OKLAHOMA

HAGAR RESTAURANT EQMT.

1229 W MAIN STREET
OKLAHOMA CITY, OK 73106
(405) 235-2184
800-445-1791
FAX: (405) 236-5592

OREGON

RON'S SERVICE

16364 SW 72ND AVE
PORTLAND, OR 97224
(503) 624-0890
800-851-4118
FAX: (503) 684-6107
robinson@ronsservice.com

PENNSYLVANIA

A.I.S. COMMERCIAL PARTS & SERVICE

1816 WEST 26TH STREET
ERIE, PA 16508
(814) 456-3732
800-332-3732
FAX: (814) 452-4843
aiserie@aol.com

ELMER SCHULTZ SVC.

540 NORTH 3RD STREET
PHILADELPHIA, PA 19123
(215) 627-5400
FAX: (215) 627-5408
elmer2@erols.com

GCS SERVICE INC.

PHILADELPHIA, PA
(215) 925-6217
800-441-9115
FAX: (215) 925-6208

GCS SERVICE INC.

HARRISBURG, PA
(717) 564-3282
800-367-3225
FAX: (717) 564-9286

GCS SERVICE INC.

PITTSBURGH, PA
(412) 787-1970
800-738-1221
FAX: (412) 787-5005

K & D PARTS AND SERVICE CO.

1833-41 N CAMERON STREET
HARRISBURG, PA 17103
(717) 236-9039
800-932-0503
FAX: (717) 238-4367
kdparts-service@paonline.com

CLARK SERVICE & PARTS

306 AIRPORT DRIVE
BOX 10
SMOKETOWN, PA 17576
(717) 392-5590
(717) 392-5735

SECTION 7: JACKSON MAINTENANCE & REPAIR CENTERS

RHODE ISLAND TO WISCONSIN

RHODE ISLAND

GCS SERVICE INC.
EAST PROVIDENCE, RI
(401) 434-6803
800-462-6012
FAX: (401) 438-9400

SUPERIOR KITCHEN SERVICE INC.

669 ELMWOOD AVENUE
PROVIDENCE, RI 02907
(888) 590-1899
(401) 781-1996 FAX

SOUTH CAROLINA

AUTHORIZED APPLIANCE SERVICECENTER

1811 TAYLOR ST.
COLUMBIA, SC 29202
(803) 254-8414
FAX: (803) 254-5146

AUTHORIZED APPLIANCE SERVICECENTER

2249 AUGUSTA RD.
GREENVILLE, SC 29605
(864) 235-9616
FAX: (864) 235-9623

WHALEY FOODSERVICE REPAIRS

I 26&US1
P.O. BOX 4023
WEST COLUMBIA, SC 29170
(803) 791-4420
800-877-2662
FAX: (803) 794-4630
info@whaleyfoodservice.com

WHALEY FOODSERVICE REPAIRS

748 CONGAREE ROAD
GREENVILLE, SC 29607
(864) 234-7011
800-494-2539
FAX: (864) 234-6662
info@whaleyfoodservice.com

WHALEY FOODSERVICE REPAIRS

1406-C COMMERCE PL.
MYRTLE BEACH, SC 29577
(843) 626-1866
FAX: (843) 626-2632
info@whaleyfoodservice.com

WHALEY FOODSERVICE REPAIRS

4740-A FRANCHISE STREET
N. CHARLESTON, SC 29418
(843) 760-2110
FAX: (843) 760-2255
info@whaleyfoodservice.com

SOUTH DAKOTA

GCS SERVICE INC.

MINNEAPOLIS, MN
(612) 546-4221
800-345-4221
FAX: (612) 546-4286

GENERAL PARTS, INC.

10 SOUTH 18TH STREET
FARGO, ND 58103
(701) 235-4161
(800) 279-9987
(701) 235-0539 FAX

TENNESSEE

GCS SERVICE INC.

MEMPHIS, TN
(901) 366-4587
800-262-9155
FAX: (901) 366-4588

GCS SERVICE INC.

NASHVILLE, TN
(615) 244-8050
800-831-7174
FAX: (615) 244-8885

TEXAS

ARMSTRONG REPAIR CENTER

5110 GLENMOUNT DRIVE
HOUSTON, TX 77081
(713) 666-7100
800-392-5325
FAX: (713) 661-0520
gm@armstrongrepair.com

COMMERCIAL KITCHEN REPAIR CO.

1377 N BRAZOS
P.O BOX 831128
SAN ANTONIO, TX 78207
(210) 735-2811
800-292-2120
FAX: (210) 735-7421
brock@commercialkitchen.com

GCS SERVICE INC.

DALLAS, TX
(972) 484-2954
800-442-5026
FAX: (972) 484-2531

GCS SERVICE INC.

HOUSTON, TX
(713)785-9187
800-868-6957
FAX: (713) 785-3979

GCS/STOVE PARTS

2120 SOLANA STREET
FORT WORTH, TX 76117
(817) 831-0381
800-433-1804
FAX: (817) 834-7754
bud@stoveparts.com

UTAH

LA MONICA'S RESTAURANT EQMT. SVC.

6182 SOUTH STRATLER AVENUE
MURRAY, UT 84107
(801) 263-3221
800-527-2561
FAX: (801) 263-3229
lamonica81@aol.com

VERMONT

NORTHERN PARTS & SVC.

4874 S. CATHERINE STREET
PLATTSBURGH, NY 12901
(518) 563-3200
800-634-5005
FAX: (800) 782-5424
info@northernparts.com

GCS SERVICE INC.

CHELSEA, MA
(617)889-9393
800-225-1155
FAX: (617) 889-1222

VIRGINIA

DAUBERS, INC.

7645 DYNATECH COURT
SPINGFIELD, VA 22153
(703) 866-3600
800-554-7788
FAX: (703) 866-4071
daubers@aol.com

GCS SERVICE INC.

SILVER SPRING, MD
(301) 585-7550(DC)
(410) 792-0388(BALT)
800-638-7278
FAX: (301)495-4410

GCS SERVICE INC.

RICHMOND, VA
(804) 672-1700
800-899-5949
FAX: (804) 672-2888

GCS SERVICE INC.

VIRGINIA BEACH, VA
(757) 464-3500
800-476-4278
FAX: (757) 464-4106

WASHINGTON

GCS SERVICE INC.

SEATTLE, WA
(206) 763-0353
800-211-4274
FAX: (206) 763-5943

RESTAURANT APPLIANCE SERVICE

7219 ROOSEVELT WAY, NE
SEATTLE, WA 98115
(206) 524-8200
800-433-9390
FAX: (206) 525-2890
info@restappl.com

WEST VIRGINIA

STATEWIDE SERVICE, INC.

603 MAIN AVE.
NITRO, WV 25143
(304) 755-1811
(800) 441-9739
FAX: (304) 755-4001
sws3182@aol.com

WISCONSIN

APPLIANCE SERVICE CENTER, INC.

2439 ATWOOD AVE
MADISON, WI 53704
(608) 246-3160
800-236-7440
FAX: (608) 246-2721
ascmad@execpc.com

APPLIANCE SERVICE CENTER, INC.

6843 W. BELOIT RD.
WEST ALLIS, WI 53219
(414) 543-6460
800-236-6460
FAX: (414) 543-6480
ascmil@execpc.com

APPLIANCE SERVICE CENTER

786 MORRIS AVE
GREEN BAY, WI 54304
(920) 496-9993
800-236-0871
FAX: (920) 496-9927
ascfox@execpc.com

SECTION 7: JACKSON MAINTENANCE & REPAIR CENTERS

WISCONSIN TO WYOMING/INTERNATIONAL

GENERAL PARTS, INC.

W223 N735 SARATOGA DRIVE
WAUKESHA, WI 53186
(262) 650-6666
(800) 279-9946
(262) 650-6660 FAX

WYOMING

HAWKINS COMMERCIAL APPLIANCE SERVICE

3000 S. WYANDOT ST.
ENGLEWOOD, CO 80110
(303) 781-5548
(800) 624-2117
FAX: (303) 761-5561
johns@hawkinscommercial.com

METRO APPLIANCE SERVICE

1640 S BROADWAY
DENVER, CO 80210
(303) 778-1126
800-525-3532
FAX: (303) 778-0268
metroappls@aol.com

INTERNATIONAL

GLOBAL PARTS AND SUPPLY

7758 NW 72ND ST
MIAMI, FL 33166
(305) 885-6353

H.D. SHELDON AND CO

19 UNION SQUARE, WEST
NEW YORK, NY 10003
(212) 627-1759
(212) 924-6920

CANADA

THE GARLAND GROUP

1177 KAMATO ROAD
MISSISSAUGA, ONTARIO L4W
1X4
(905) 206-8380
SALES
(905) 624-1419
FAX: (905) 624-1851
SERVICE
800-427-6668
FAX: 800-361-7745

March 13, 2007

