



Outperform every day.™

# Operator's Manual

## 68 Inch Digital Conveyor Pizza Ovens

Model MGD18

Thank you for purchasing this Vollrath equipment. Before operating the equipment, read and familiarize yourself with the following operating and safety instructions. **SAVE THESE INSTRUCTIONS FOR FUTURE REFERENCE.** Save the original box and packaging. Use this packaging to ship the equipment if repairs are needed.

### SAFETY PRECAUTIONS

To ensure safe operation, read the following statements and understand their meaning. This manual contains safety precautions which are explained below. Please read carefully.

#### **WARNING**

Warning is used to indicate the presence of a hazard that will or can cause severe personal injury or death.

#### **CAUTION**

Caution is used to indicate the presence of a hazard that will or can cause minor or major personal injury if the caution is ignored.

**NOTICE:** Notice is used to note information that is important but not hazard-related.

#### **To reduce risk of injury or damage to the equipment**

- Plug only into grounded electrical outlets matching the voltage on the rating plate.
- Use this equipment in a flat, level position.
- Unplug equipment and let it cool before cleaning or moving. Equipment remains hot after it is turned off.
- Unplug when not in use.
- Keep equipment and power cord away from open flames, electric burners or excessive heat.
- Do not operate unattended.
- Closely supervise equipment operating in public areas and/or around children.
- Do not operate if equipment has been damaged or is malfunctioning.



Item No.	Model	Description
P06-20818		18" wide conveyor, 208V
P06-22018	MGD18	18" wide conveyor, 220V
P06-24018		18" wide conveyor, 240V

### FUNCTION AND PURPOSE

This equipment is intended to bake fresh dough and par-baked pizzas, flat breads, calzones and toast sandwiches. It is not intended to bake frozen or deep dish pizzas, or to cook raw food or raw pizza toppings. It is intended for use in commercial foodservice operations that serve pizzas, but that also serve other menu items. It is intended for occasional, not continuous use. It is not intended for pizzerias, household, industrial or laboratory use.

### CLEARANCE AND ENVIRONMENT REQUIREMENTS

Do not place this oven on surfaces or near walls, partitions or kitchen furniture unless they are made of non-combustible material or clad with non-combustible heat-insulating material. Ovens must not be used near or below curtains and other combustible materials. Do not place the oven adjacent to a heat producing appliance.

Register your product at [Vollrath.com/registration](http://Vollrath.com/registration) and become eligible to win a free 10" Vollrath Tribute® fry pan.

---

## SET UP

---

1. Place the oven on a hard, flat, stable surface.
2. Install the legs. Two people required. Have one person lift one end of the oven while the other person installs the legs. Repeat for the other side of the oven.

**NOTICE: Legs must be installed. Failure to install the legs will restrict airflow and cause the oven to overheat.**

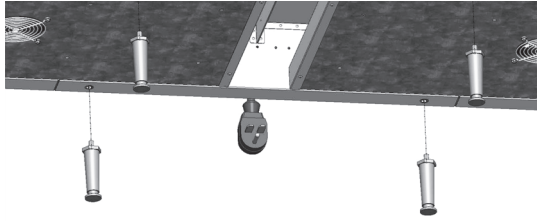

3. Install the load and unload trays to match the conveyor direction. The load tray slants toward the conveyor. The unload tray slants away from the conveyor.

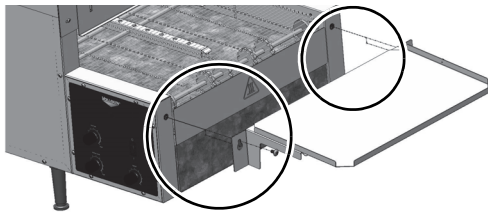
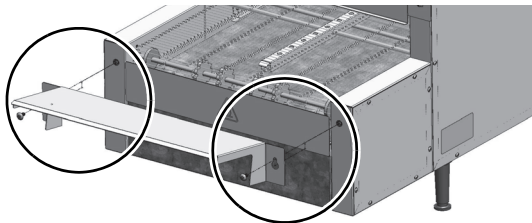

---

## BEFORE FIRST USE

---

1. Clean the oven. See “Daily Cleaning” on page 5.

---

## FROZEN/FRESH DOUGH HANDLING TIPS

---

The following are general tips. Follow any instructions specific to your brand of dough or recipe.

- Remove the wrapping from frozen dough balls.
- Place the dough balls a few inches apart, into a proofing box or on a sheet pan.
- Lightly spray top of the dough balls with a non-stick cooking spray, then cover with a layer of freezer paper.
- Refrigerate overnight.
- Remove only enough dough balls from the sheet pan to accommodate what you will need for a few hours.
- Sprinkle flour, cornmeal or Pizza Crisp onto the surface on which you plan to roll out the dough.
- Roll the dough, starting from the center and working your way to the outer edges. Turn the dough as you work toward the outer edges to maintain a round shape.
- Use a rolling pin, dough press or dough sheeter to form the dough to the desired size and thickness.
- Place the flattened shell onto a dark metal or seasoned pizza screen or pan.

**NOTICE: Fresh dough pizzas must be baked on metal pizza screens or pizza pans. Do NOT put fresh dough pizzas directly on the conveyor. Dough will stick to or fall through the conveyor.**

**NOTICE: Do NOT use paper pizza pans in this oven. Paper pizza pans will burn and could create a fire hazard.**

**NOTICE: Dark metal or seasoned metal screens or pans perform best. Shiny metal or aluminum foil will reflect heat away from the pizza and preventing browning.**

---

## PIZZA ASSEMBLY TIPS

---

- Spread the sauce, starting from the center and moving toward the outer edges of the crust to ensure a uniform thickness of sauce. Leave an inch of space to the outer edge of the crust to allow the crust to brown. Spreading sauce too close to the edge prevents the crust from browning.
- Spread out high moisture content toppings, such as vegetables. High moisture toppings will prevent the surrounding areas from baking until ALL of the moisture has evaporated.

# FEATURES

Left to Right Conveyor Set-up Shown

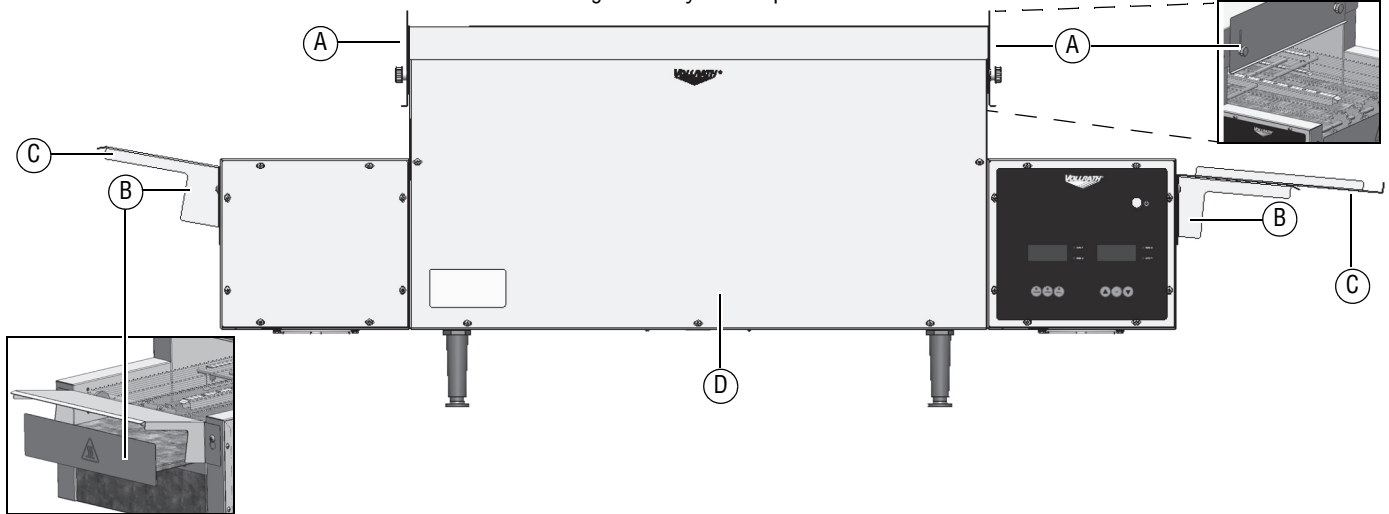

## Front View

- A Heat Shield**
- B Crumb Tray**
- C Load/Unload Trays**
  - Load** Slants toward conveyor
  - Unload** Slants away from conveyor
- D Reset Button** (Reference only. See page 6.)

## Back View

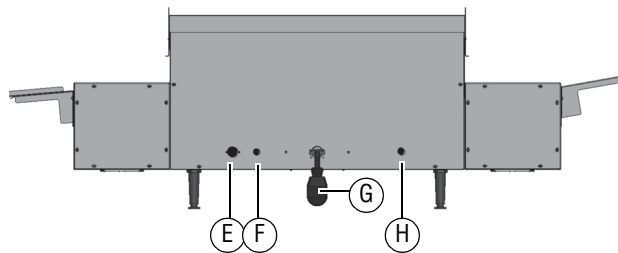

- E 15A Circuit Breaker**
- F 5A Circuit Breaker**
- G Power Cord**
- H Main Power Switch** - Turns on main power to the oven

## Control Panel



**Power Button** - Press to turn on the heating elements and conveyor.



**Speed Button** - Press to set the time it takes for food to pass through the oven.



**Recipe Button** - Press to select a recipe. There are six customizable recipe programs. Each recipe includes temperature settings for each oven zone and the conveyor speed.

**Pizza 1-2** Select for pizzas that have 1-2 topping

**Pizza 3-4** Select for pizzas that have 3-4 toppings

**Calzone** Select for baking fresh dough calzones

**Sandwich** Select for toasting sandwiches

**M1** Create your own recipe program

**M2** Create your own recipe program



**Temp Button** - There are four temperature zones, two on top of the oven and two on the bottom. For a diagram, see "Change Temperatures" on page 5.



**Up Button** - Press to scroll through the recipes or to increase the speed or temperature.



**Set Button** - Press to select a recipe or save a change to the speed or temperature.



**Down Button** - Press to scroll through the recipes or to decrease the speed or temperature.

# OPERATION

## Preheat

1. Plug the oven into a grounded electrical outlet that matches the rating on the name plate found on the oven.

**NOTICE: Using a voltage other than the nameplate rated voltage will cause damage to the unit. Incorrect voltage, modification to the power cord or electrical components can damage unit and will void the warranty.**

2. Rotate the knobs to adjust the heat shields to allow food to pass into the oven, and to regulate the amount of heat retained at each end of the oven to achieve desired results.

### Tips:

Menu Item	Suggestions
Fresh dough	Entry shield all the way down, and exit shield partially down to retain heat to bake the dough.
Par baked	Entry and exit shields half way down to finish crust and brown the toppings.
Sandwich	Entry and exit shields half way down.
Calzone	Entry and exit shields half way down.

3. Position the main power switch on the back of oven to the ON position.

4. Press and release  on the display. You will hear a beep. The oven will start to preheat. The display will read:



5. The oven will be ready to use in approximately 20 minutes. The display will read:



6. Press and release .

7. Press  to scroll through the recipe options.

8. Press and release  to select a recipe.

9. Adjust the recipe settings according to the menu item to be baked. See "Adjust the Recipe Settings" on this page.

10. Wait 5 minutes for the oven to adjust to the new settings.

## Test

**NOTICE: Fresh dough pizzas must be baked on metal pizza screens or pizza pans. Do NOT put fresh dough pizzas directly on the conveyor. Dough will stick to or fall through the conveyor.**

**NOTICE: Do NOT use paper pizza pans in this oven. Paper pizza pans will burn and could create a fire hazard.**





**NOTICE: Dark metal or seasoned metal screens and pans perform best. Shiny metal or aluminum foil will reflect heat away from the pizza and preventing browning.**

1. Test the settings by placing a sample pizza into the oven.
2. Monitor the baking process and adjust the temperatures and conveyor speed to prevent the pizza from burning.
3. Evaluate the results.

## Adjust the Recipe Settings

Customize the default recipe settings to meet your baking needs.

### STEP 1: Select a Recipe to Adjust

1. Press and release . The control panel will beep.
2. Press and release  or  to scroll through the recipes.
3. Press and release  to select a recipe.

**Note:** Press set within 10 seconds or the change will not be saved.

### STEP 2: Select Settings to Adjust

#### Change the Conveyor Speed

1. Press and release . The current speed will display.

**Tip:** For pizza start with a 7:30 pass time. Ideal pass time is dependent on the type of crust and toppings.

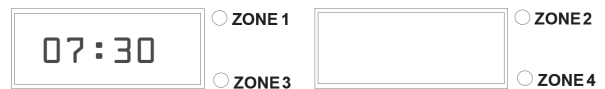

2. Press and release the  or  to change the speed.

3. Press and release  to select and save the selection.

#### Change the Temperatures

1. There are four temperature zones. Zones are always in the same location, regardless of the direction of the conveyor.

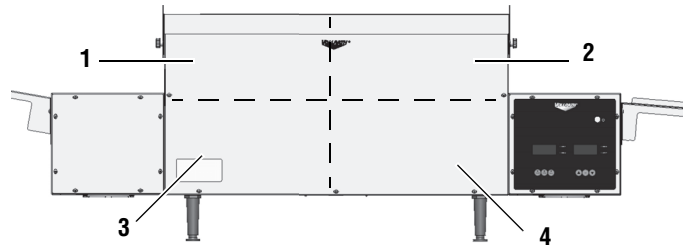

#### Conveyor Direction Pizza Direction Through Zones

- Left to Right      1 and 3 → 2 and 4  
 Right to Left      1 and 3 ← 2 and 4

2. Press and release . Zone 1 is displayed.

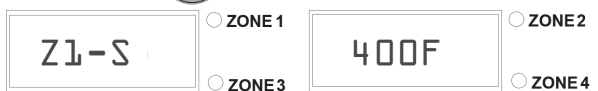

3. Press and release  or  to change the temperature.



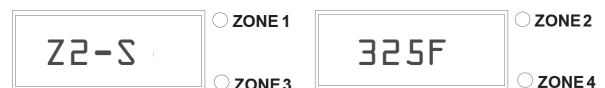

**Tip:** For pizza, set the bottom heat approximately 75° to 100° degrees hotter than the top control. Ideal temperatures are dependent on the type of crust and toppings.

4. Press and release  to save the selection. The display will advance to next heat zone.





## OPERATION (CONTINUED)

### Bake

1. Press and release . The control panel will beep.
2. Press and release  or  to scroll through the recipes.
1. Press and release  to select a recipe.
2. Allow time for the oven to adjust to new heat settings before placing a pizza on the conveyor.
3. Do not overload the oven. Wait a few minutes for the oven to recover before placing the next pizza onto the conveyor.  
**Maximum oven capacity:** One 16" diameter pizza or multiple smaller pizzas with a combined maximum diameter of 16"

### If a Pizza is Stuck in the Oven

1. Press and hold  until the display shows  
  ZONE 1   ZONE 2  
 ZONE 3  ZONE 4
2. Unplug the oven.
3. Let the oven cool completely.
4. Use tongs to remove the pizza. Take care to not bump the glass heating elements above and below the conveyor.





### Change the Conveyor Direction

1. Press and hold the  until you hear two beeps.
2. The conveyor will stop. After about 10 seconds it will start again in the opposite direction.





### Standby Mode

Use standby mode to reduce electrical consumption by up 75% during non-peak usage time.

#### To Place the Oven in Standby Mode

1. Press and release  and  at the same time.
2. The display will show  
  ZONE 1   ZONE 2  
 ZONE 3  ZONE 4

#### To Cancel Standby Mode

1. Press any button on the control panel to return the oven to full power.
2. The display will show WARMING until the oven reaches the temperature for the selected recipe.  
  ZONE 1   ZONE 2  
 ZONE 3  ZONE 4
3. When the oven reaches the set temperature, the display will show  
  ZONE 1   ZONE 2  
 ZONE 3  ZONE 4



## CLEANING

	<b>WARNING</b> <b>Electrical Shock Hazard</b> Do not spray water or cleaning products. Liquid could contact the electrical components and cause a short circuit or an electrical shock.
---	---

	<b>CAUTION</b> <b>Burn Hazard</b> Allow equipment to cool before moving or cleaning.
---	--

**NOTICE:** Do not use abrasive materials, scratching cleansers or scouring pads to clean the exterior of the equipment. These can damage the finish.

### Daily Cleaning

1. Press and hold  until the display shows  
  ZONE 1   ZONE 2  
 ZONE 3  ZONE 4
2. Unplug the oven.
3. Let the oven cool completely.
4. Slightly dampen a soft cloth with a warm water.
5. Use the dampened cloth to clean the exterior of the oven, the air intake under the oven, the feed ramp, and collection tray.

### Clean the Conveyor

**Tip:** Use M1 or M2 to create a "recipe" with settings for cleaning the oven,

1. Plug in the oven.
2. Press and release .
3. Set the temperature in all 4 zones to 150°.
4. Set the conveyor speed to 90 seconds.
5. Press and hold a heat resistant (steel wool, metal wire brush, etc) abrasive pad or brush against the conveyor. Move the pad or brush back and forth (left to right) across the conveyor to remove food debris.
6. Empty and clean the crumb trays.

	<b>CAUTION</b> <b>Burn Hazard</b> Crumb trays may be hot. Use oven mitts to protect hands.
---	--

## PREVENTATIVE MAINTENANCE

Contact an authorized service agent for a professional cleaning of the components.

## TROUBLESHOOTING

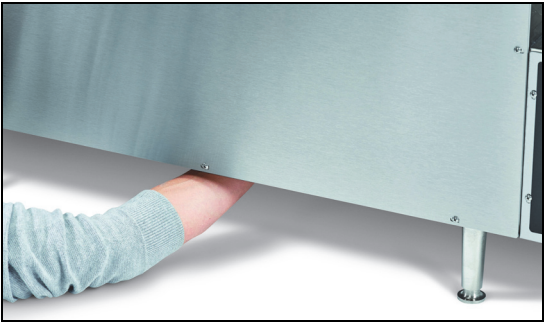
Problem	Might be Caused By	Course of Action
Oven will not turn on when the power button on the front of the oven is pressed.	Master On/Off switch on the back of the oven is in the OFF position.	Position the switch to the ON position.
	Oven is plugged into incorrect voltage.	Check voltage at the wall outlet. Plug oven into correct voltage.
Display on control panel is blank, oven is plugged in and turned on.	15 amp circuit breaker, located on the back of the oven, may have tripped.	Check for a broken heater tube. Replace the heater tube. After the issue has been resolved, press the button on the circuit breaker to reset it.
Display shows an zone alarm: prb1, prb2, prb3, prb4 and the control panel emits a continuous beep.	Temperature probe in the zone indicated by the alarm code is not responding.	Press any key to turn off the alarm. Contact Vollrath Technical Services.
Display will not change from Warming to Redy.	One heat zone may not be on.	Examine heater tubes in each heat zone to verify they are working.
	Oven is plugged into incorrect voltage.	Check voltage at the wall outlet. Plug oven into correct voltage.
Display changes from Warming to Heating and does not display Redy.	Temperature setting in one or more zones may be too high.	Maximum temperature for each zone is 550°F. Adjust the temperatures to below the maximum.
Conveyor will not reverse direction.	The conveyor may be obstructed.	Check for and clear obstructions in the conveyor.
	The speed button was not been pressed correctly.	Press and hold the speed button until you hear two beeps.
	There may be a problem with the drive system relay.	Contract Vollrath Technical Services.
Conveyor speed will not change.	Set button was not pressed after setting the new speed.	Press the Set button after changing the speed. See “Change the Conveyor Speed” on page 4.
	There may be a problem with the driver board.	Contract Vollrath Technical Services.
Conveyor will not turn, but the oven heats.	The conveyor may be obstructed.	Check for and clear obstructions in the conveyor.
	There may be a problem with one of the components.	Contact Vollrath Technical Services.
	5 amp circuit breaker, located on the back of the oven, may have tripped.	Press the button on the circuit breaker to reset it.
Top or bottom heater tubes do not heat.	One or more heater tubes may have burned out in the zone indicated by the alarm code shown on the display.	Press any key to turn off the alarm. Contact Vollrath Technical Services.
Oven repeatedly overheats.	The crumb tray may not be installed.	Verify the crumb tray is installed.
	The fan may be dirty.	Verify the fan blades are clean.
	The fan blades may be dirty.	Inspect the fan blades to see if they are dirty. <ol style="list-style-type: none"> <li>1. Press and hold the power button on the front of the oven until the display shows OFF. Unplug the oven.</li> <li>2. Wait 30 minutes for the oven cool.</li> <li>3. Clean the fan blades.</li> <li>4. Plug in the oven.</li> <li>5. Press the power button on the front of the oven.</li> <li>6. Press the reset button.</li> </ol> 
		7. If the problem persists call Vollrath Technical Services.
	There may be a problem with the fan.	Run the oven for 10 minutes. If the fan does not run, contact Vollrath Technical Services.
The fan is not running.	There may be a problem with the fan or fan switch.	Run the oven for 10 minutes. If the fan does not run, contact Vollrath Technical Services.
The oven is turned off and the fan is running.	Normal operation. The fan turns on as needed to cool the oven.	–

This page intentionally left blank.

---

## SERVICE AND REPAIR

---

When under warranty, repair is available for this product. To begin the process:

1. Contact Vollrath Technical Services at 1-800-309-2250. Please be ready with the item number, model number and serial number. You can find this information on the nameplate located on the side or back of the equipment. Also please provide a proof of purchase indicating the date the equipment was purchased.
2. A technical services representative will help you troubleshoot the problem over the phone.
3. If the representative determines the issue requires professional service, he or she will help you locate an authorized service center.
4. Contact the authorized service center to make arrangements for the repair. Vollrath will cover the cost to repair and/or replace defective parts within the equipment warranty period.

---

## WARRANTY STATEMENT FOR THE VOLLRATH CO. L.L.C.

---

The Vollrath Company LLC warrants the products it manufactures or distributes against defects in materials and workmanship as specifically described in our full warranty statement. In all cases, the warranty runs from the date of the end user's original purchase date found on the receipt. Any damages from improper use, abuse, modification or damage resulting from improper packaging during return shipment for warranty repair will not be covered under warranty.

The warranty does not apply to products purchased for personal, family or household use, and The Vollrath Company LLC does not offer a written warranty to purchasers for such uses.

Warranted Parts: The warranty period is 2 years parts, 1 year labor.

Heater Tubes: The warranty period is 1 year, including labor. Heater tube glass damage is not covered by this warranty.

For complete warranty information, product registration and new product announcements, visit [www.vollrath.com](http://www.vollrath.com).



Outperform every day.™

[www.vollrath.com](http://www.vollrath.com)

### The Vollrath Company, L.L.C.

1236 North 18th Street  
Sheboygan, WI 53081-3201 U.S.A.  
Main Tel: 800.624.2051 or 920.457.4851  
Main Fax: 800.752.5620 or 920.459.6573  
Customer Service: 800.628.0830  
Canada Customer Service: 800.695.8560

### Technical Services

[techservicereps@vollrathco.com](mailto:techservicereps@vollrathco.com)  
Toasters: 1-800-309-2250  
All Other Products: 800.628.0832