

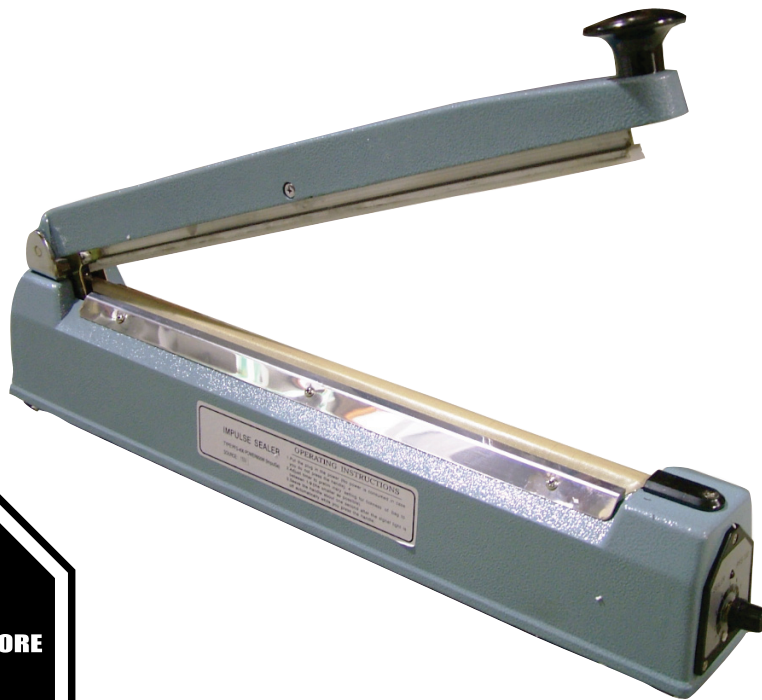

## ***Impulse Sealers***

*Models SE-CN-0203, 0305, 0406 and 0508  
Items 14446, 14448, 14450, 14451*

## ***Instruction Manual***



*Revised - 02/07/2018*



Toll Free: 1-800-465-0234  
Fax: 905-607-0234  
Email: [service@omcan.com](mailto:service@omcan.com)  
[www.omcan.com](http://www.omcan.com)

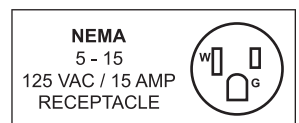

# ***Table of Contents***

Model SE-CN-0203 / Model SE-CN-0305  
Model SE-CN-0406 / Model SE-CN-0508

---

<b>Section</b>	<b>Page</b>
General Information -----	3 - 4
Safety and Warranty -----	4 - 5
Technical Specifications -----	5 - 6
Operation -----	6 - 7
Parts Breakdown -----	7 - 9
Electrical Schematics -----	10
Warranty Registration -----	11



# General Information

---

Omcan Manufacturing and Distributing Company Inc., Food Machinery of America, Inc. dba Omcan and Omcan Inc. are not responsible for any harm or injury caused due to any person's improper or negligent use of this equipment. The product shall only be operated by someone over the age of 18, of sound mind, and not under the influence of any drugs or alcohol, who has been trained in the correct operation of this machine, and is wearing authorized, proper safety clothing. Any modification to the machine voids any warranty, and may cause harm to individuals using the machine or in the vicinity of the machine while in operation.

## CHECK PACKAGE UPON ARRIVAL

Upon receipt of an Omcan shipment please inspect for external damage. If no damage is evident on the external packaging, open carton to ensure all ordered items are within the box, and there is no concealed damage to the machine. If the package has suffered rough handling, bumps or damage (visible or concealed), please note it on the bill of lading before accepting the delivery and contact Omcan within 24 hours, so we may initiate a claim with the carrier. A detailed report on the extent of the damage caused to the machine must be filled out within three days, from the delivery date shown in the shipping documents. Omcan has no recourse for damaged products that were shipped collect or third party.

**Before operating any equipment, always read and familiarize yourself with all operation and safety instructions.**

Omcan would like to thank you for purchasing this machine. It's of the utmost importance to save these instructions for future reference. Also save the original box and packaging for shipping the equipment if servicing or returning of the machine is required.

---

Omcan Fabrication et distribution Compagnie Limitée et Food Machinery d'Amérique, dba Omcan et Omcan Inc. ne sont pas responsables de tout dommage ou blessure causé du fait que toute personne ait utilisé cet équipement de façon irrégulière. Le produit ne doit être exploité que par quelqu'un de plus de 18 ans, sain d'esprit, et pas sous l'influence d'une drogue ou d'alcool, qui a été formé pour utiliser cette machine correctement, et est vêtu de vêtements de sécurité appropriés. Toute modification de la machine annule toute garantie, et peut causer un préjudice à des personnes utilisant la machine ou des personnes à proximité de la machine pendant son fonctionnement.

## VÉRIFIEZ LE COLIS DÈS RÉCEPTION

Dès réception d'une expédition d'Omcan veuillez inspecter pour dommages externes. Si aucun dommage n'est visible sur l'emballage externe, ouvrez le carton afin de s'assurer que tous les éléments commandés sont dans la boîte, et il n'y a aucun dommage dissimulé à la machine. Si le colis n'a subi aucune mauvaises manipulations, de bosses ou de dommages (visible ou cachée), notez-le sur le bond de livraison avant d'accepter la livraison et contactez Omcan dans les 24 heures qui suivent, pour que nous puissions engager une réclamation auprès du transporteur. Un rapport détaillé sur l'étendue des dommages causés à la machine doit être rempli dans un délai de trois jours, à compter de la date de livraison indiquée dans les documents d'expédition. Omcan n'a aucun droit de recours pour les produits endommagés qui ont été expédiés ou cueilli par un tiers transporteur.

# General Information

---

Avant d'utiliser n'importe quel équipement, toujours lire et vous familiariser avec toutes les opérations et les consignes de sécurité.

Omcan voudrais vous remercier d'avoir choisi cette machine. Il est primordial de conserver ces instructions pour une référence ultérieure. Également conservez la boîte originale et l'emballage pour l'expédition de l'équipement si l'entretien ou le retour de la machine est nécessaire.

---

Omcan Empresa De Fabricacion Y Distribucion Inc. Y Maquinaria De Alimentos De America, Inc. dba Omcan y Omcan Inc. no son responsables de ningun daño o perjuicio causado por cualquier persona inadecuada o el uso descuidado de este equipo. El producto solo podra ser operado por una persona mayor de 18 años, en su sano juicio y no bajo alguna influencia de droga o alcohol, y que este ha sido entrenado en el correcto funcionamiento de esta máquina, y ésta usando ropa apropiada y autorizada. Cualquier modificación a la máquina anula la garantía y puede causar daños a las personas usando la máquina mientras esta en el funcionamiento.

## REVISE EL PAQUETE A SU LLEGADA

Tras la recepcion de un envio Omcan favor inspeccionar daños externos. Si no hay daños evidentes en el empaque exterior, Habra el carton para asegurarse que todos los articulos solicitados estén dentro de la caja y no encuentre daños ocultos en la máquina. Si el paquete ha sufrido un manejo de poco cuidado, golpes o daños (visible o oculto) por favor anote en la factura antes de aceptar la entrega y contacte Omcan dentro de las 24 horas, de modo que podamos iniciar una reclamación con la compañía. Un informe detallado sobre los daños causados a la máquina debe ser llenado en el plazo de tres días, desde la fecha de entrega que se muestra en los documentos de envío. Omcan no tiene ningun recurso por productos dañados que se enviaron a recoger por terceros.

Antes de utilizar cualquier equipo, siempre lea y familiarizarse con todas las instrucciones de funcionamiento y seguridad.

Omcan le gustaría darle las gracias por la compra de esta máquina. Es de la mayor importancia para salvar estas instrucciones para futuras consultas. Además, guarda la caja original y el embalaje para el envío del equipo si servicio técnico o devolución de la máquina que se requiere.

# Safety and Warranty

---

The Impulse Sealer is used to ensure a water tight and air tight seal for effective packing and sterilization procedures.

- Place the unit on a flat, level surface.
- Do not place any flammable or explosive objects around the unit.
- Thoroughly read this manual before installing the unit.
- Always keep the sealing platform clean. Leaving residue will reduce the life of the element, non-stick



# Safety and Warranty

material and silicon rubber.

- Never use water to clean the sealing surface.
- Replace torn non-stick material immediately. A torn surface will short circuit the element and damage the unit. Every time you replace the element, replace the lower and upper non-stick material.
- For best operation, use only genuine replacement parts.
- A worn silicon rubber will influence the seal, change the silicon when worn or burned.

## 1 YEAR PARTS AND LABOUR BENCH WARRANTY

Within the warranty period, contact Omcan Inc. At 1-800-465-0234 to schedule a drop off to either an Omcan authorized service depot in the area, or to an Omcan Service warehouse to repair the equipment.

Unauthorized maintenance will void the warranty. Warranty covers electrical and part failures, not improper use.

Please see [www.omcan.com/warranty.html](http://www.omcan.com/warranty.html) for complete info.

### WARNING:

The packaging components (cardboard, polyethylene, and others) are classified as normal solid urban waste and can therefore be disposed of without difficulty.

In any case, for suitable recycling, we suggest disposing of the products separately (differentiated waste) according to the current norms.

**DO NOT DISCARD ANY PACKAGING MATERIALS IN THE ENVIRONMENT!**

# Technical Specifications

Model	SE-CN-0203	SE-CN-0305	SE-CN-0406	SE-CN-0508
Seal Bar Length	8" / 203mm	12" / 305mm	16" / 406mm	20" / 508mm
Electrical	110V/60/1			
Weight	5.3 lbs. / 2.4 kgs.	8.8 lbs. / 4 kgs.	10 lbs. / 4.5 kgs.	13 lbs. / 5.9 kgs.
Item Number	14446	14448	14450	14451

The unit features:

- Compact Design.
- Strong Water Tight Seal.

# Technical Specifications

- Fast Operation.
- Precise Electric Circuit.
- Long Lasting.

## MAIN COMPONENTS

- |                                       |                                     |
|---------------------------------------|-------------------------------------|
| 1. Handle Knob.                       | 12. Upper non-stick material Cloth. |
| 2. Platen Arm.                        | 13. Strain Relief Busing.           |
| 3. Platen Spring.                     | 14. Power Supply Cord.              |
| 4. Platen.                            | 15. Heating Element.                |
| 5. Silicon Rubber.                    | 16. Pilot Lamp.                     |
| 6. Swivel.                            | 17. Timer Knob.                     |
| 7. Hinge.                             | 18. Control Panel.                  |
| 8. Hinge Bracket.                     | 19. Variable Resistor.              |
| 9. Enclosure.                         | 20. Switch Level.                   |
| 10. Metal Plate.                      |                                     |
| 11. Lower Element non-stick material. |                                     |

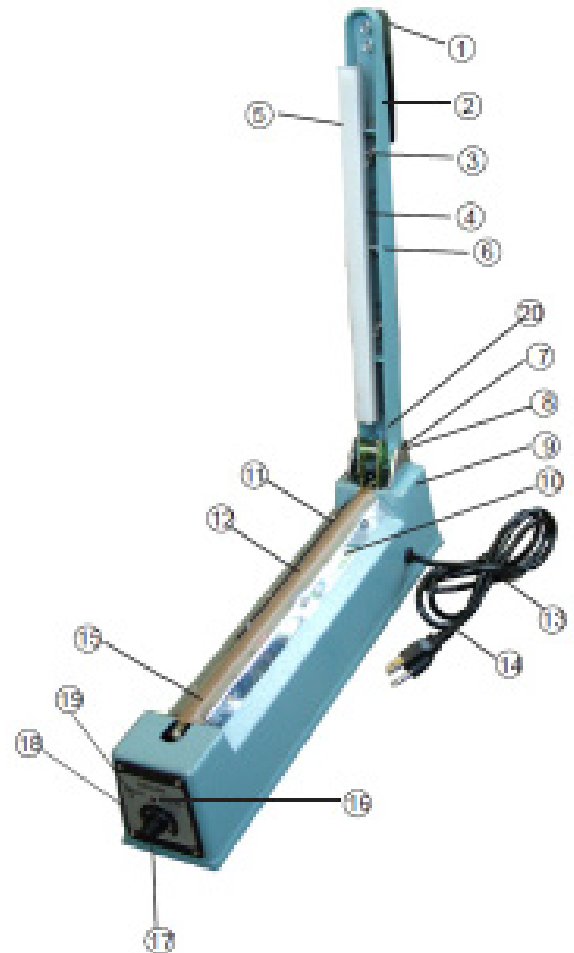

## Operation

1. Plug the cord into a grounded outlet. You do not need to switch the machine on. The machine will operate only when the arm is down. Control the timer according to the thickness of the material to be sealed. Use a higher setting for thicker material. Pull the handle down to seal. Sealing takes place when the light it on. Leave the arm down for an additional few seconds after the light turns off to obtain a better seal.
2. Use a lower setting if the seal burns through.
3. Raise to a higher setting if the seal is not tight enough.
4. Should the bag stick to the silicon rubber, you did not give it enough time to cool.
5. Once you set the time, there is no need to reset it as the machine will remain constant and unchanged.

## REFERENCE

Item Number	Model Number	Description	Manufacturer Model Number
14446	SE-CN-0203	Sealer Impulse 8" / 203mm Bar 110V/60/1	PFS-08
14448	SE-CN-0305	Sealer Impulse 12" 305mm Bar 110V/60/1	PFS-12
14450	SE-CN-0406	Sealer Impulse 16" 406mm Bar 110V/60/1	PFS-16
14451	SE-CN-0508	Sealer Impulse 20" 508mm Bar 110V/60/1	PFS-20

## Parts Breakdown

**Model SE-CN-0203** 14446

**Model SE-CN-0305** 14448

**Model SE-CN-0406** 14450

**Model SE-CN-0508** 14451

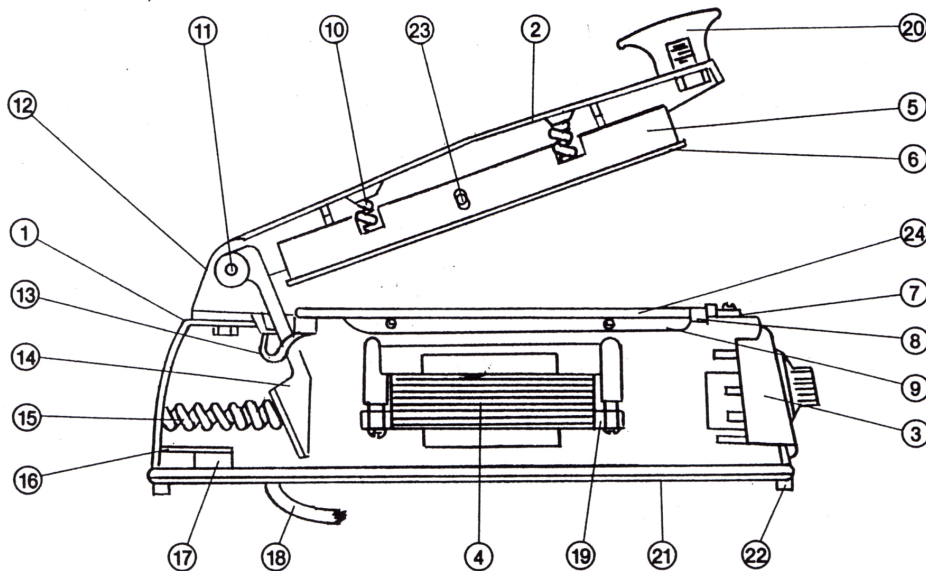

**ELEMENT SERVICE KIT** 25

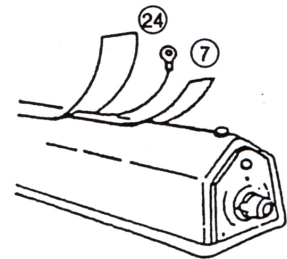

# Parts Breakdown

## Model SE-CN-0203 14446

Item No.	Description	Position	Item No.	Description	Position	Item No.	Description	Position
76813	Main Housing for PFS-08	01	19424	Spring for PFS-08	10	19426	Bracket for PFS-08	19
76814	Hand Lever for PFS-08	02	76816	Hand Lever Pin for PFS-08	11	76823	Lever Hand Knob for PFS-08	20
17736	Timer Assembly for PFS-08	03	76817	Hand Lever Bracket for PFS-08	12	76824	Bottom Plate Housing for PFS-08	21
19197	Transformer - 110V for PFS-08	04	76818	Tension Spring Element for PFS-08	13	16029	Rubber Foot for PFS-08	22
19422	Aluminum Bar for PFS-08	05	76819	Fulcrum Lever for PFS-08	14	76825	Pressure Bar Pin for PFS-08	23
19423	Rubber Seal for PFS-08	06	16028	Lever Hand Spring for PFS-08	15	19425	Teflon Strip for PFS-08	24
76815	Sealing Band Element Trim Wire Element for PFS-08	07	76820	Microswitch Bracket for PFS-08	16	16039	Element Service Kit for PFS-08	25
25192	Element Insulator for PFS-08	08	76821	Microswitch for PFS-08	17			
19428	Teflon Cover Plate for PFS-08	09	76822	Power with Plug Cord for PFS-08	18			

## Model SE-CN-0305 14448

Item No.	Description	Position	Item No.	Description	Position	Item No.	Description	Position
77319	Main Housing for PFS-12	01	19424	Spring for PFS-12	10	19426	Bracket for PFS-12	19
77320	Hand Lever for PFS-12	02	76816	Hand Lever Pin for PFS-12	11	16032	Lever Hand Knob for PFS-12	20
16030	Timer Assembly for PFS-12	03	76817	Hand Lever Bracket for PFS-12	12	64888	Bottom Plate Housing for PFS-12	21
19198	Transformer - 110V for PFS-12	04	76818	Tension Spring Element for PFS-12	13	16033	Rubber Foot for PFS-12	22
19421	Aluminum Bar for PFS-12	05	76819	Fulcrum Lever for PFS-12	14	76825	Pressure Bar Pin for PFS-12	23
21106	Rubber Seal for PFS-12	06	77321	Lever Hand Spring for PFS-12	15	77322	Teflon Strip for PFS-12	24
64151	Sealing Band Element Trim Wire Element for PFS-12	07	76820	Microswitch Bracket for PFS-12	16	16040	Element Service Kit for PFS-12	25
25192	Element Insulator for PFS-12	08	19430	Microswitch for PFS-12	17			
19427	Teflon Cover Plate for PFS-12	09	76822	Power with Plug Cord for PFS-12	18			





# Parts Breakdown

## Model SE-CN-0406 14450

Item No.	Description	Position	Item No.	Description	Position	Item No.	Description	Position
77323	Main Housing for PFS-16	01	19424	Spring for PFS-16	10	19426	Bracket for PFS-16	19
77324	Hand Lever for PFS-16	02	76816	Hand Lever Pin for PFS-16	11	77329	Lever Hand Knob for PFS-16	20
16037	Timer Assembly for PFS-16	03	76817	Hand Lever Bracket for PFS-16	12	64889	Bottom Plate Housing for PFS-16	21
19199	Transformer - 110V for PFS-16	04	76818	Tension Spring Element for PFS-16	13	77330	Rubber Foot for PFS-16	22
21102	Aluminum Bar for PFS-16	05	76819	Fulcrum Lever for PFS-16	14	76825	Pressure Bar Pin for PFS-16	23
77325	Rubber Seal for PFS-16	06	77327	Lever Hand Spring for PFS-16	15	77331	Teflon Strip for PFS-16	24
64152	Sealing Band Element Trim Wire Element for PFS-16	07	76820	Microswitch Bracket for PFS-16	16	16041	Element Service Kit for PFS-16	25
25192	Element Insulator for PFS-16	08	77328	Microswitch for PFS-16	17			
77326	Teflon Cover Plate for PFS-16	09	76822	Power with Plug Cord for PFS-16	18			

## Model SE-CN-0508 14451

Item No.	Description	Position	Item No.	Description	Position	Item No.	Description	Position
77332	Main Housing for PFS-20	01	19424	Spring for PFS-20	10	19426	Bracket for PFS-20	19
77333	Hand Lever for PFS-20	02	76816	Hand Lever Pin for PFS-20	11	77339	Lever Hand Knob for PFS-20	20
16038	Timer Assembly for PFS-20	03	76817	Hand Lever Bracket for PFS-20	12	64890	Bottom Plate Housing for PFS-20	21
19200	Transformer - 110V for PFS-20	04	76818	Tension Spring Element for PFS-20	13	77340	Rubber Foot for PFS-20	22
77334	Aluminum Bar for PFS-20	05	76819	Fulcrum Lever for PFS-20	14	76825	Pressure Bar Pin for PFS-20	23
77335	Rubber Seal for PFS-20	06	77337	Lever Hand Spring for PFS-20	15	77341	Teflon Strip for PFS-20	24
64153	Sealing Band Element Trim Wire Element for PFS-20	07	76820	Microswitch Bracket for PFS-20	16	16042	Element Service Kit for PFS-20	25
25192	Element Insulator for PFS-20	08	77338	Microswitch for PFS-20	17			
77336	Teflon Cover Plate for PFS-20	09	76822	Power with Plug Cord for PFS-20	18			

# Electrical Schematics

**Model SE-CN-0203** 14446

**Model SE-CN-0305** 14448

**Model SE-CN-0406** 14450

**Model SE-CN-0508** 14451

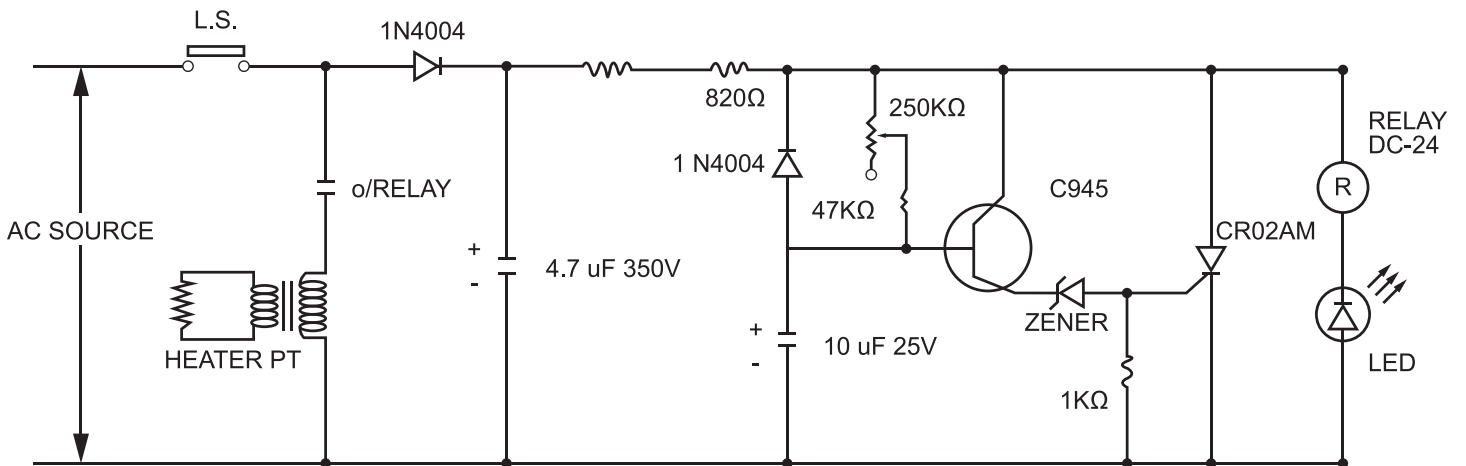



# Warranty Registration

Thank you for purchasing an Omcan product. To register your warranty for this product, complete the information below, tear off the card at the perforation and then send to the address specified below. You can also register online by visiting:

Merci d'avoir acheté un produit Omcan. Pour enregistrer votre garantie pour ce produit, complétez les informations ci-dessous, détachez la carte au niveau de la perforation, puis l'envoyer à l'adresse spécifiée ci-dessous. Vous pouvez également vous inscrire en ligne en visitant:

Gracias por comprar un producto Omcan usted. Para registrar su garantía para este producto, complete la información a continuación, cortar la tarjeta en la perforación y luego enviarlo a la dirección indicada a continuación. También puede registrarse en línea en:

[www.omcan.com/warrantyregistration.html](http://www.omcan.com/warrantyregistration.html)

For mailing in Canada

Pour postale au Canada

Por correo en Canadá

**OMCAN**

PRODUCT WARRANTY REGISTRATION

3115 Pepper Mill Court,

Mississauga, Ontario

Canada, L5L 4X5

For mailing in the US

Pour diffusion aux États-Unis

Por correo en los EE.UU.

**OMCAN**

PRODUCT WARRANTY REGISTRATION

4450 Witmer Industrial Estates, Unit 4,

Niagara Falls, New York

USA, 14305

*or email to: [service@omcan.com](mailto:service@omcan.com)*



Purchaser's Information

Name: \_\_\_\_\_

Address: \_\_\_\_\_

City: \_\_\_\_\_ Province or State: \_\_\_\_\_ Postal or Zip: \_\_\_\_\_

Country: \_\_\_\_\_

Dealer from which Purchased: \_\_\_\_\_

Dealer City: \_\_\_\_\_ Dealer Province or State: \_\_\_\_\_

Invoice: \_\_\_\_\_

Model Name: \_\_\_\_\_ Model Number: \_\_\_\_\_

Machine Description: \_\_\_\_\_

Date of Purchase (MM/DD/YYYY): \_\_\_\_\_

Would you like to extend the warranty?  Yes  No

Company Name: \_\_\_\_\_

Telephone: \_\_\_\_\_

Email Address: \_\_\_\_\_

Type of Company:

Restaurant  Bakery  Deli

Butcher  Supermarket  Caterer

Institution (*specify*): \_\_\_\_\_

Other (*specify*): \_\_\_\_\_

Serial Number: \_\_\_\_\_

Date of Installation (MM/DD/YYYY): \_\_\_\_\_

**Thank you for choosing Omcan | Merci d'avoir choisi Omcan | Gracias por elegir Omcan**



Since 1951 Omcan has grown to become a leading distributor of equipment and supplies to the North American food service industry. Our success over these many years can be attributed to our commitment to strengthen and develop new and existing relationships with our valued customers and manufacturers. Today with partners in North America, Europe, Asia and South America, we continually work to improve and grow the company. We strive to offer customers exceptional value through our qualified local sales and service representatives who provide convenient access to over 3,500 globally sourced products.

---

Depuis 1951 Omcan a grandi pour devenir un des “leaders” de la distribution des équipements et matériel pour l’industrie des services alimentaires en Amérique du Nord. Notre succès au cours de ces nombreuses années peut être attribué à notre engagement à renforcer et à développer de nouvelles et existantes relations avec nos clients et les fabricants de valeur. Aujourd’hui avec des partenaires en Amérique du Nord, Europe, Asie et Amérique du Sud, nous travaillons continuellement à améliorer et développer l’entreprise. Nous nous efforçons d’offrir à nos clients une valeur exceptionnelle grâce à nos ventes locales qualifiées et des représentants de service qui offrent un accès facile à plus de 3500 produits provenant du monde entier.

---

Desde 1951 Omcan ha crecido hasta convertirse en un líder en la distribución de equipos y suministros de alimentos en América del Norte industria de servicios. Nuestro éxito en estos años se puede atribuir a nuestro compromiso de fortalecer y desarrollar nuevas relaciones existentes con nuestros valiosos clientes y fabricantes. Hoy con socios de América del Norte, Europa, Asia y América del Sur, que trabajan continuamente para mejorar y crecer la empresa. Nos esforzamos por ofrecer a nuestros clientes valor excepcional a través de nuestro local de ventas y representantes de los servicios que proporcionan un fácil acceso a más de 3,500 productos con origen a nivel mundial.

