



User Manual

Mytee Lite™

Model: 8030, 8070

REV: 4/24/20

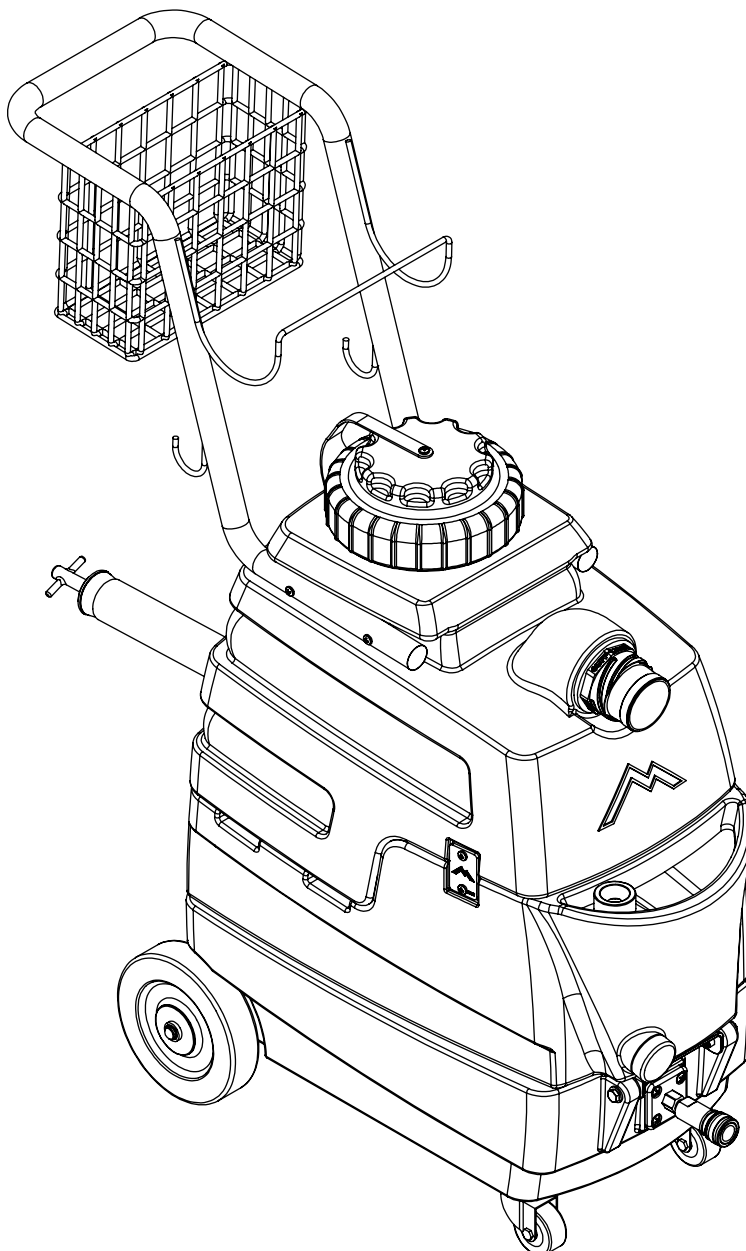

13655 Stowe Dr. Poway, CA 92064

P: (858) 679-1191

F: (858) 726-6005

www.mytee.com

Dear Customer:

Congratulations on the purchase of your new Mytee Lite™ Carpet & Upholstery Spotter.

As technology continues to develop you can work confidently knowing that both Mytee Products and its employees are equally dedicated to developing with the industry and its advances.

Like any other piece of machinery or technology, the Mytee Lite™ also requires the proper maintenance and care to keep the product working over extended use. Neglecting your machine, abusing it or not operating it properly can void its warranty and prevent the machine from performing to the quality and standard you'd expect out of the Mytee Products line.

If you have any warranty concerns or questions, please review this manual thoroughly or do not hesitate to contact your distributor. If there are questions regarding maintenance, replacement, or ordering parts please contact an authorized Mytee Products Service Center. To see an updated list please visit our website at <http://www.mytee.com/support/service-centers>.

Before using your Mytee product, please read this manual thoroughly.

Sincerely,

Mytee Customer Care Dept.

	Important Safety Information.....	4
1	At a Glance.....	6
	1.1 - Technical Specifications.....	6
	1.2 - Included with the Mytee Lite™.....	6
	1.3 - Mytee Lite™ Front View.....	7
	1.4 - Mytee Lite™ Rear View.....	8
	1.5 - Switch Plate.....	9
2	Machine Operation.....	10
	2.1 - Powering the Mytee Lite™.....	10
	2.2 - Connecting Hoses & Cleaning Tools.....	10
	2.3 - Filling the Solution Tank.....	10
	2.4 - Operating the Mytee Lite™.....	11
	2.5 - Emptying the Solution & Recovery Tanks.....	11
3	Machine Maintenance.....	12
	3.1 - Filter Maintenance.....	12
	3.2 - System Maintainer.....	12
4	Available Accessories.....	13
5	Troubleshooting.....	14

Important Safety Information

Grounding Instructions

This machine must be grounded. If it should malfunction or breakdown, grounding provides a path of least resistance for electrical shock. This machine is equipped with a cord having an equipment-grounding conductor and grounding plug. The plug must be plugged into an appropriate outlet that is properly installed in accordance with all local code and ordinances. Do not remove ground pin; if missing, replace plug before use.



Improper installation of the equipment-grounding conductor can result in a risk of electric shock. Be sure to check with a qualified electrician or service person if you are in doubt as to whether the outlet is properly grounded. If the plug will not fit in the outlet do not modify either the plug nor the machine's cord, instead have a proper outlet installed by a qualified technician.

This machine is for use on a nominal 120-volt circuit and with a grounding plug similar to the one in Figure 1 below. If a proper outlet is not available, follow the illustrations of Figure 2 & 3 to install a temporary-grounding plug. This temporary work-around should be used only until a proper outlet (Figure 1) can be installed by a qualified electrician. When and if this type of adapter is employed, screw the adapter's extended tab into place with a metal screw. However, grounding adapters are not approved for use in Canada.

Again, be sure to check the grounding pin for damages and replace if necessary.

The Green, or Green-Yellow, wire in the cord is the grounding wire. When replacing a plug, this wire must be attached to only the grounding pin.

DO NOT use extension cords.

Please Note for America use only.

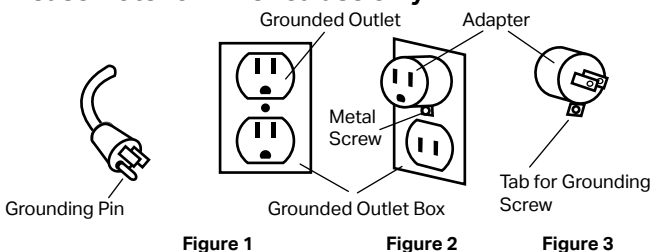

Parts and Service

Please contact a Mytee service personnel or Mytee authorized Service Center using Mytee original replacement parts and accessories for repairs are needing to be performed. When and if calling Mytee for support, please have your Model and Serial Number available for faster assistance.

Name Plate

The Model and Serial Number are located on the lower half of the back of the machine near the power plugs and will be required for ordering replacement parts. You can use the space provided on the front of this manual to note down both for future referencing.

Unpacking the Machine

When your new machine is delivered, please carefully inspect both the shipping carton and the machine for damages. If damage is evident, save both the shipping carton and machine so that the delivering carrier can inspect it. Contact the carrier immediately to file a freight claim if there has been any damage.

Caution and Warnings

Symbols

Mytee uses the symbols below to signal potentially dangerous conditions. Always read this information carefully and take the necessary steps to protect personnel and property.



Is used to warn of immediate hazards that will cause se-



vere personal injury or death.

Is used to call attention to a situation that could cause



severe personal injury.

Is used to call attention to a situation that could cause minor personal injury or damage to the machine or other property. When using an electrical appliance, basic pre-

cautions should always be followed, including the following: Read all instructions before using this machine. This product is intended for commercial use only.

To reduce the risk of fire, electrical shock, or injury:

1. Read all instructions before using equipment.
2. Use only as described in this manual. Use only manufacturer's recommended attachments.
3. Always unplug power cord from electrical outlet before attempting any adjustments or repairs.
4. Do not unplug by pulling on cord. To unplug, grasp the plug, not the cord.
5. Do not pull or carry by cord. Do not close a door on cord or pull cord around sharp edges or corners.
6. Do not run appliance over cord. Keep cord away from heated surfaces.
7. Do not use with damaged cord or plug. If cord is damaged, repair immediately.
8. Do not use outdoors or on wet surfaces and or standing water.
9. Always unplug or disconnect the appliance from power supply when not in use.
10. Do not allow to be used as a toy. Close attention is necessary when used by or near children.
11. Do not use in areas where flammable or combustible material may be present.
12. Do not leave the unit exposed to harsh weather elements. Temperatures below freezing may damage components and void warranty.
13. Use only the appropriate handles to move and lift unit. Do not use any other parts of this machine for this purpose.
14. Do not pull on hoses in order to move the unit. Only use the appropriate handles.
15. Keep hair, loose clothing, fingers, and all parts of the body away from all openings and moving parts.
16. Use extra care when using on stairs.
17. To reduce the risk of fire or electric shock, do not use this machine with a solid-state speed control device.
18. The voltage and frequency indicated on the name

plate must correspond to the wall receptacle supply voltage.

19. When cleaning and servicing the machine, local or national regulations may apply to the safe disposal of liquids which may contain: chemicals, grease, oil, acid, alkalines, or other dangerous liquids.

20. Do not leave operating unattended.

1 - At a Glance

1.1 - Technical Specifications

8030 Mytee Lite™

Solution Tank	4 Gallons
Recovery Tank	4 Gallons
Vacuum	Single 3-Stage
CFM	100
Water Lift	130"
Pump PSI	55
Pump GPM	0.37
Power Consumption	11 amps @ 115V
Machine Weight	43 lbs.
Machine Dimensions	With handle: 33" x 12" x 36.5" Without handle: 18" x 12" x 28.5"
Power Cord	Single 25' 12/3

8070 Mytee Lite™

Solution Tank	4 Gallons
Recovery Tank	4 Gallons
Vacuum	Single 3-Stage
CFM	100
Water Lift	130"
Pump PSI	120
Pump GPM	1.3
Heater	1,000 watt, 210°F max.
Power Consumption	19 amps @ 115V
Machine Weight	48 lbs.
Machine Dimensions	With handle: 33" x 12" x 36.5" Without handle: 18" x 12" x 28.5"
Power Cord	Single 25' 12/3

1.2 - Included with the Mytee Lite™

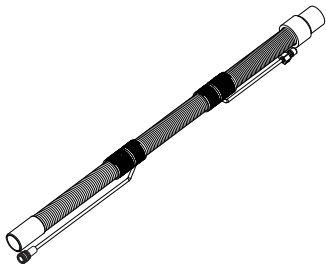

8501 15' x 1.25" Vacuum & Solution Hose

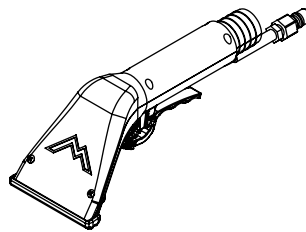

8400P 4" Air Lite™ Upholstery Tool

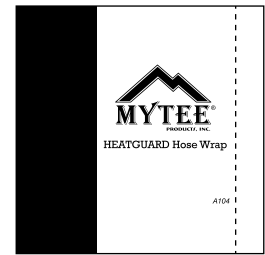

Heatguard™ Hose Wrap



Easy-Push Handle

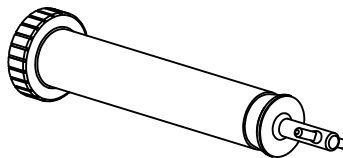

A110 Drain Hose

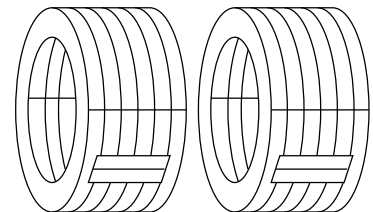

P590 Cuties™ Pack of 2 QD Safety Covers (included w/ 8070)

1.3 - Mytee Lite™ Front View

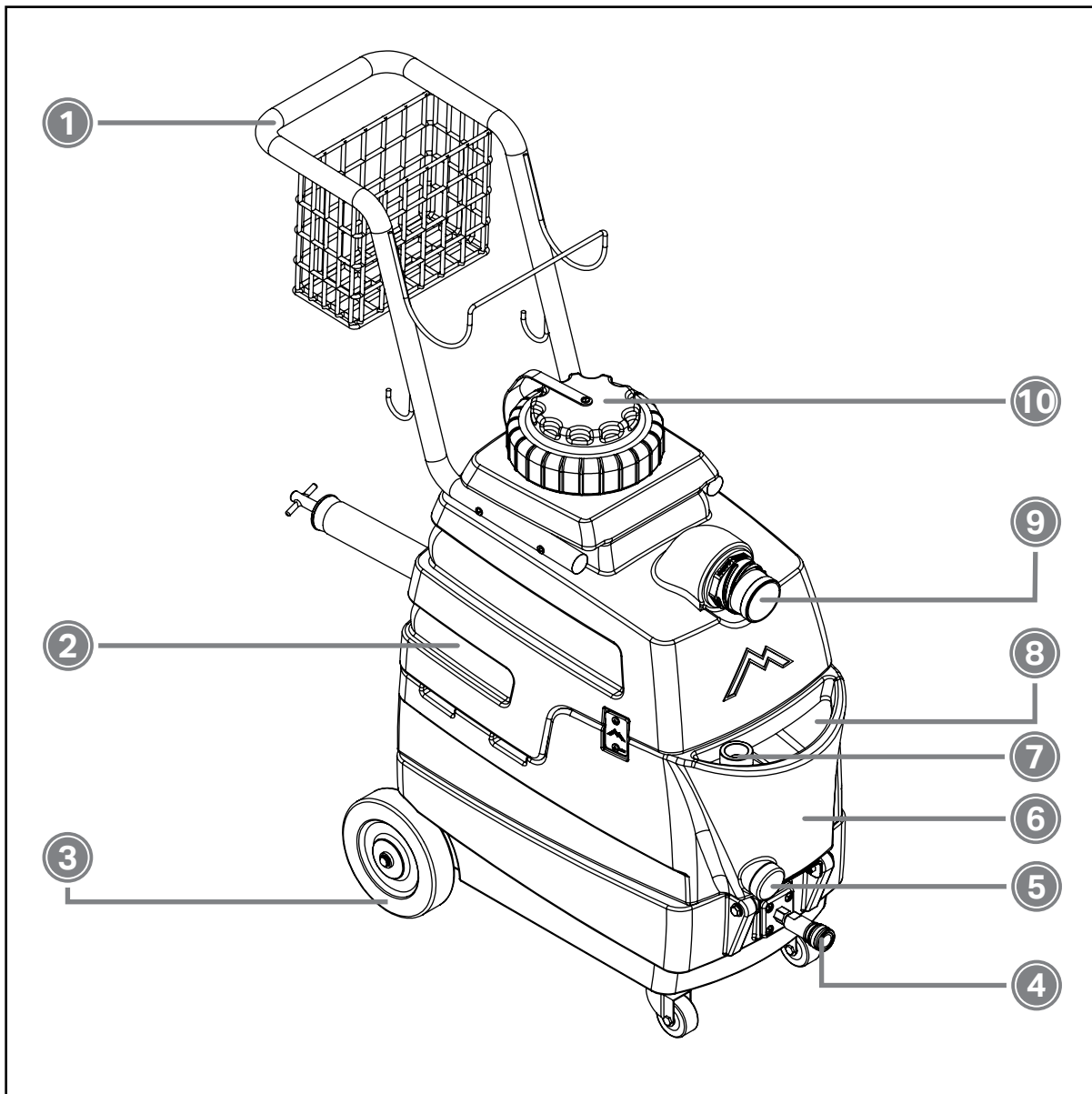

- 1. Easy-Push Handle
- 2. Recovery Tank
- 3. 10" Wheels
- 4. Quick Disconnect
- 5. Solution Tank Drain

- 6. Solution Tank
- 7. Faucet Fill Hose
- 8. Bucket Fill Opening
- 9. Cuff-Lynx™ Hose Connection
- 10. Recovery Tank Lid

1 - At a Glance

1.4 - Mytee Lite™ Rear View

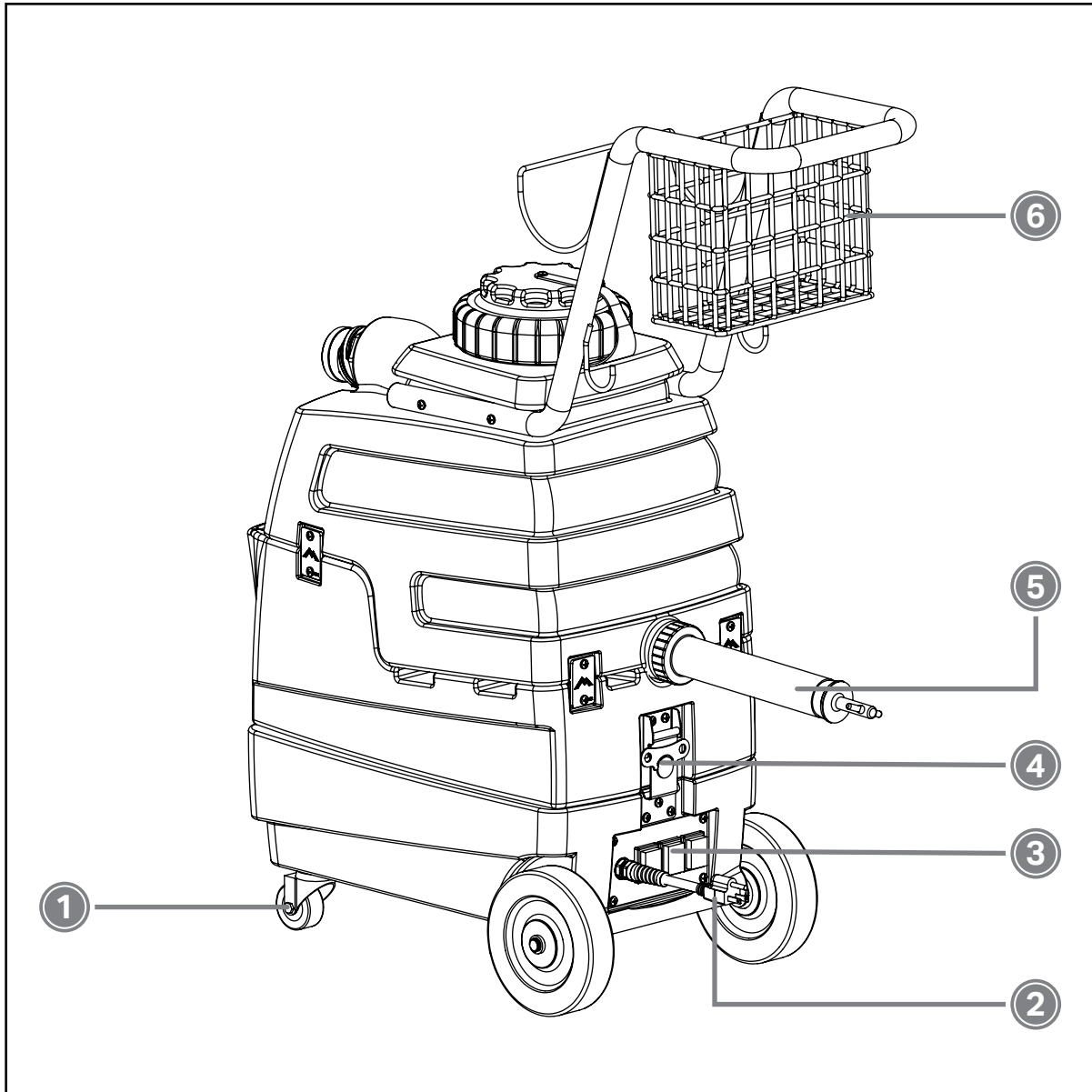

1. 3" Locking Front Casters
2. 25' 12/3 Power Cord
3. Switch Plate
4. Opening Latch
5. Recovery Tank Drain Hose
6. Storage Basket

1.5 - Switch Plate

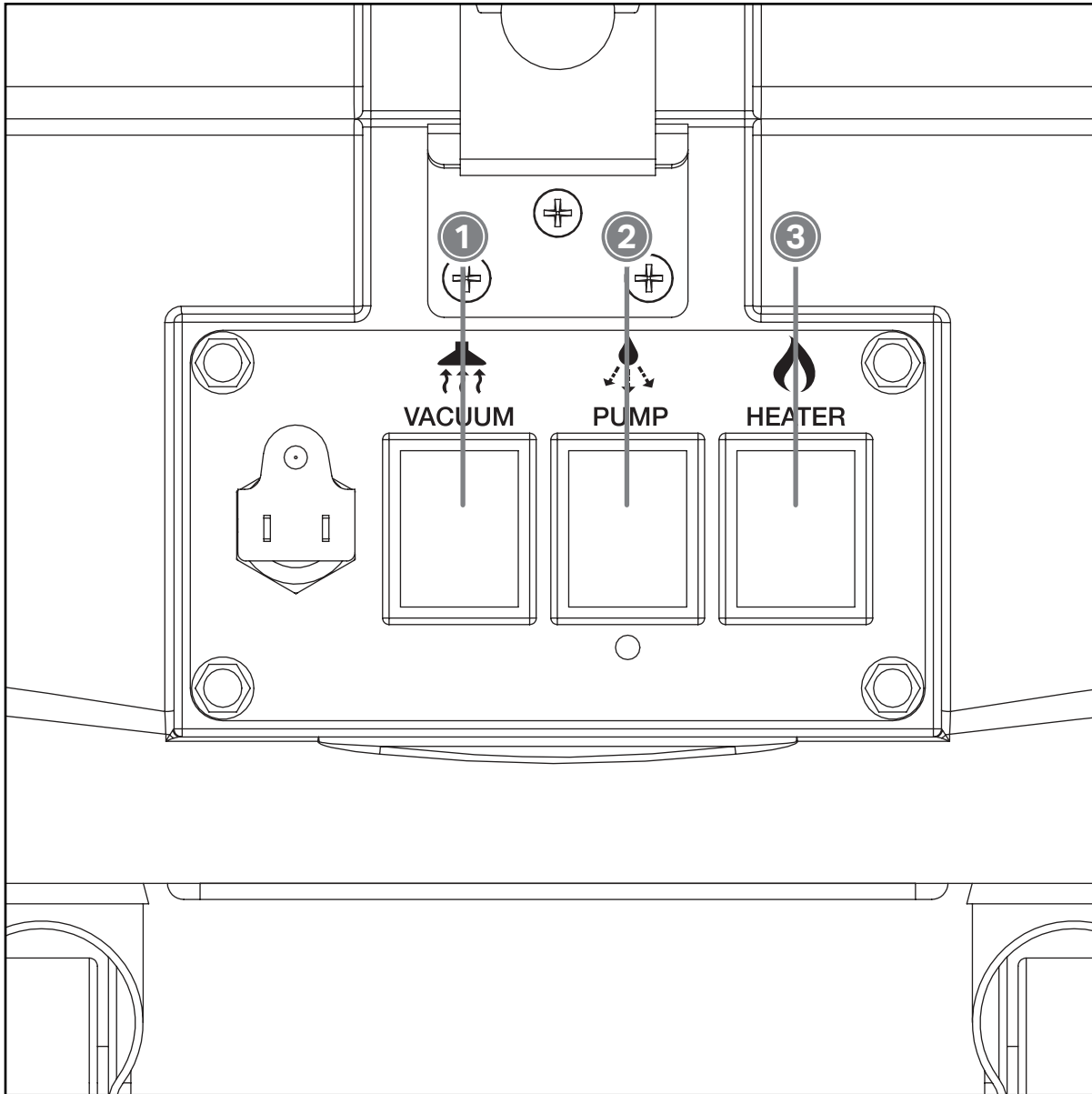

1. Vacuum Switch

Activates the vacuum motor.

2. Pump Switch

Activates the solution pump.

3. Heater Switch

Activates the heater (8070 model).

2 - Machine Operation

2.1 - Installing the Handle

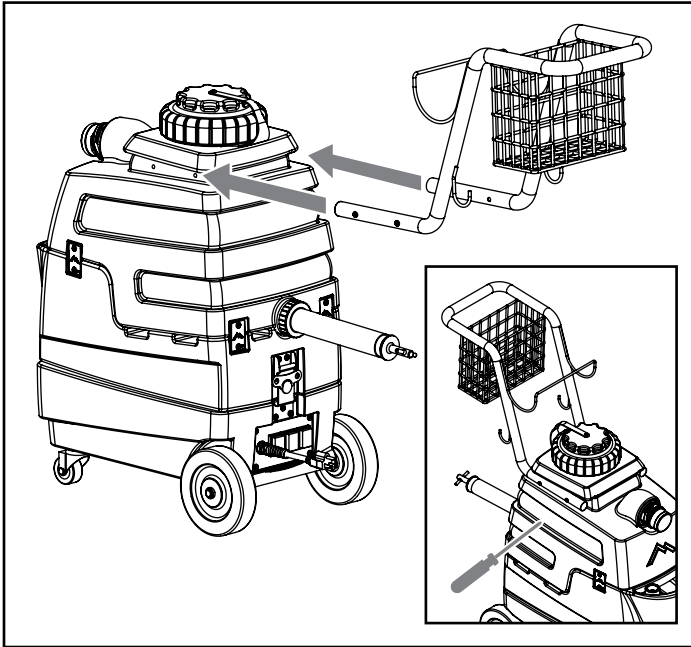

Slide the handle into position and line up the holes with the threaded inserts on the Mytee Lite™. Thread screws into the front two holes by hand first, and then the back two. Tighten all the screws in an X pattern with a screwdriver. ♦

2.1 - Powering the Mytee Lite™

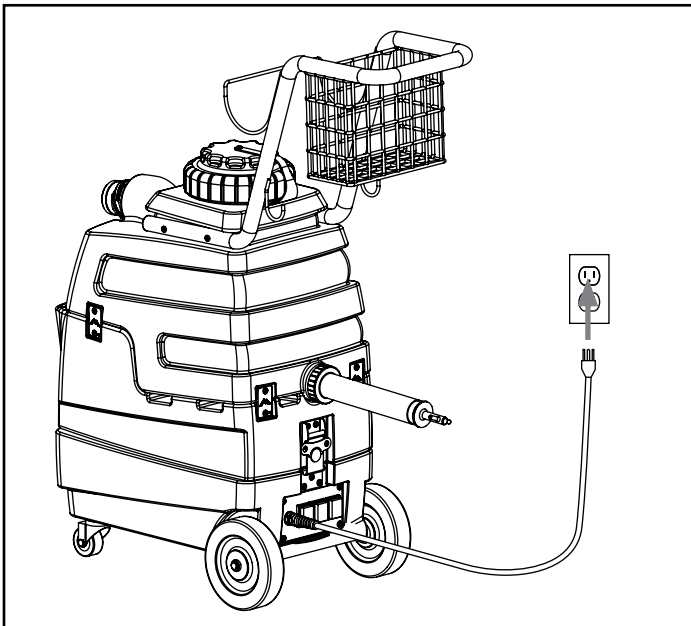

To power the Mytee Lite™, plug the power cord into a

grounded 20 amp outlet. ♦

2.2 - Connecting Hoses & Cleaning Tools

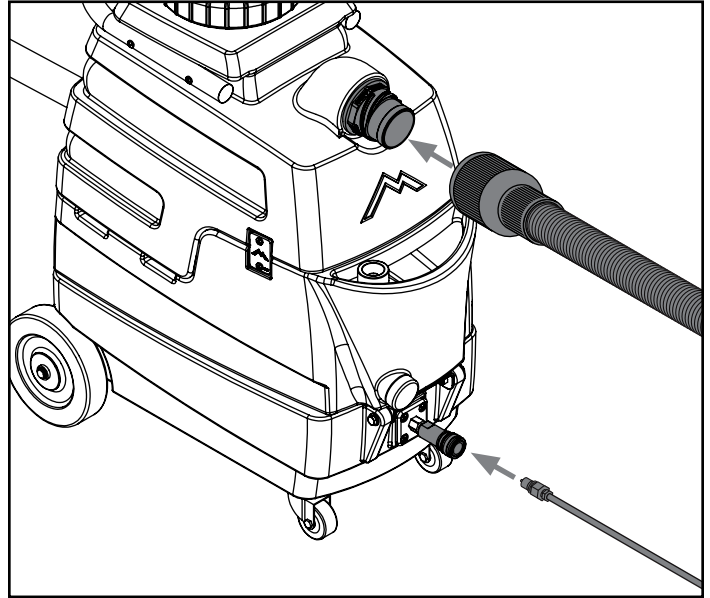

Vacuum & Solution Hoses

The Mytee Lite™ features a 2" Cuff-Lynx™ vacuum hose connection as well as a standard 1/4" quick disconnect fitting for solution hoses.

IMPORTANT: Do not pull on hoses in order to move the unit. Only use the appropriate handles. ♦

2 - Machine Operation

2.3 - Filling the Solution Tank

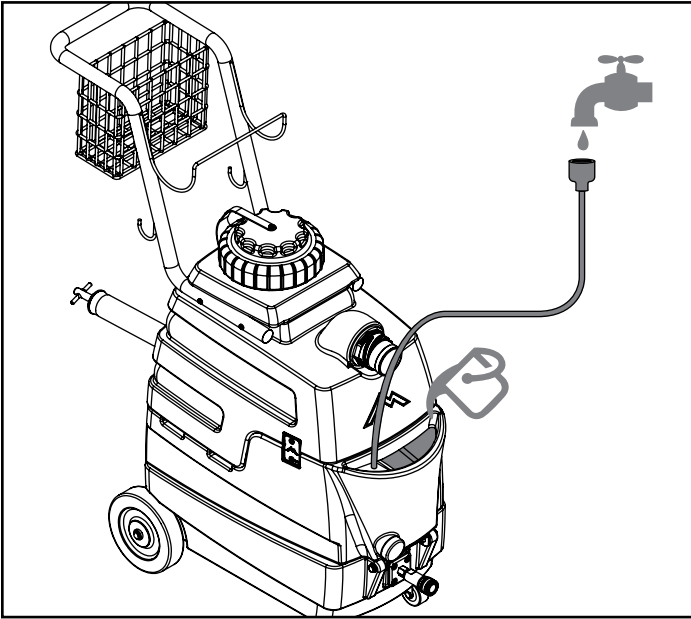

The Mytee Lite™ solution tank can be filled up via the faucet fill hose or from a bucket via the opening. ♦

2.4 - Operating the Mytee Lite™

Switching On The Unit

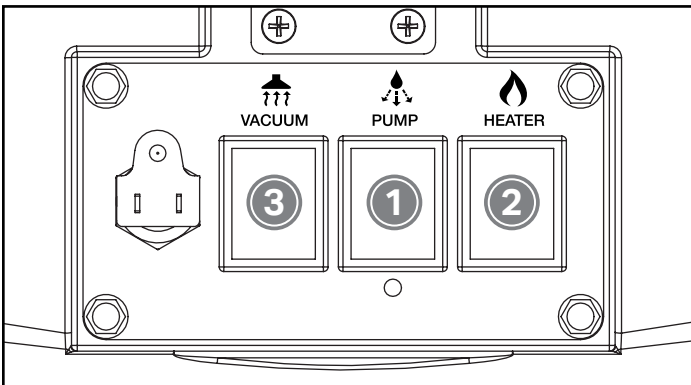

In order to avoid vapor locking the unit, the Mytee Lite's™ components should be switched on by following the procedure below:

1. Turn pump switch on.
2. Pull the lever on the cleaning tool to release air in the line. Hold lever until a steady flow of water comes out of the wand.
3. Once pump is primed and there is pressure in the solu-

tion line, turn on heater switch and wait a few minutes for water to heat up.

4. Once water is heated, turn on vacuum and begin cleaning.

Note: When cleaning upholstery, always check manufacturer's cleaning instructions.

Cleaning With The Mytee Lite™

For best results when extracting, do one wet pass followed by two dry passes. This ensures you're not over-soaking the material and also gives the heater time to catch up. ♦

2.5 - Emptying the Solution & Recovery Tanks

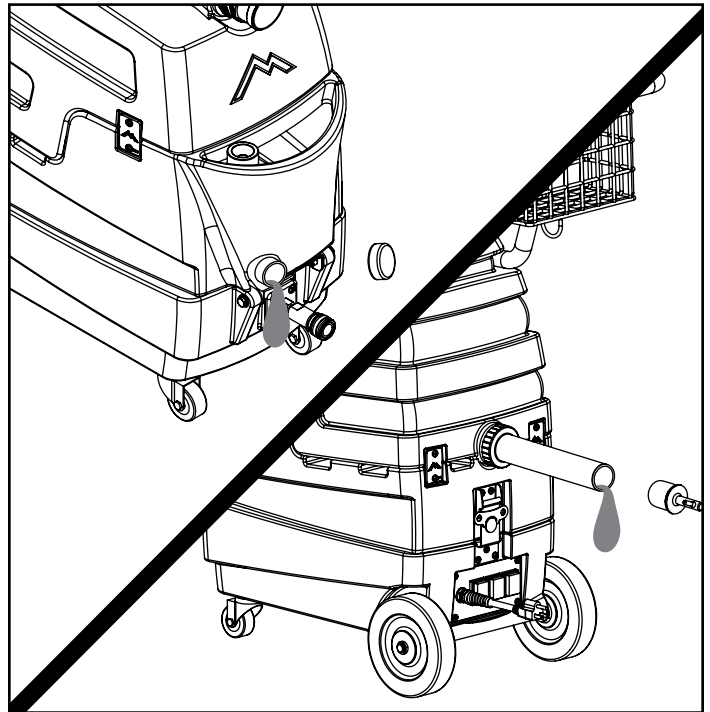

The solution tank drain is located on the front, lower left corner of the solution tank.

The recovery tank drain is located on the back of the machine at the bottom of the recovery tank. Attach the included recovery tank drain hose in order to easily empty into a bucket or other receptacle. ♦

3 - Machine Maintenance

In order to keep the Mytee Lite™ running smoothly and reduce the risk of damage to the machine and subsequent downtime, Mytee recommends following the maintenance schedule below:

Maintenance Item	Daily	Weekly
Clean and inspect tanks.	X	
Clean and inspect hoses.	X	
Check and clean internal filters.	X	
Check power supply cable.	X	
Clean machine with all-purpose cleaner and cloth.	X	
Check spray nozzles.	X	
Flush solution system with Mytee System Maintainer.		X
Inspect vacuum hoses for holes and loose cuffs.		X
Inspect spray pattern for clogging. If clogged, remove spray tips and soak them in a recommended liquid neutralizer for up to six hours. To remove spray tip, twist spray tip body counter-clockwise.		X
Lubricate wheels with water resistant oil.		X
Inspect machine for water leaks and loose hardware.		X

How to use System Maintainer:

1. Mix 1-quart 3601 System Maintainer with 1-quart of warm water.
2. After thoroughly mixing, pour this solution into the solution tank.
3. Turn the pump on **FIRST**, and run solution through your cleaning tool. **NOTE:** The jet should be removed from the cleaning tool in order to prevent clogging due to loosening of deposits in line.
4. Next, turn on the heater. If the heater is turned on first, it will result in a vapor lock, which will affect the machine's operation.
5. Next, with both the pump and heater on, begin running the solution through the machine. This allows the solution to break down any build up in the lines.
6. After running all of the solution through the machine, fill the tank with clean, warm water. Run the water through the machine to clear the solution completely out of the tank & lines. ♦

3.1 - Filter Maintenance

The Mytee Lite™ has a small filter on the top of the vacuum stack in the recovery tank. This filter should be checked and cleaned after each use. ♦

3.2 - System Maintainer

Weekly flushing of the solution system with Mytee® System Maintainer helps keep lines clean and prevents chemical build-up, improving pump life, performance and pressure.

4 - Available Accessories

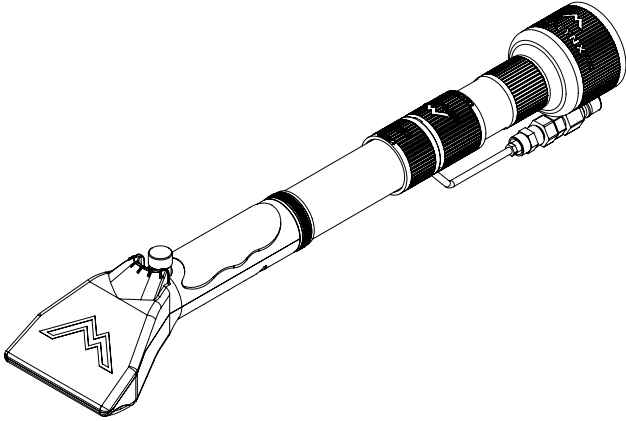

8400DX Mytee Dry™ Upholstery Tool

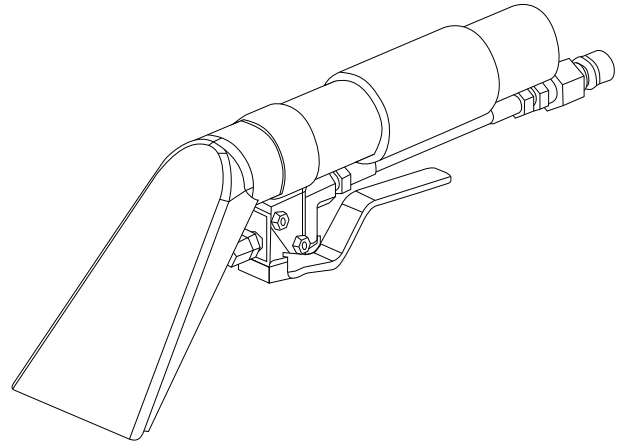

8400 4" Stainless Steel Upholstery Tool

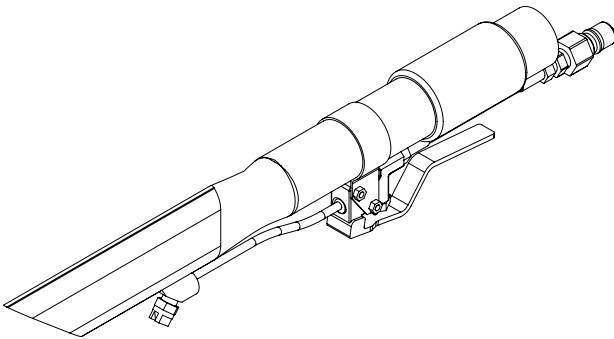

8700 Crevice Tool

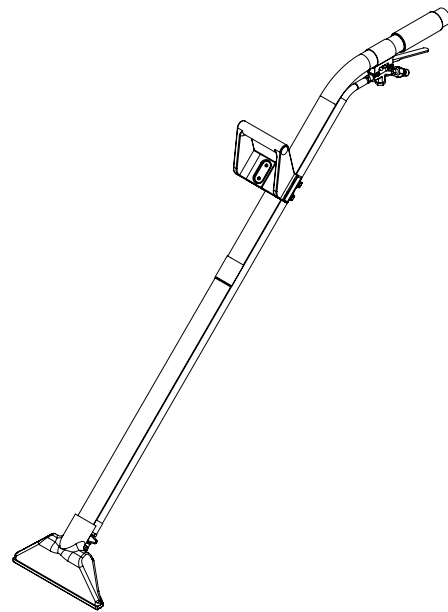

8390EZ 10" Single Jet Carpet Cleaning Wand

5 - Troubleshooting

5.1 - Vacuum Troubleshooting

Vacuum is not turning on.	
Possible Cause	Solution
Vacuum may not be getting power.	<p>Check the electrical connections and the switch. Look for loose or damaged wires.</p> <p>To check the switch:</p> <p>Unbolt the switch plate. Take a picture of the layout of the wires or tagging the wires for future reference. Switch the wires from the vacuum switch with the wires from either the pump or heater switch. Turn on the pump or heater switch (whichever one you exchanged wires with). If the vacuum turns on, then you know the vacuum switch is bad.</p>

Vacuum is not producing suction.	
Possible Causes	Solutions
Recovery tank is full.	Empty the recovery tank.
If the vacuum exhausts but there is no suction, then the hose from the recovery tank to the vacuum motor is disconnected.	Open the machine and find the hose running from the recovery tank to the vacuum motor. Check if it is disconnected. If so, reconnect it. If it has a leak, replace the hose (Part # PH627 if 1.5", PH628 if 2").
Vacuum hose blockage (if there is no suction or exhaust).	Check for blockage in the hose, starting from the cleaning tool to the machine.
Clogged filter in vacuum tank.	Clean out filter regularly.
Drain valve/cap is loose and is causing air leakage.	Tighten the drain valve/cap.

Hose cuffs are loose and causing air leakage.	Tighten all hose cuffs regularly as may loosen over time. Use a glue to prevent cuffs from coming loose (optional).
Lid on tank is loose and is causing air leakage.	Make sure the lid is tight.

Vacuum blows water out the exhaust.	
Possible Causes	Solutions
Foam building up in the recovery tank.	Use a defoaming solution in the recovery tank.

There is a loud grinding noise coming from the vacuum.	
Possible Cause	Solution
Debris has been sucked into the vacuum motor chamber. Usually results from dry vacuuming.	Replace the vacuum motor. To avoid repeat problem, DO NOT dry vacuum with your extractor.

[Click here](#) for more detailed information.

5 - Troubleshooting

5.2 - Pump Troubleshooting

Pump doesn't turn on.	
Possible Causes	Solutions
Bad switch at control panel.	Unbolt the switch plate. We recommend taking a picture of the layout of the wires or tagging the wires for future reference. Switch the wires from the pump switch with the wires from either the vacuum or heater switch. Turn on the vacuum or heater switch (whichever one you exchanged wires with). If the pump turns on, the pump switch is bad.
Loose or disconnected wire.	Disconnect the power cord from the electrical outlet. Open up the machine and look for any loose or disconnected wires. Re-attach or replace wires.

Pump runs but there is no spray.	
Possible Causes	Solutions
Blockage or kink somewhere in the line.	See chart on page 4 of the Diaphragm Pump Troubleshooting Guide to diagnose the location of the blockage.
Air is in the pump.	Prime the pump. Remove QD off the machine and solution hose. Make sure that the three-prong clip on the inside of the threaded end is evenly aligned below the thread of the QD.

Pump runs but there is no spray.	
Possible Causes	Solutions
On a new unit, the check valve between the pump and heater may hang up, causing the flow of water to be impeded or stop entirely.	Remove the check valve temporarily and check to see if the pump will flow water out of the pump outlet hose when the pump is turned on for a brief instant in order to verify cause. The remedy is to install a new check valve. Observe the proper orientation (flow direction) of the check valve. Tip: the check valve may be able to be temporarily returned to service by un-sticking the check valve poppet with manipulation of the poppet ball with a thin tool, like a straightened paperclip. Replace the check valve in unit assembly. NEVER OPERATE A UNIT WITHOUT A CHECK VALVE IN PLACE.

Pump runs for a second then shuts down.	
Possible Causes	Solutions
QD is pressure locked.	Relieve pressure from behind the QD by pressing in the button inside the QD.

Low PSI.	
Possible Causes	Solutions
The jet nozzle could be too large.	Replace the jet with one that has a smaller opening.

5 - Troubleshooting

Pump doesn't stop running.	
Possible Causes	Solutions
Leak somewhere in the line.	Disconnect the solution hose from the machine. If this causes the pump to stop running then the problem is outside the machine, either in the solution hose or tool. If it continues running on, open the machine and check for leaks. Repair the leak. If there are no leaks, run Mytee's System Maintainer™ (Part # 3601) through the machine to clear blockages.
Cracks or vacuum leaks on inlet side of pump.	Make sure hoses are secured tightly. If the inlet side of the pump is cracked or damaged, replace the pump.
Seals have been degraded by chemical.	Install seal repair kit.
Debris blocking inlet filter or pump head.	Clean filter and/or pump head.

Pump trips circuit breaker when turned on.	
Possible Causes	Solutions
Short in power switch.	Test by swapping vacuum and pump switch. If problem resolves, but vacuum begins tripping breaker, replace switch (Part #E515).
Short in electrical harness.	Risk of electric shock. Do this at your own risk. Remove pump from circuit by attaching power leads together. If breaker still pops when switch is toggled, then there is a short to the ground in the circuit. Replace wires as needed.

Short in pump motor.	If switch and harness check is OK, the short may be in the pump motor. Replace pump.
----------------------	--

[Click here](#) for more detailed information.

5.3 - Heater Troubleshooting

Heater is not heating water.	
Possible Causes	Solutions
Loose electrical connection.	Check all electrical connections, including power cord and harness.
Automatic sensor has failed, causing manual sensor to trip.	Reset the manual sensor button by pressing the small white and yellow button in the center of the sensor. If this works, but heater continues to trip the manual sensor, replace the automatic sensor (Part #E573) on the heater.
Heater element has failed.	Check for continuity through the element by reading the amperage. If amps are low, only part of the element may be heating up – in this case, the element is damaged and needs to be replaced.
Bad power switch.	If the element, sensors, and wiring all check out okay, there may be a bad switch on the switch-plate.

Running out of hot water too fast.	
Possible Causes	Solutions
Too much water flowing through the heater.	Remember, when using your machine, it is recommended you do one wet pass followed by two dry passes. This way you are not spraying as much and the hot water will last longer.
Jets being used are too large.	If your machine has a 1,000W or 1,200W heating system, make sure your cleaning tool has 0.02 jets.
Water in tank is very cold.	If possible, fill your solution tank with warm water in order to shorten the amount of time it takes for the water to heat up. The pumps are usually rated for 140°F water.
Heater has hard water buildup inside, leading to lost efficiency.	Run Mytee System Maintainer™ (Part # 3601) through the machine regularly in order to clear hard water or chemical residue that can block water flow and reduce heating ability. See product label for instructions.

Unit has vapor locked and there is no water pumping out of the unit.	
Possible Cause	Solution
Turning on the heater before turning on the pump and priming the unit.	Turn off the heater and allow the unit to cool completely. When machine has cooled, turn on the pump first. Prime the unit by spraying solution out of the cleaning tool. Then, turn on the heater.

[Click here](#) for more detailed information.

NOTES



Mytee Products, Inc.

13655 Stowe Dr.
Poway, CA 92064

www.mytee.com

© 2020 Mytee Products, Inc.
Printed in the USA