

# OWNERS MANUAL

MODEL:

# SNOW BLITZ

Portable Snow Cone Machine

PART NUMBER:

# 71050

120 volts, 60 hz



**WARNING ELECTRICAL SHOCK HAZARD.**

**FAILURE TO FOLLOW THESE INSTRUCTIONS COULD RESULT IN SERIOUS INJURY OR DEATH.**

WARNING: Handling the cord on this product may expose you to lead, a chemical known to the State Of California to cause cancer and birth defects or other reproductive harm. WASH HANDS AFTER HANDLING.

1. Electrical ground is required on this appliance.
2. Do not modify the power supply cord plug. If it does not fit the outlet, have a proper outlet installed by a qualified electrician.
3. Do not use an extension cord with this appliance.
4. Check with a qualified electrician if you are in doubt as to whether the appliance is properly grounded.

## SAFETY INSTRUCTIONS

1. Plug electrical cord into a certified electrical outlet with a corresponding voltage rating as listed on the machine model labels.
2. Always unplug the electric cord when appliance is not in use and before cleaning, adjusting or maintaining this steamer. Do not operate with a damaged cord or plug or after the machine malfunctions, has been dropped or damaged. Use authorized service for examination, electrical or mechanical adjustment or repair.
3. This equipment will be HOT during use and for a short time after it is turned off BE CAREFUL. To avoid burns, do not let bare skin touch hot surfaces. If provided, use handles when moving this appliance. Keep combustible materials away from appliance.
4. Extreme caution is necessary when any appliance is used by or near children and whenever the appliance is left operating and unattended.
5. This appliance is not intended for use in wet locations. Never locate appliance where it may fall into a water container.

Do not insert or allow foreign objects to enter any ventilation or exhaust opening as this may cause an electrical shock, fire or damage to the appliance.



# OPERATING INSTRUCTIONS

1. Install the **Pusher** by placing the hinge in the housing on top of the horn and inserting the bolt and tightening the nut. (*Item 7006 see diagram on page 4*)
2. Install the **Ice Tote** by sliding into cabinet under ice chute. (*Item 74001 see diagram on page 4*)
3. Plug the machine into a properly grounded 120 volt power supply. Do not use an un-grounded adapter or extension cord. It is important that the machine remains grounded during operation.
4. Open the Pusher Assembly and fill the Horn with the desired amount of either cube or chunk ice (chunks cannot exceed 3” in diameter). Do not overfill the Horn Assembly. Close the Pusher Assembly once you have the desired amount of ice in the Horn. (*Item 7005 see diagram on page 4*)
5. Press and hold the rocker switch to activate the cutting head while applying downward pressure to the Pusher. (*Item 7015 see diagram on page 4*)
6. Once the desired amount of ice is crushed, release the switch to turn of the motor and cutting head. The power switch is spring loaded so that it cannot be left in the ON position for safety purposes.
7. Scoop the crushed ice into a serving container. *We recommend you use Benchmark USA Six-ounce Snow Cone Cups (Part# 72501) and Snow Cone Dipper (Part# 72305)*
8. Pour or pump snow cone syrup onto the finished cone. (a maximum of two ounces of syrup is recommended for a 6 oz. serving of ice). *We recommend you use Benchmark USA pump (Part# 72301) along with Benchmark USA snow cone syrups (Part#'s 72001 – 72012).*
9. Repeat steps 4-8 for multiple batches.

## CLEANING THE MACHINE

1. Remove all of the residual ice from the horn and collection tray. Operate the motor for a minimum of 30 seconds to remove any water that may have accumulated on the cutting head.
2. Unplug the machine from the power source and with a clean cloth wipe down the ice horn (caution: the cutting blades are sharp), the pusher, outside of the horn assembly, and the ice tote.
3. The ice tote is removable for sink or dishwasher cleaning.
4. Only use cleaning products that are approved for food-zone applications on any of the surfaces of the machine that can touch the food product.

# Adjusting or Replacing Cutting Blades

1. Locate the two set screws in the collar of the cutting head (see figure 1) by reaching in through the horn (see figure 2) and rotating the head until the set screws are on the bottom. (**Caution:** be careful of the sharp blades). You will need to look up through the chute in the



*Figure 1*



*Figure 2 – View through Horn*



*Figure 3 – View through Chute from inside of machine looking up*

2. Loosen the two screws by reaching up through the chute from inside of the machine (**Note:** some models require a 3mm hex wrench and others require a screwdriver).
3. You will now be able to slide the cutting head out through the horn opening.
4. Adjust the blades by loosening the two screws on each blade and sliding the blade up or down to the desired depth and re-tightening the screws. The more blade that is exposed beyond the head will create a coarser ice chip. (see Figures 4 & 5)



*Figure 4 – Fine Setting*



*Figure 5 – Coarse Setting*



*Figure 6 – Motor shaft*

5. Re-install the cutting head onto the motor shaft by sliding it in through the horn opening on the top of the machine.
6. It is **IMPORTANT** that these screws tighten on the flat part of the shaft to insure that they will not come loose. (see figure 6). Make certain that the head is on the shaft as far as it will go and tighten the two screws.

# ASSEMBLY

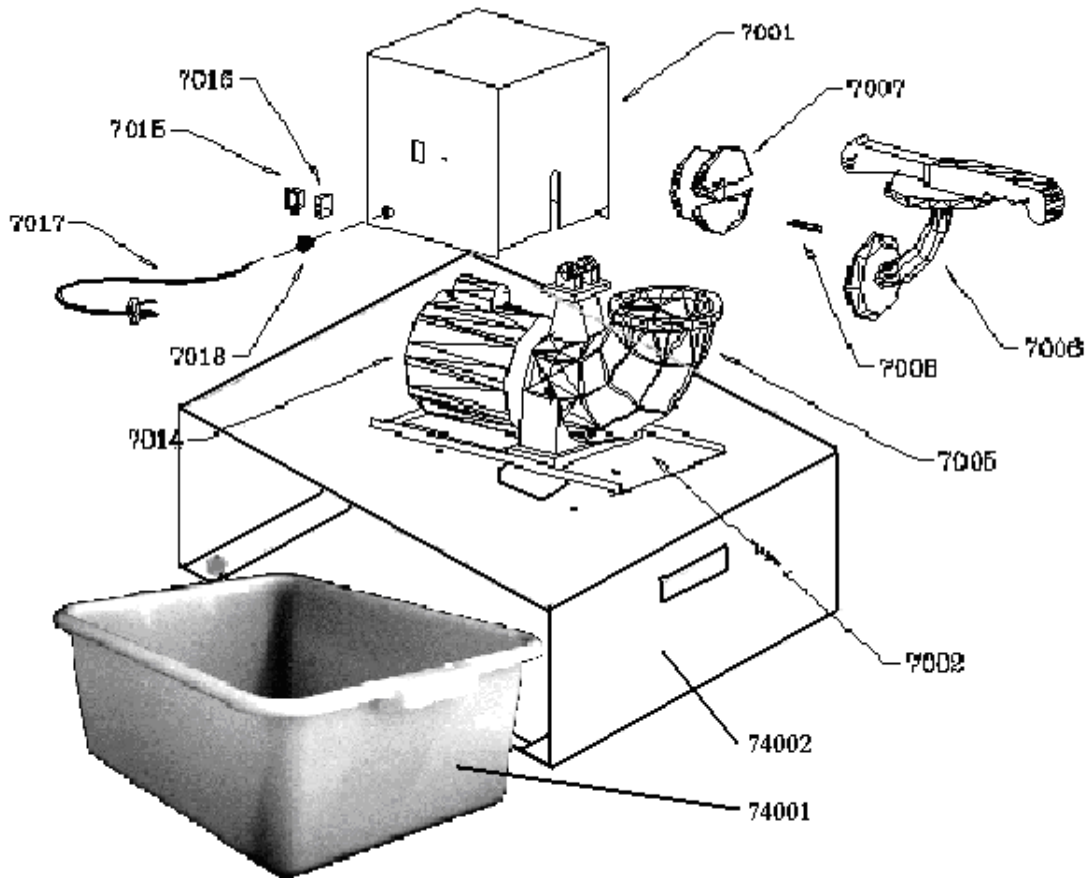

# PARTS LIST

P/N	Description
7001	Motor Housing Cover
7002	Motor Support
7005	Horn Assembly
7006	Pusher Casting
7007	Cutting Head
7008	Cutting Blades (2)
7014	Motor - Snow Bank
7015	Power Switch
7016	Re-set Button
7017	Power Cord
7018	Grommet
7019	Rubber foot
74001	Ice Tote
74002	Cabinet

## **To Order Parts Contact:**

**Benchmark USA, Inc.**

25-J Brookfield Oaks Dr.

Greenville, SC 29607 USA

Tel: 877-432-5500

Fax: 864-312-5505

Email: [parts@benchmarkusainc.com](mailto:parts@benchmarkusainc.com)

# WIRING DIAGRAM

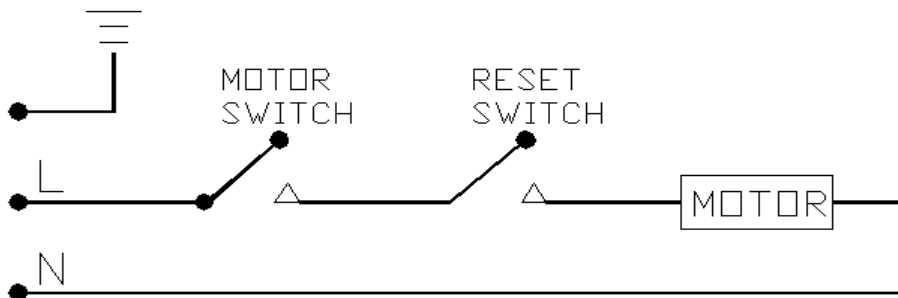
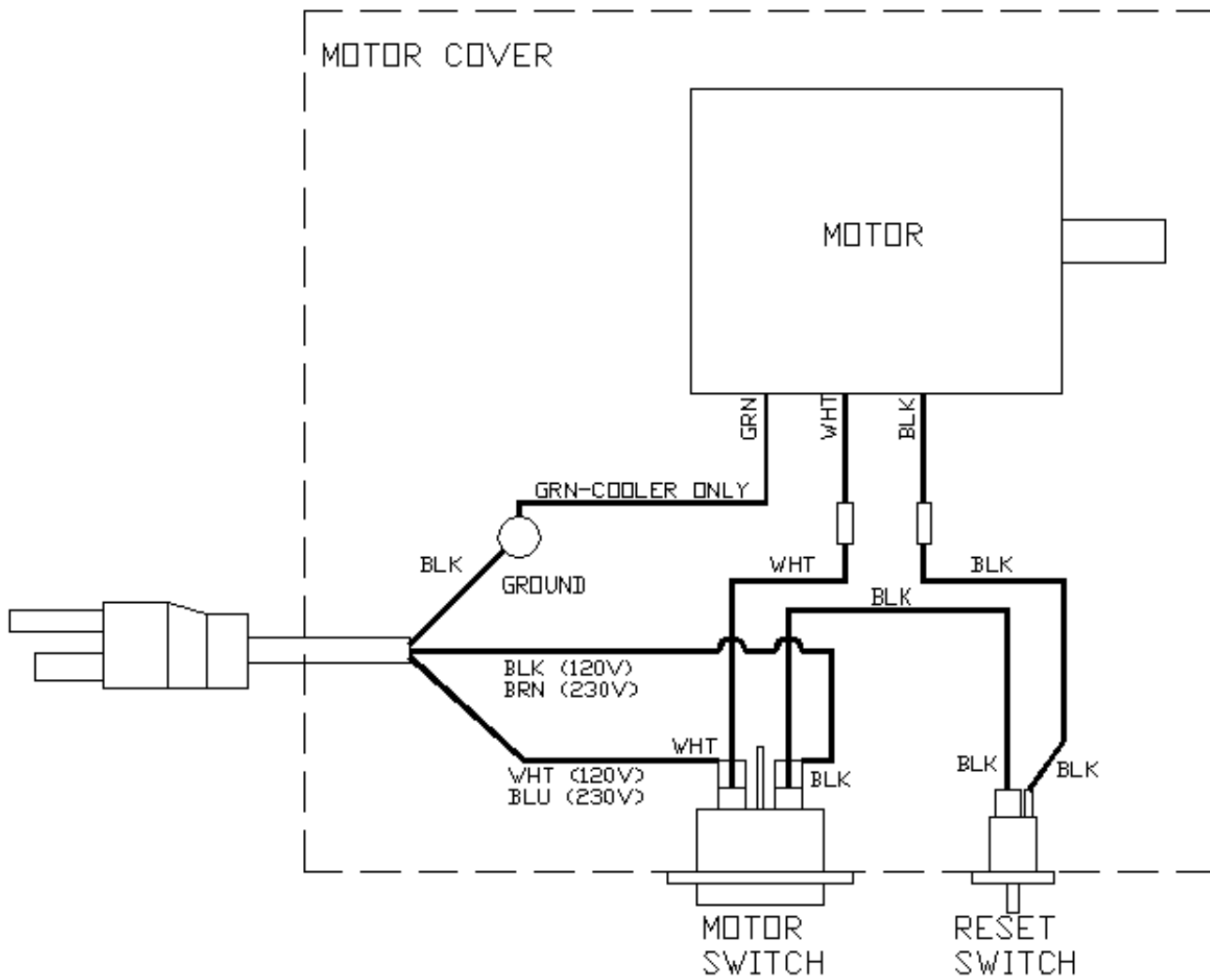

ELECTRICAL SCHEMATIC

# MANUAL RE-SET BUTTON

Your new Benchmark USA “Snow Blitz” ice shaver and snow cone machine is equipped with a manual Re-Set button to prevent injury. In the event the motor should jam, you must re-set the button before restarting the motor. When the motor jams, the machine will stop and you will not be able to activate the motor with the power switch. To re-activate the machine:

1. Release the power switch.
2. Push and release the Re-Set button
3. Push and hold the power switch to restart the motor.

### *If the motor does not re-start:*

1. Unplug the machine from the power source.
2. Remove anything that is jammed in the horn  
(Caution: The blades are sharp)
3. Plug the machine back into the power source.
4. Push and release the Re-Set button.
5. Push and hold the power switch.

# ELECTRICAL REQUIREMENTS

This product requires a properly grounded 120 volt power supply with a minimum of a 15 amp circuit. The “Snow-Blitz” snow cone machine draws 5.3 amps at maximum capacity and depending on what other electrical items you have on the same circuit, you may exceed the circuit capacity.

# SPECIFICATIONS

<b>Voltage</b> .....	<b>120 volts 60 Hz</b>
<b>Amps</b> .....	<b>5.3 amps</b>
<b>Horsepower</b> .....	<b>1/3 hp</b>
<b>RPM</b> .....	<b>1725 rpm</b>
<b>Capacity</b> .....	<b>500 lbs/hour</b>



## ***Three Year Warranty***

### **THE WARRANTY:**

Benchmark USA warrants the original purchaser of new food equipment manufactured by Benchmark USA to be free from defects in material or workmanship from the date of the original purchase for a period of three years.

### **WHO IS COVERED BY THIS WARRANTY:**

The original purchaser who has provided proper proof of the original retail purchase and all other requested information.

### **WHAT IS WARRANTIED:**

The obligation of Benchmark USA under this warranty is limited to the replacement of any parts or components that in the opinion of Benchmark USA are defective, F.O.B. the factory, or at any other location that Benchmark USA may designate.

### **WHAT VOIDS THE WARRANTY:**

1. Any piece of equipment that has been installed, operated or maintained inconsistently with Benchmark USA operating instructions.
2. Any part or component that has been modified, changed or altered from its original configuration.
3. Any electrical component that has been damaged due to submergence in any liquid.
4. Any part or component that has been subject to abuse, misuse, neglect or accidents.

### **EXTENT OF WARRANTY:**

Any defective component, part or assembly returned to Benchmark USA will be replaced by Benchmark USA. Benchmark USA will not be responsible for any expenses incurred by the customer under the terms of this warranty, nor shall it be responsible for any damages either consequential, special, contingent, or otherwise; or expenses or injury arising directly or indirectly from the use of a Benchmark USA product. Any component, part or assembly returned to Benchmark USA must be returned at the customers expense along with proof of purchase. Benchmark USA reserves the right to determine whether the terms of this warranty have been properly complied with. In the event that the terms are not complied with, Benchmark USA shall be under no obligation to honor this warranty.