



Ice Machine Cleaning & Sanitizing

HOSHIZAKI

KML-250MAH, MWH
KML-351MAH, MWH
KML-451MAH, MWH
KML-631MAH, MWH, MRH

The icemaker must be cleaned & sanitized at least once a year.

Cleaning Prep:

- 1 Remove the **Front Panel**, move the **control switch** to **OFF**. After **3 min.**, move the **control switch** to **ICE**, then replace the **Front Panel**.
 - 2 After **3 min.**, remove the **Front Panel**, move the **control switch** to **OFF**. This removes the cubes from the evaporator.
 - 3 Remove all ice from the dispenser unit/ice storage bin.
- ! ATTENTION! IF ON DISPENSER**, turn off the dispenser power supply after dispensing all the ice.

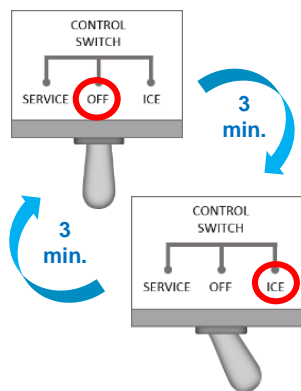

! ATTENTION!

Do not leave icemaker unattended when panels are off

**AMMONIA
Cleaners**



Sanitizing:

- Dilute 5.25% chlorine bleach* with warm water (see Table below)

KML-451 and smaller	
Bleach	1 fl. oz (30 ml)
Warm Water	2 gal. (7.6 l)
KML-631	
Bleach	1.25 fl. oz (37 ml)
Warm Water	2.5 gal. (9.5 l)

* Use bleach without additives.

Cleaning:

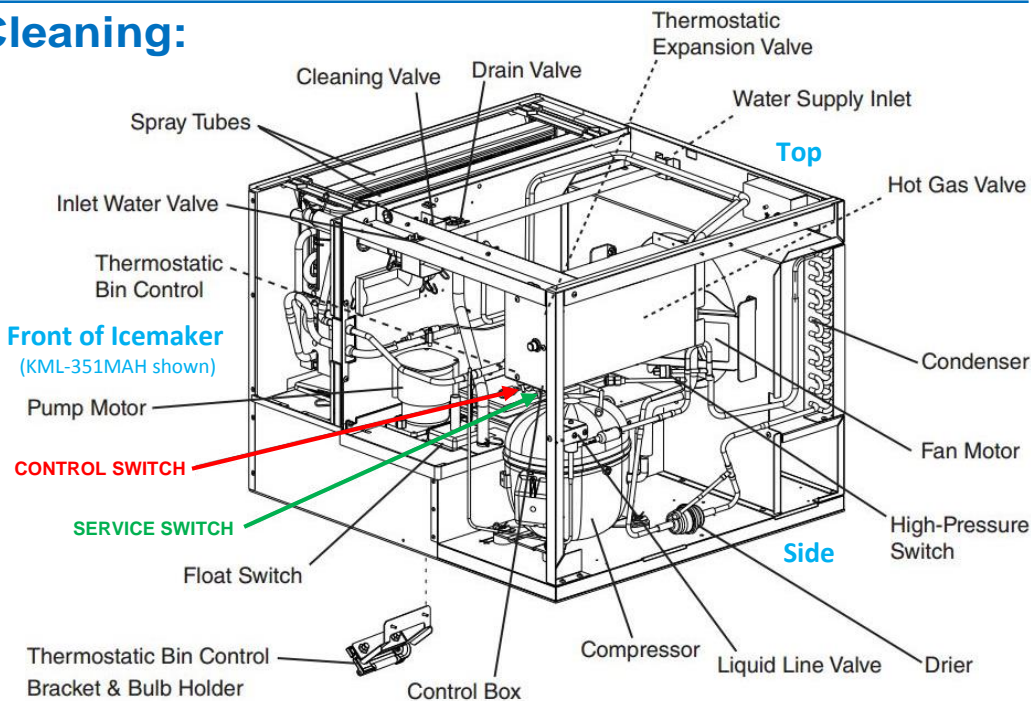

- 4 Remove the **Front Panel**, move the **service switch** to **DRAIN**. Move **control switch** to **SERVICE**. Replace the **Front Panel**.
- 5 After **2 minutes**, remove the **Front Panel**, move the **control switch** to **OFF**.
- 6 Dilute Hoshizaki **Scale Away** with warm water (see Table below). Remove the **Front Insulation Panel** and pour cleaning solution into the water tank. Replace the **Front Insulation Panel**.

Model	Scale Away	Warm Water
KML-451 and Smaller	10.5 fl. oz. (310 ml)	2 gal. (7.6 l)
KML-631	13.5 fl. oz. (400 ml)	2.5 gal. (9.5 l)

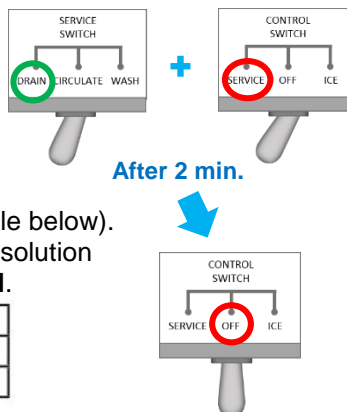

- Remove the front insulation panel
 - Pour the sanitizing solution into the water tank
 - Replace the front insulation panel
- 16 Move **service switch** to **WASH** and **control switch** to **SERVICE**, replace the front panel
 - 17 After 15 minutes, remove front panel
 - Move **service switch** to **DRAIN**, replace the front panel
 - After 2 minutes, remove front panel
 - Move **control switch** to **OFF**

↪ continued on the back...

- 7 Move the **service switch** to **WASH**, and the **control switch** to **SERVICE**. Replace **Front Panel**.
- 8 After **30 minutes**, remove **Front Panel**, move the **service switch** to **DRAIN**. Replace **Front Panel**.
- ATTENTION!** To prevent damage to the water pump, do not leave the control switch on SERVICE for extended periods when water tank is empty.
- 9 In bad water conditions, a more thorough cleaning may be required. Move **control switch** to **OFF**, then turn off the power supply. Dilute **5 oz. of Scale Away to 1 gallon of warm water**. Remove and clean the cube guides, float switch assembly (remove & clean all float parts), water supply tubes, spray tubes, and spray guides. Rinse thoroughly, then replace in their correct positions. Turn the power supply back on. Otherwise, continue to Step 10.

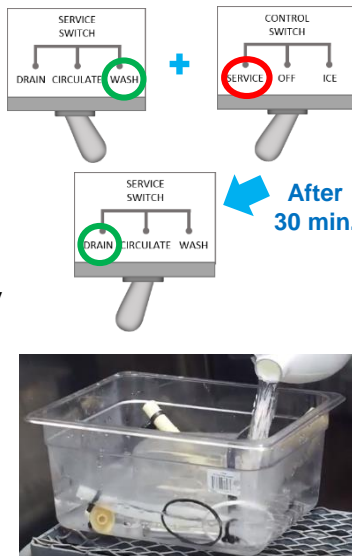

Cleaning Rinse:

- 10 After **2 minutes**, remove **Front Panel**, move the **control switch** to **ICE**. Replace **Front Panel**.
- 11 After **3 minutes**, move the **service switch** to **WASH**, and the **control switch** to **SERVICE**. Replace **Front Panel**.
- 12 After **5 minutes**, remove **Front Panel**, move the **service switch** to **DRAIN**. Replace **Front Panel**
- 13 After **2 minutes**, remove **Front Panel**, move the **control switch** to **OFF**.
- 14 Repeat 3x (**Steps 10 thru 13**) to rinse thoroughly. Continue to **Sanitation – Step 15** on front...

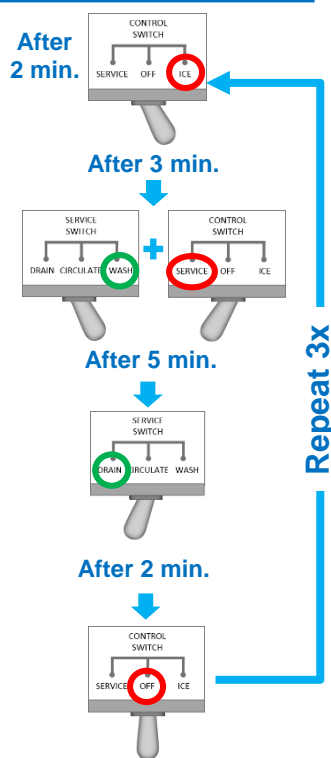

sanitizing continued...

- RINSE 1:** (Steps 18-21)
- 18 Move **control switch** to **ICE**, replace front panel
 - 19 After 3 minutes, remove the front panel
 - 20 Move **service switch** to **WASH** and **control switch** to **SERVICE**, replace the front panel
 - 20 After 5 minutes, remove the front panel
 - 20 Move **service switch** to **DRAIN**, replace the front panel
 - 21 After 2 minutes, remove the front panel
 - 21 Move **control switch** to **OFF**, replace the front panel
- RINSE 2:**
- 22 Repeat RINSE 1 (Steps 18–21) for complete ice/food safety
 - 23 Clean the dispenser unit / ice storage bin liner with a neutral cleaner (dish soap)
 - 23 Rinse thoroughly
 - 24 Move **control switch** to **ICE**, replace front panel

AMMONIA Cleaners



DOWNLOAD COMPLETE INSTRUCTION MANUAL:



hoshizakiamerica.com/manuals

Type in the model number of your icemaker (including dashes) to download manuals

CLEANING SCHEDULE

- | | |
|----------------------|----------------------------|
| ● Scoop | Dish soap, rinse well |
| ● Water Filters | Check psi, change if req'd |
| ● Exterior | Dish soap & damp cloth |
| ● Bin Door/Top Kit | Warm water & clean cloth |
| ● Icemaker/Bin | Follow these instructions |
| ● Water Supply Inlet | Clean inlet screen |
| ● Condenser | Inspect. Clean with brush |
| ● Water Hoses | Inspect. Replace if req'd |
- DAILY | ● MONTHLY | ● YEARLY

ATTENTION!

DO NOT use ammonia type cleaners. Can cause damage to icemaker

WEAR liquid-proof gloves and goggles to protect skin & eyes from cleaning & sanitizing chemicals

ATTENTION!

IF ICEMAKER IS ON DISPENSER, remember to turn on the dispenser after cleaning