

WALK-IN SPECIFICATIONS

SIZE: 7'-9" X 5'-10" X 7'-6 1/4"

PANELS: ALL FOAMED PANELS ARE 4"

EXTERIOR FINISH: ALL 26GA STUCCO GALVALUME

INTERIOR FINISH: ALL 26GA STUCCO GALVALUME

FLOOR TYPE: COOLER - .100 SMOOTH ALUMINUM

HEIGHT: DD 7'-6 1/4" ID 6'-10 5/8"

DOORS: 46x82.25DS 26x78 DR STD CLR 115-60-1/1.0 AMPS

ACCESSORIES: (NONE)

REFRIG. PC049T2 1/2HP 115/60/1 9.9 AMPS

USE this drawing for installation

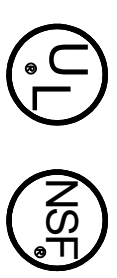

IMPORTANT NOTES:

- 1) ALLOW MINIMUM 1' CLEARANCE ALL AROUND WALK-IN.
- 2) WALK-IN CEILING IS NOT DESIGNED FOR FOOT TRAFFIC OR STORAGE.
- 3) GENERAL CONTRACTOR TO REFER TO DESIGN AND SPECIFICATIONS MANUAL FOR FLOOR DETAIL INFORMATION.
- 4) SPECIAL NOTE TO GENERAL CONTRACTOR AND SUBCONTRACTOR FOR QUARRY TILE OR CONCRETE WEARING FLOOR - THE SHEET METAL PANEL FACINGS MAY BE SUSCEPTABLE TO STAINING DUE TO EXCESSIVE MOISTURE CREATED BY THE HYDRATION OF CONCRETE TYPE MATERIALS. THEREFORE, IT IS ABSOLUTELY NECESSARY THAT EACH ROOM BE PROPERLY VENTILATED. ALSO NOTE THAT SPECIAL PRECAUTIONS MUST BE TAKEN WHEN USING MURIC ACID DUE TO EFFECTS HYDROCHLORIC ACID FUMES HAVE ON ALUMINUM AND STAINLESS STEEL MATERIALS.

COOLER

OPTION A DOOR SWING

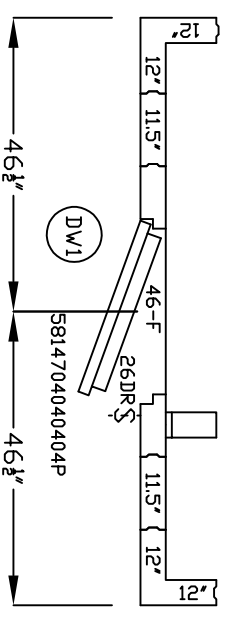

OPTION B DOOR SWING

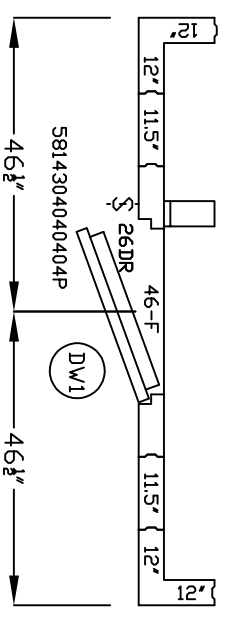

ORDER# _____

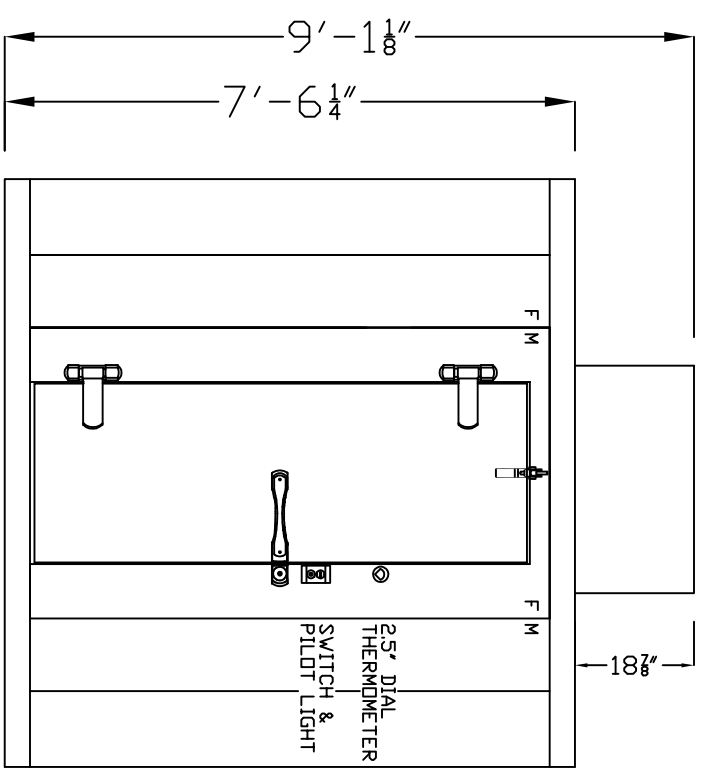

DOOR ELEVATION
46x82.25DS 26x78 DR P-P-CLR
THRESHOLD DETAIL 01

LH SHOWN
RH OPPOSITE



2915 TENNESSEE AVENUE NORTH
P.O. BOX 550
PARSONS, TN. 38363
(901) 847-6361

DEALER:

PROJECT: 7'-9" X 5'-10" X 7'-6 1/4"

DRAWN BY:

DATE:
06/15/15

SCALE:
3/8"=1'-0"

DRAWING NO.
QS7-086-CT