



ProGuard® Wet/Dry & ProBlitz® AirMover

QUICKLY REMOVE & PREVENT WATER DAMAGE

The pipe bursts, food fight, stepped-in-mud, flash flood, post-party, inclement weather, floor stripping, quick-recovery solution for any facility.





WET/DRY VACUUM SOLUTION

Have the right equipment on hand to respond to any challenge big or small – quickly and conveniently. ProGuard Wet/Dry Vacuums deliver unmatched power, performance and durability and include thoughtful features that make our vacuums easier and more convenient to use.

ProGuard Wet/Dry Vacuums are 6 models that vary in size and functionality – each designed to take on different maintenance situations.

LOSE THE TRACKS – Tracking in Wet Weather

70% to 80% of dust, grime and dirt gets tracked in from the outside on people’s feet - permanently damaging floors.

Equipping a Facility for the Expected

Save Time – Save Money – Save Energy when stripping your floors.

ProGuard Front Mount Squeegee System:

- Quick removal of slurry ensures stripper doesn’t dry on floor
- Large squeegee reduces number of passes
- Increases productivity, ideal for fast stripper recovery



See it in action at:

www.pro-team.com/ProGuardFloorStripping

FACT:

85% of Workers Compensation claims are attributed to employees slipping on slick floors.



Source: National Floor Safety Institute, Industrial Safety & Occupational Health Markets 5th Edition.

Equipping a Facility for the Unexpected

In the event of a flood, there is little time to dry out areas before warping, discoloration or structural damage can occur. A seemingly small amount of moisture can end up causing damage that diminishes the visual appeal and reduces the resale value of the building. When a quick response time can mean the difference between minor cleanup and major restoration, it pays to have a wet/dry vacuum and an air mover on the premises.

APPLICATIONS



Entryway / Walk Off Mat



Extreme Weather Condition



Transportation



Emergency Spill



Floor Stripping



Jobsite Maintenance

PRODUCT LINE UP

ProTeam
Cleaning for Health® Since 1987

THE RIGHT TOOL FOR THE RIGHT JOB



PREVENT PERMANENT DAMAGE TO FLOORING

With 3 fan speeds and 3 operating positions, the ProBlitz AirMover dries carpets and sub-floors quickly with the ultimate quiet performance.



- **Easy Transport** – Optional telescoping handle and wheels (ProBlitz XP only)
- **Flexibility** – Three operating positions to direct air where you need it
- **Stackable** – Convenient storage
- **Low Amp Draw** – Multiple units on a single circuit
- **Quiet** – Operate without disruption
- **Reduce Re-soiling** – High-speed drying after wet extraction

ADVANTAGES

- **EASE OF USE** – Fast and easy liquid debris removal from either the tip and pour spout or the convenient drain hose
- **CONVENIENCE** – commercial grade tools remove dirt, water and sludge
- **PRODUCTIVITY** – Front mount squeegee provides fast floor stripper recovery and flood restoration applications
- **SAVE TIME** – Qwik-Lock® wet filter maximizes tank capacity and provides easy filter changes
- **DURABILITY** – Exclusive Qwik-Lock Wet Filter and mechanical float shut-off breaks down foam and protects vacuum motor from debris and moisture damage
- **LOW COST OF OWNERSHIP** – Ease of cleaning, filter maintenance
- **IMPROVED FILTRATION** – 3-layer fine dust cartridge filter is washable, reusable and clogs less than the standard foam filters
- **MANEUVERABILITY** – Built-in variable swivel caster wheel pattern allows for either 360-degree or stair-ready maneuverability

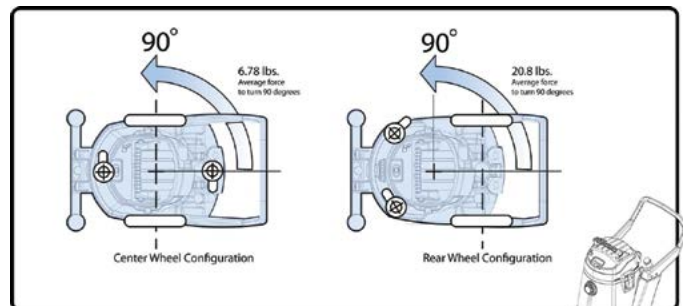

It takes **1/3** the effort to turn this vacuum when using the center wheel configuration!

PROOF POSITIVE

"The reason I selected the ProGuard from what is available on the mass market today is how user-friendly and compact they are," said Aron Griffith, Director of Club Services at GoodLife Fitness the Canadian owned and operated health club chain. Fifty locations now use the 12-pound ProGuard@ 4 Portable Wet/Dry vacuum to manage soil and moisture in their high-traffic entryways. "There's nothing tricky about them," said Griffith. "You just turn on and go."

"I've gotten very positive feedback on the ProGuard from our guys," said Randy Abernathy, President and Owner of Van-guard Cleaning Systems, a franchise commercial cleaning company that provides services for over 10,000 companies in North America. The vast majority of the wet/drys are being used after hard floor stripping to pick up the sludge before waxing.

"The ProGuard is quieter and less expensive but more flexible," said Abernathy, comparing them to the older wet/drys. "They are less physically straining to dump."

Ruben Rives, the owner and founder of H2Only Renewable Cleaning, uses pressurized water in restrooms to agitate surface soil in school restrooms. Rives has assembled his own spray-and-extract system using a spray nozzle attached to the bathroom top and a 10-gallon Proteam ProGuard@ wet/dry vacuum with a modified squeegee.

"First I got a special fitting for the hose that mimics the spray of a fireman's hose. I spray, and then I pick it up with the Proteam wet/dry vacuum," said Rives. "Urine is a big problem in the boy's bathroom. Spraying and extracting eliminates all of the urine smell."

The ProGuard 10 Wet/Dry has a two-stage bypass motor that creates 105 CFM and 95-inches of water lift, plenty for capturing the soiled water after pressure washing. Then his employees wipe down all touch points with microfiber. Even with their meticulous approach, this method reduced the cleaning time for a 190 square foot restroom from 30 minutes to 22 minutes – a 25% reduction.

"I like the mobility of the ProGuard," said Rives. "It rolls perfectly, and it has a long hose. The wand is light."

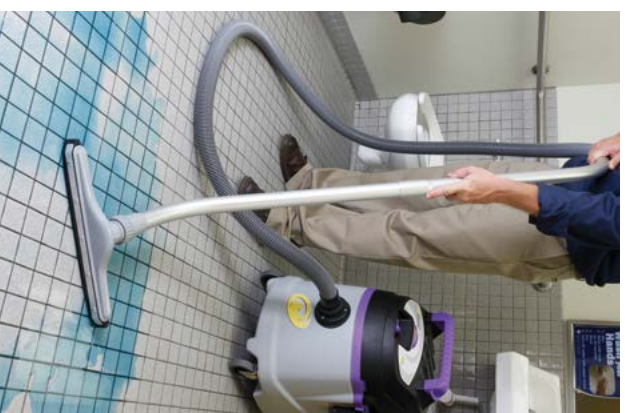

	ProBlitz	ProGuard LI 3 Cordless	ProGuard 4 Portable	ProGuard 10	ProGuard 16 MD	ProGuard 15/20
Part Number	107132 (ProBlitz) 107133 (ProBlitz XP)	107127	107128	107129	107386	107359 (PG 15 w/Fnt Mnt Squeegee) 107360 (PG 20 w/Fnt Mnt Squeegee) 107130 (PG 15) 107131 (PG 20)
Motor	.4 HP/360 W/Capacitor Start, 2.4 - 3 A	18 Volt, permanent magnet DC	1080 W, 9 A	1380 W, 9.5 A	1380 W, 9.5 A	1380 W, 9.5 A
Airflow	2200 CFM (max)	60 CFM	142 CFM	105 CFM	105 CFM	105 CFM
Static Lift	N/A	38"	51"	95"	95"	95"
Tank Size	N/A	3 gallon/11.4 L	4 gallon/15.2 L	10 gallon/38 L	16 gallon/60.6 L	15 gallon/57 L 20 gallon/76 L
Weight	28 lbs./12.7 kg	10.5 lbs./4.8 kg	12 lbs./5.5 kg	28 lbs./12.7 kg	29 lbs./13.2 kg	PG 15 - 68 lbs./31 kg PG 20 - 70 lbs./32 kg
Decibel	Low - 63 dBA Medium - 65 dBA High - 66 dBA	72 dBA	76 dBA	68 dBA	66 dBA	69 dBA
Power Supply	30' Power Cord, 18-3 AWG w/ Grounding Plug	Lithium Ion Battery Approx. Run Time: 11 min. Approx. Charge Time: 30 min.	20' Power Cord, 18 AWG	50' Power Cord, 14 AWG	50' Power Cord, 16 AWG	50' Power Cord, 14 AWG
Warranty	3 years - parts, labor & motor Lifetime - molded body parts	3 years - parts & labor 1 year - motor, battery & charger Lifetime - molded body parts	3 years - parts & labor 1 year - motor Lifetime - molded body parts	3 years - parts, labor & motor Lifetime - molded body parts	3 years - parts, labor & motor Lifetime - molded body parts	3 years - parts, labor & motor Lifetime - molded body parts

PERFORMANCE SPECS BASED ON MOTOR SPECS



www.pro-team.com

866.888.2168 | customer.service.proteam@emerson.com

