

# Advisory Bulletin



BUILDING VALUE SINCE 1906

## TB-99 Cleaning and Maintenance For Bobrick B-824 or B-828 Automatic Counter-Mounted Soap Dispensers

Quality soap dispensers require good quality soap and periodic maintenance to properly operate. For reliable long-term use, perform regular maintenance for each unit. Most soap dispenser problems are caused by soap that is too thick or corrosive, or by a lack of maintenance. If proper soap is being used, problems can still arise if dispensers have never been cleaned. Bobrick recommends a viscosity of 100cps. With proper maintenance and soap, Bobrick dispensers will provide long term, trouble free operation.

Warning: Only use soap designed specifically for foaming on the B-828 foam dispenser. Not doing so will result in unit not operating properly, or can lead to total product failure.

Determine which unit you have:

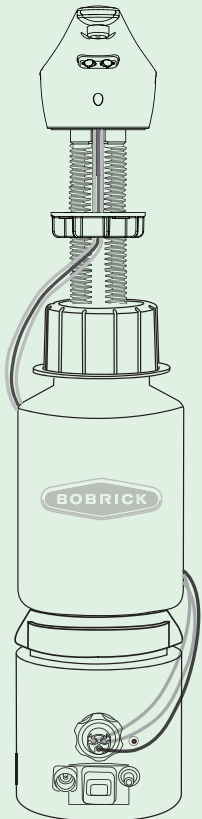

B-824

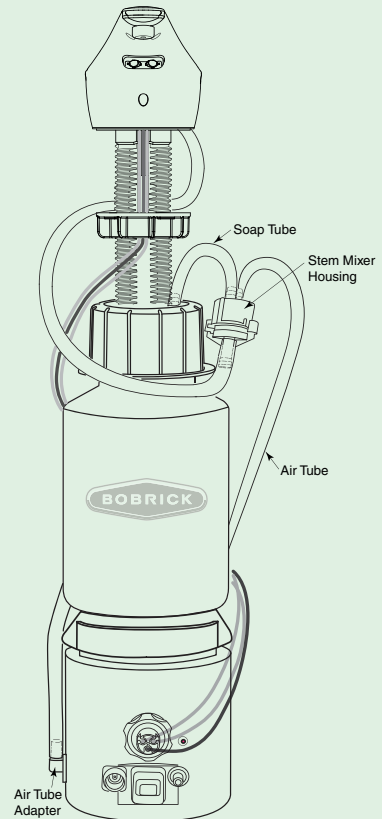

B-828

DO NOT use abrasive or chemical cleaners (including chlorine bleach) to clean Spout, as it may dull the luster and attack the chrome-plated exterior. Use ONLY mild soap and water, then wipe dry with clean cloth. While cleaning the bathroom counter top, protect the Spout from any splattering of cleaner. Acids and cleaning fluids will discolor or remove chrome plating.

Deactivate the soap dispenser by placing your finger over the Fiber Optic Sensor area while you clean. The sensor is located just behind the Nozzle Tip. Once dispenser is cleaned, remove finger from the sensor area. Or un-plug the Power Supply located on the bottom of the housing (LED will not light).

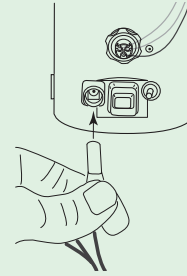
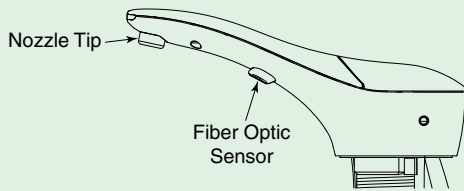

### Daily cleaning:

- Using a soft, dry cloth wipe the exterior.
  - If dispenser is really dirty gently wipe the dispenser with a cloth moistened with warm water and a diluted neutral detergent. Remove the detergent with a soft damp cloth and then rub with a second soft, dry cloth.

### Monthly cleaning

- For Liquid or Foam soap dispenser remove Nozzle Tip and run under warm water.
  - To remove Nozzle Tip for cleaning, cover the Sensor area with your finger to prevent dispensing of soap. Turn Nozzle to the left to loosen. Rinse Nozzle under hot water to loosen any soap residue and replace. Turn Nozzle to the right to tighten
- Place hand under Nozzle Tip to be sure soap is properly dispensed

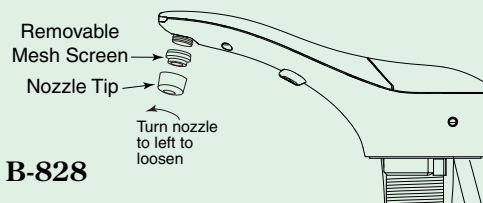
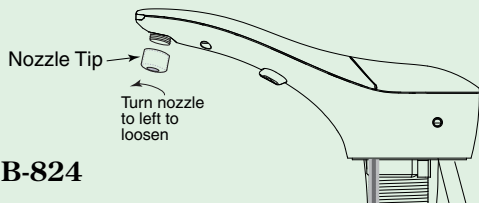

### Periodic cleaning (3 to 6 months)

- Gently wipe the dispenser with a cloth moistened with warm water and a diluted neutral detergent
- Clean area between Lid and Spout to keep Lid swing free of soap residue
- Flush the system when minimal amount of soap is left in the bottle
  - Open the top-fill door using the BobKey, rotate door clockwise
  - Fill the dispenser with warm water.
  - Press the Automatic Flush Button located on the bottom housing assembly, just above the Partition Control Knob.
  - Once unit is flushed, Press the Automatic Flush Button again to stop dispensing.
  - Fill unit with fresh soap.
- Place hand under Nozzle Tip to be sure soap is properly dispensed.

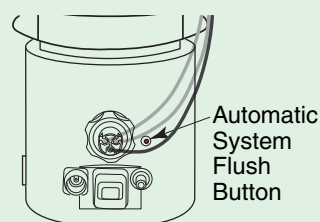
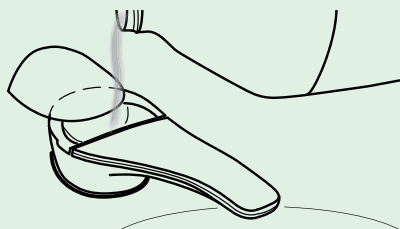



BUILDING VALUE SINCE 1906

# Trouble Shooting Guide

## for Bobrick B-824 SureFlo® Automatic, Top Fill Bulk Liquid Soap Dispenser

**Step 1: To determine cause: Unplug unit and reconnect unit look for Green LED light and sound of motor. Activate soap dispenser continually five times.**

<b>If motor running and LED lights up.</b>			
<i>Likely Cause</i>	<i>Action</i>	<i>Instruction</i>	<i>Replacement Part/Kit Needed</i>
Clogged Nozzle Tip.	Remove Nozzle Tip.	Clean Nozzle by soaking in warm water and replace. Flush whole system. If Nozzle continues to be clogged replace.	824-210
Soap may be too viscous (i.e. Soap may be too thick).	Ensure that soap meets specified viscosity range. Viscosity range of 1cP to 19,000cP (cP = centerpoise). Adjust portion control knob to get desired amount of soap.	Replace with soap that is within the recommended viscosity range.	n/a
If unit requires multiple (more than 5) activations to dispense liquid. Duckbill or O-Ring missing or not installed properly.	1. Disconnect fiber optic cables and power sully from Bottom Housing. 2. Unscrew Bottle Cap and remove Bottle. 3. Check Duckbill Valve and O-Ring are in correct location.	1. Re-Insert Duckbill Valve and O-Ring. Found in Retianer Back #10 on parts list. Refer to step 7 on installation instructions. 2. Screw Bottle Cap back on Bottle. #8 on parts list. 3. Re-connect fiber optic cables from Bottom Housing. #19 on parts list.	824-481 (O-ring) 822-35 (duckbill)
No change.	All steps above completed.	Return entire unit to manufacturer.	B-824
<b>If motor not running and LED lights up.</b>			
<i>Likely Cause</i>	<i>Action</i>	<i>Instruction</i>	<i>Replacement Part/Kit Needed</i>
Issue with Power Source this is determined by Flashing red LED.	Check batteries. Check A/C adapter connection.	Replace with new batteries. Reconnect A/C adapter connection.	n/a
Gear jamming.	Check for dried soap. Purge system.	Open Cover, pour warm water, and then purge by pressing Automatic System Flush Button.	n/a
Flashing green LED. Indicates sensor obstruction.	Ensure all obstructions are clear from sensor path.	Refer to mounting template <b>824-207</b> .	n/a
No change.	All steps above completed.	Return entire unit to manufacturer.	B-824
<b>If motor not running No LED light.</b>			
<i>Likely Cause</i>	<i>Action</i>	<i>Instruction</i>	<i>Replacement Part/Kit Needed</i>
No power to the unit	Replace with new batteries. Check A/C adapter connection.	If LED lights up then follow the steps listed under <b>“If motor not running and LED lights up”</b> .	n/a
No change.	All steps above completed.	Return entire unit to manufacturer.	B-824
<b>Unit Not Dispensing</b>			
<i>Likely Cause</i>	<i>Action</i>	<i>Instruction</i>	<i>Replacement Part/Kit Needed</i>
Loose bottle cap connection to Bottom Housing.	Unscrew bottle cap.	Ensure the gaskets and washer are installed properly (picture below). Re-install and tighten bottle cap.	n/a
Leaking from bottom of Bottom Housing.	1. Disconnect fiber optic cables and power supply from the Bottom Housing. 2. Locate leak if from bottom of Bottom Housing.	Ensure that the bottom of Bottom Housing is properly tightened.	n/a
No change.	All steps above completed.	Unit needs to be returned. If the Yellow Label on the soap bottle says “Dark lens” then replace with Bottom Housing Assembly Liquid Kit (dark lens) <b>824-450</b> . If the soap bottle does not say “Dark Lens” then replace the whole assembly.	824-450 B-824
<b>Unit Leaking</b>			

**B-824 Parts List:**

**Item Description**

- |    |  |         |
|----|--|---------|
| 1  | Top Assembly with Spout, Door, Shank, and fiber optics                                       | 824-425 |
| 2  | LED Light  |         |
| 3  | Liquid Nozzle Tip  | 824-210 |
| 4  | Fiber Optic Insert with Sensor Lenses  | 824-229 |
| 5  | Rubber Counter Gasket  | 824-74  |
| 6  | Wave Washer  | 824-109 |
| 7  | Mounting Nut   | 824-68  |
| 8  | Bottle Cap   | 824-70  |
| 9  | Retainer   | 824-155 |
| 10 | Retainer Back  | 824-101 |
| 11 | Screw  | 824-162 |
| 12 | Rubber QC Gasket   | 824-110 |
| 13 | Stainless Steel Washer   | 824-480 |
| 14 | Rubber QC Gasket   | 824-110 |
| 15 | Adapter  | 824-137 |
| 16 | Bottom Housing Assembly (includes Soap Bottle)   | 824-450 |
| 17 | Battery Pack (Requires (4) "D" cell alkaline batteries not included)                         | 824-241 |
| 18 | (3) Fiber Optic Cables for Sensor and LED Light Pipe   |         |
| 19 | Fiber Optic Connector Tip Assembly   |         |
| 20 | Fiber Optic Nut  |         |
| 21 | Portion Control Knob   |         |
| 22 | Automatic System Flush Button  |         |
| 23 | Key Hole   |         |
| 24 | BobKey   | 24-17   |
| 25 | Fiber Optic Cable Cover  |         |
| 26 | Mounting Template  | 824-207 |
| 27 | Optional: A/C Adapter Kit with U. S. Plug  | 3974-57 |
|    | Optional: A/C Adapter Kit with plugs for UK, Europe and Australia, order additional plug kit | 3974-55 |

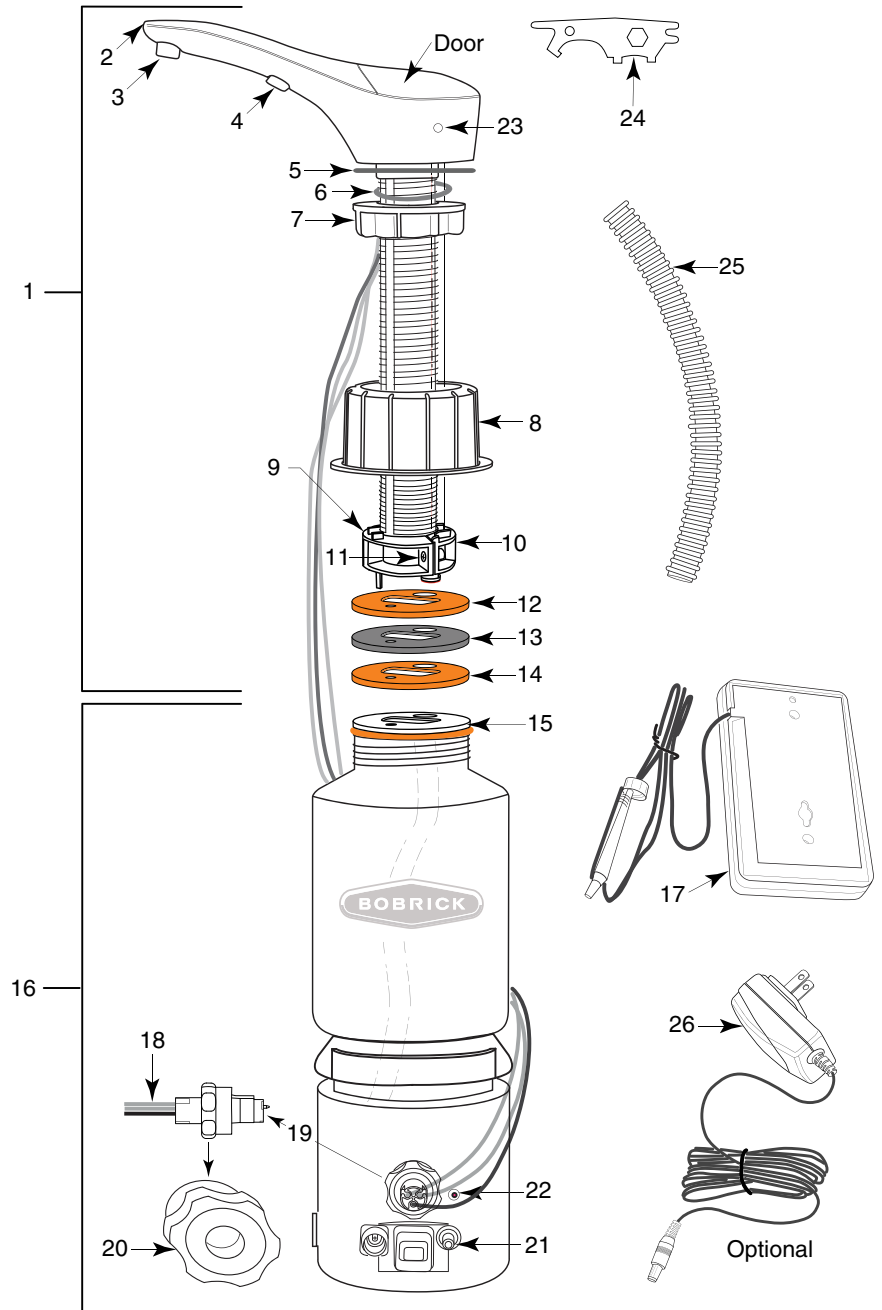

<b>Replacement Parts List</b>	
<b>Description</b>	<b>Part #</b>
Top Housing Assembly Liquid (Dark Lens)	824-425
Bottom Housing Assembly Liquid (Dark Lens)	824-450
A/C Adapter	3974-57
International Assortment Plugs (U. K., Europe, Australia)	3974-58
D Size Battery Pack (Batteries not included)	824-241
Nozzle Tip Replacement Kit Liquid	824-210
Installation Hardware Packet	824-343
O-Ring (Refer to Installation Instructions <b>824-291</b> )	824-481
Duckbill, Rust (Refer to Installation Instructions <b>824-291</b> )	822-35

<b>Recommended Liquid Soaps</b>
MAINTEX EZ Wash
Entral Pink Deluxe Soap
GOJO® Lotion Hand Cleaner
Softsoap® Moisturizing Hand Soap
Dial® Basics HypoAllergenic Liquid Hand Soap
Genlabs Strike Bac® Antibacterial Handsoap
CARROLL ULTREX Antimicrobial Luxury Hand Soap
<i>Recommended soaps are for reference only and do not constitute an endorsement of named manufacturer(s). All registrations and trademarks are the sole property of manufacturer.</i>



BUILDING VALUE SINCE 1906  
BOBRICK.COM

**In the U.S.A.: BOBRICK WASHROOM EQUIPMENT, INC.**

**Los Angeles:** 6901 Tujunga Ave., North Hollywood, CA 91605-6213; Tel: (818) 982-9600, FAX: (818) 503-1102  
**New York:** 200 Commerce Drive, Clifton Park, NY 12065-1350; Tel: (518) 877-7444, FAX: (518) 877-5029,  
or e-mail: customerservice@bobrick.com

**In Canada: BOBRICK WASHROOM EQUIPMENT COMPANY**

45 Rolark Drive, Scarborough, Ontario M1R 3B1  
Eastern Canada Tel: (877) 423-6555, Fax: 877-423-8555; Western Canada Tel: (877) 423-6444, Fax: 877-423-8444,  
or e-mail customerservice@bobrick.com



# Trouble Shooting Guide

## for Bobrick B-828 SureFlo® Automatic, Top Fill Bulk Foam Soap Dispenser

**Step 1: To determine cause: Unplug unit and reconnect unit look for Green LED light and sound of motor. Activate soap dispenser continually five times.**

Unit Not Dispensing	<b>If motor running and LED lights up.</b>			
	Likely Cause	Action	Instruction	Replacement Part/Kit Needed
	Clogged Nozzle Tip and Mesh Screen.	Remove Nozzle Tip.	Clean Nozzle and screen by soaking in warm water and replace. Flush whole system. If Nozzle continues to be clogged replace.	828-210
	Stem Mixer is cracked and leaking.	Replace Stem Mixer.	Return Stem Mixer to manufacturer.	828-215
	Soap may be too viscous (i.e. Soap may be too thick).	Ensure that soap meets specified viscosity range. Viscosity less than 100cps (CPS = centerpoise) Adjust viscosity and Flush system.	Replace soap that is within the recommended viscosity range.	n/a
	Kinked tubing from Top Assembly.	Remove Tubing from the Stem Mixer.	Straighten and re-install around the unit as shown in the below picture. If tubing shows cracks, tears or holes, then replace with Top Assembly. If the yellow label on the soap bottle says "Dark Lens", then replace with only Top Assembly <b>828-425</b> .  If the soap bottle does not say anything about the lens then replace the entire unit.	828-425  B-828
	If unit requires multiple (more than 5) activations to dispense foam. Duckbill inside Stem Mixer missing or not installed properly.	Replace Stem Mixer.	Return Stem Mixer to manufacturer.	828-215
	No change.	All steps above completed.	Return entire unit to manufacturer.	B-828
	<b>If motor not running and LED lights up.</b>			
	Likely Cause	Action	Instruction	Replacement Part/Kit Needed
	Issue with Power Source this is determined by Flashing red LED.	Check batteries. Check A/C adapter connection.	Replace with new batteries. Reconnect A/C adapter connection.	n/a
	Gear jamming.	Check for dried soap. Purge system.	Open Cover and pour warm water and then purge by pressing Automatic System Flush Button.	n/a
	Flashing green LED. Indicates sensor obstruction.	Ensure all obstructions are clear from sensor path.	Refer to mounting template <b>824-207</b> .	824-207
No change.	All steps above completed.	Return entire unit to manufacturer.	B-828	
<b>If motor not running No LED light.</b>				
Likely Cause	Action	Instruction	Replacement Part/Kit Needed	
No power to the unit	Replace with new batteries. Check A/C adapter connection.	If problem persists, return entire unit to manufacturer.	n/a	
No change.	All steps above completed.	Return entire unit to manufacturer.	B-828	
Unit Leaking	Likely Cause	Action	Instruction	Replacement Part/Kit Needed
	Loose bottle cap connection to Bottom Housing.	Unscrew bottle cap.	Ensure the gaskets and washer are installed properly (picture below). Re-install and tighten bottle cap.	n/a
	Leaking from bottom of Bottom Housing.	1. Disconnect fiber optic cables and power supply from the Bottom Housing. 2. Locate leak if from bottom of Bottom Housing.	Ensure that the bottom of Bottom Housing is properly tightened.	n/a
	No change.	All steps above completed.	Unit needs to be returned. If the Yellow Label on the soap bottle says "Dark lens" then replace with Bottom Housing Assembly Liquid Kit (dark lens) <b>824-450</b> . If the soap bottle does not say "Dark Lens" then replace the whole assembly.	824-450  B-824
Soap	Likely Cause	Action	Instruction	Replacement Part/Kit Needed
	Foam Soap CONTAINS TOO MUCH AIR..	Adjust portion control knob. Also check Nozzle Tip Mesh Screen.	Turn knob clockwise for less air in foam. Clean Mesh Screen and/or replace with Nozzle Tip Replacement Kit Foam.	828-210
	Foam Soap contains too much liquid or appears in liquid state.	Adjust portion control knob. Also, check Nozzle Tip Mesh Screen.	Turn knob counter clockwise. If Mesh Screen is torn then replace with Nozzle Tip Replacement Kit Foam. If replacing 828-210 does not fix the problem, then check if the bottom assembly has yellow label that says "Dark Lens": If yes, then replace with Bottom Housing Assembly Liquid Kit (dark lens). If no, then replace the entire unit.	828-210  828-450  B-828

**B-828 Parts List:**

**Item Description**

1	Top Assembly Spout, Door, Shank and Fiber Optics	828-251
2	LED Light	
3	Foam Nozzle Tip with Mixer Cartridge	828-46
4	Fiber Optic Insert with Sensor Lenses	
5	Rubber Counter Gasket	824-74
6	Wave Washer	824-109
7	Mounting Nut	824-68
8	Stem Mixer Housing with Mesh Ring	828-30
9	Bottle Cap	824-70
10	Retainer	824-155
11	Retainer Back	824-101
12	Screw	824-68
13	Rubber QC Gasket	824-110
14	Stainless Steel Washer	824-480
15	Rubber QC Gasket	824-110
16	Adapter	824-137
17	Bottom Housing Assembly (includes Soap Bottle)	
18	Battery Pack (Requires (4) "D" cell alkaline batteries not included)	
19	(3) Fiber Optic Cables for Sensor and LED Light Pipe	
20	Fiber Optic Connector Tip Assembly	
21	Fiber Optic Nut	
22	Portion Control Knob	
23	Automatic System Flush Button	
24	Key Hole	
25	BobKey	24-17
26	Air Tube Adapter	
27	Air Tube	828-32
28	Soap Tube	828-92
29	Fiber Optic Cable Cover	
30	Mounting Template	824-207
31	Optional: A/C Adapter Kit with U. S. Plug	3974-57
	Optional: A/C Adapter Kit with plugs for UK, Europe, Australia	3974-55

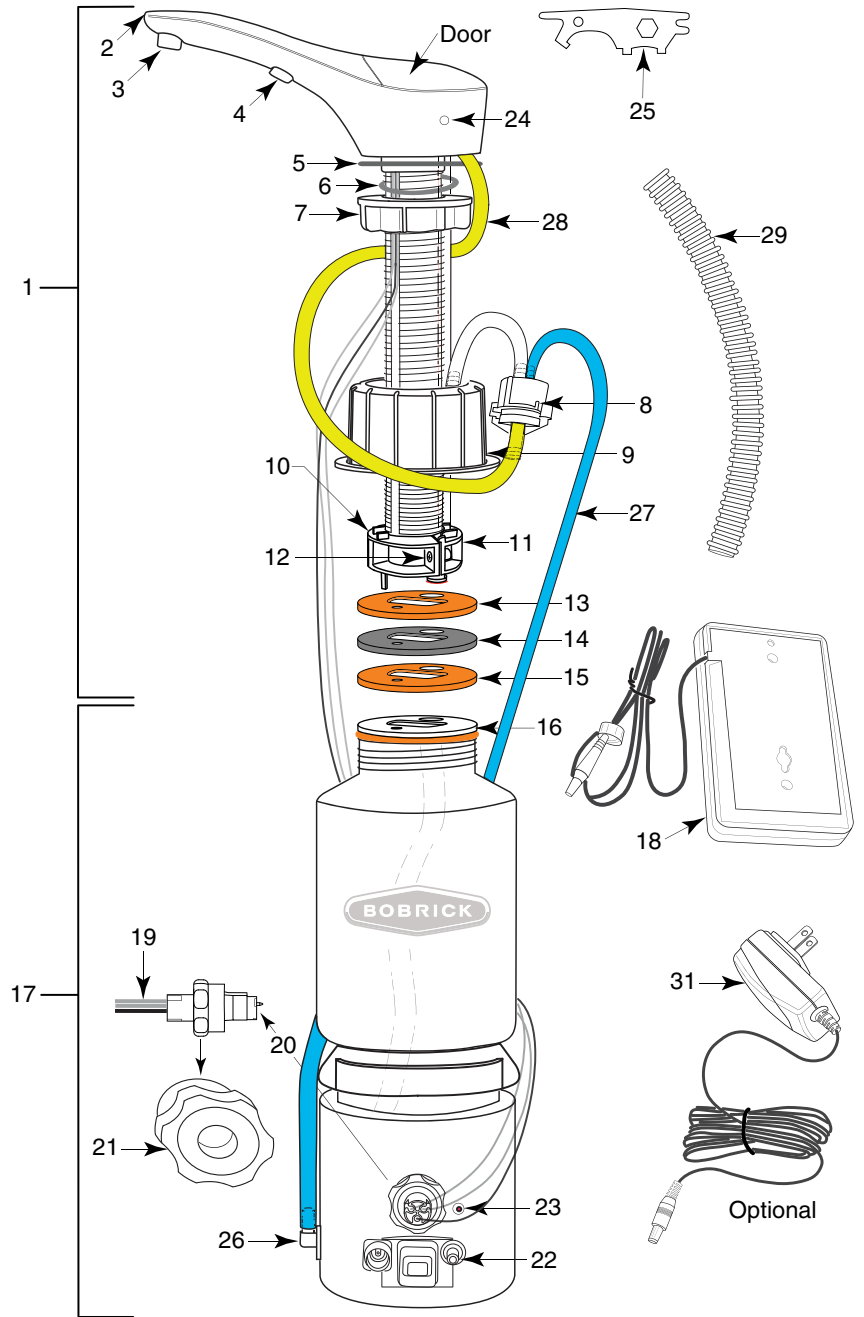

<b>Replacement Parts List</b>	
<b>Description</b>	<b>Part #</b>
Top Housing Assembly Foam (Dark Lens)	828-425
Bottom Housing Assembly Foam (Dark Lens)	828-450
A/C Adapter	3974-57
International Assortment Plugs (U. K., Europe, Australia)	3974-58
D Size Battery Pack (Batteries not included)	824-241
Nozzle Tip Replacement Kit Foam	828-210
Stem Mixer with tubing Kit	848-215
Installation Hardware Kit	828-343

<b>Recommended Liquid Soaps</b>
Kutol Foaming Luxury Hand Soap
Kutol Foaming Antibacterial Hand Soap
Chemcor Foaming Antibacterial Handsoap
State Chemical Gentle Fresh™ Defense Foaming Antibacterial Hand Soap
State Chemical Gentle Fresh™ Foaming Hand Soap
<i>Recommended soaps are for reference only and do not constitute an endorsement of named manufacturer(s). All registrations and trademarks are the sole property of manufacturer.</i>



BUILDING VALUE SINCE 1906

BOBRICK.COM

© 2018 by Bobrick Washroom Equipment, Inc.  
Form No. TSG-B-828 Revised 1/11/18

**In the U.S.A.: BOBRICK WASHROOM EQUIPMENT, INC.**

**Los Angeles:** 6901 Tujunga Ave., North Hollywood, CA 91605-6213; Tel: (818) 982-9600, FAX: (818) 503-1102

**New York:** 200 Commerce Drive, Clifton Park, NY 12065-1350; Tel: (518) 877-7444, FAX: (518) 877-5029,

or e-mail: customerservice@bobrick.com

**In Canada: BOBRICK WASHROOM EQUIPMENT COMPANY**

45 Rolark Drive, Scarborough, Ontario M1R 3B1

Eastern Canada Tel: (877) 423-6555, Fax: 877-423-8555; Western Canada Tel: (877) 423-6444, Fax: 877-423-8444,

or e-mail customerservice@bobrick.com