

38310 STANDARD PUMP KIT DISPENSING & CLEANING INSTRUCTIONS

BENEFITS OF THE 38310 PUMP KIT:

- Dispensing directly from the institutional containers saves time and spill messes by avoiding having to transfer the condiments to other dispensers
- The rugged screw on plastic caps included in this kit fit one gallon jugs, wide and extra wide mouth jars, both plastic and glass and a snap-on cap for the #10 can
- The pump is adjustable to deliver either 1/2 or 1 ounce portions per stroke using the included portion control clip; it easily disassembles for easy cleaning
- Heavy duty plastic construction ensures long
- Snap-Cap for peel-off lid jars is now included in the #38310 Standard Pump Kit; it fits the newer style one gallon condiment jars with "peel-off" lids, 110mm (4-5/16" diameter); simply snaps on and off easily, no threads



THE CARLISLE 38310 STANDARD PUMP KIT INCLUDES:

- One CM1035 plastic pump; delivers 1/2 or 1 oz portions and disassembles for easy cleaning
- Five Caps: 38mm (1-1/2") for one gallon jugs, 110mm (4-5/16") for wide mouth one gallon jars, 110mm snap-cap for peel-off lid and gallon jars, 120mm (4-11/16") for extra wide mouth jars, and 160mm (6-5/16") for #10 cans
- One 7-1/2" plastic dip tube which easily cuts to size to extend pump to reach to the bottom of the containers

OPERATION INSTRUCTIONS:

- Select the proper cap size for your application. Unscrew the CM1035 pump at the screw collar (B) from the body flange (G). Insert the two halves of the pump through the hole in the chosen cap. Reconnect the two halves together via the screw collar (B) to the body flange (G).
- **ADJUSTING THE PORTION AMOUNT:** The pump comes with a portion control clip (C) in place for 1/2 ounce portions. For 1 ounce portions, unscrew pump at the screw collar (B) from the body flange (G) and remove the portion control clip (C).
- The 7-1/2" dip tube (K) can easily be cut to size using scissors for it to reach the bottom of the container

CLEANING INSTRUCTIONS:

- The unit will require daily cleaning
- If the unit is sticking or pumps in a sluggish manner, simply pump warm water through the unit until it clears; if it does not clear or you wish to use the pump in another condiment, a more thorough cleaning described will be needed.
- Unscrew pump at the screw collar (B) from the body flange (G)
- Remove Stainless Steel Spring (I)
- Remove dip tube (K) from the body (H)
- **DO NOT** remove stainless steel ball valve (J)
- Place all the disassembled parts into a pan or sink of soapy, warm water. Soak and scrub lightly and then rinse thoroughly. Reassemble pump and use as normal.

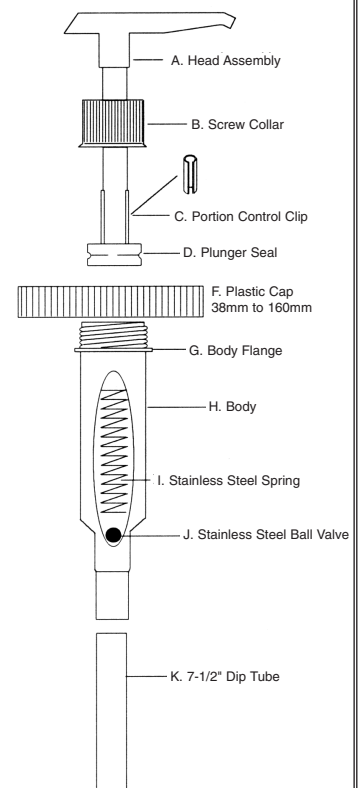

Worldwide Headquarters:
P.O. Box 53006
Oklahoma City, Oklahoma 73152-3006
(405) 475-5600 • FAX (405) 475-5607
1-800-654-8210
website: www.carlislefsp.com
#104T111006

European Distribution Center:
Edisonstraat 84, P.O. Box 110
6900 AC Zevenaar, The Netherlands
Tel +31/(0)316-596550 • Telex 45642
FAX +31/(0)316-340168
4/01

CARLISLE
FoodService Products