

C2510C EZ-FIT® LARGE DELI CUP DISPENSER INSTALLATION INSTRUCTIONS

1. CUT HOLE IN COUNTER SURFACE



2. REMOVE TRIM RING TURNING COUNTER CLOCKWISE

3. SECURE CUP DISPENSER TO COUNTER WITH SUPPLIED SCREWS

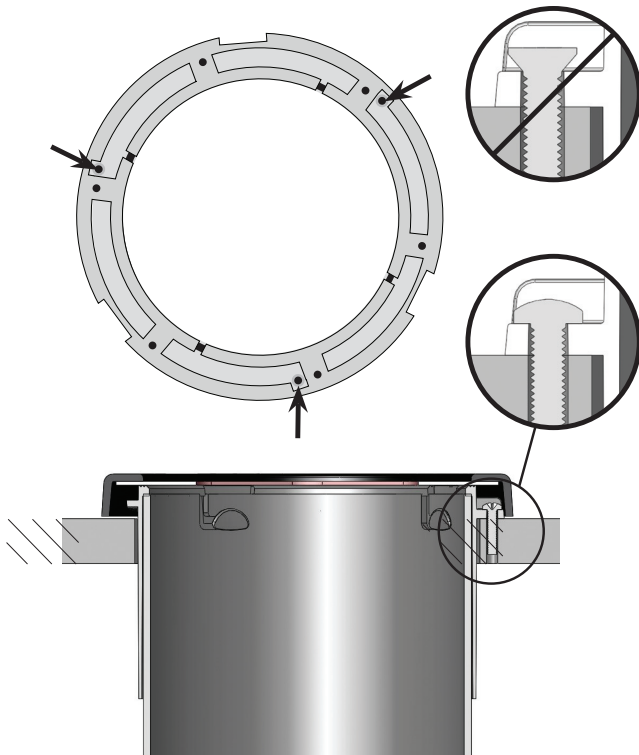

4. SELECT PROPER SIZE GASKET FOR CUP (SEE TABLE ON BACK)

5. INSTALL GASKET OVER POSTS IN UNDERSIDE OF RING

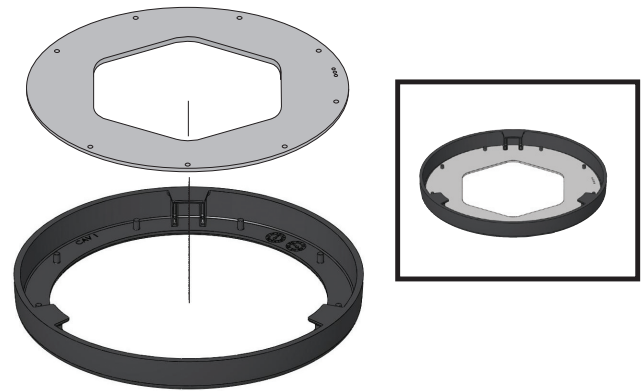

6. REPLACE COVER RING WITH GASKET BY TURNING CLOCKWISE OVER MOUNTING RING UNTIL SECURE

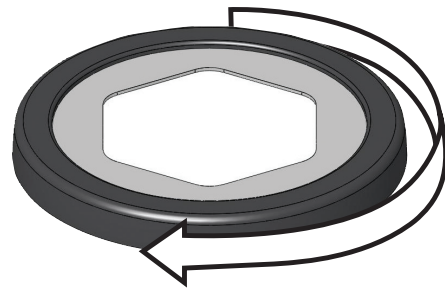

7. LOAD CUPS THROUGH GASKET

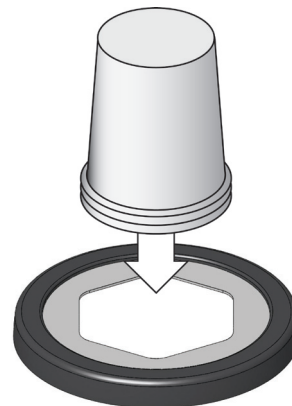

REPLACEMENT PARTS & ACCESSORIES

C2509 Black Mounting Ring
C2518 Gray Trim Ring

C2516V Spring End Cap
C2513 End Cap
C2526 Cup Pusher

XC2522S Small Gasket
XC2522M Medium Gasket
XC2522L Large Gasket

GASKET SIZING GUIDE

APPROXIMATE CUP RIM DIAMETER		GASKET SIZE	PART NUMBERS (Packs of 3)
minimum	maximum		
4 1/2" (114mm)	4 3/4" (121mm)	SMALL	XC2522S
4 13/16" (122mm)	5 1/8" (130mm)	MEDIUM	XC2522M
5 3/16" (131mm)	5 5/8" (143mm)	LARGE	XC2522L

1. TURN CUP UPSIDE DOWN ON RULER, WITH WIDEST POINT OF RIM TOUCHING END OF RULER (BLACK DOT).

2. DETERMINE SIZE OF CUP RIM DIAMETER (S, M, L, XL) BASED ON PLACEMENT OF RIGHT SIDE OF CUP.

3. USE GASKET FOR THAT SIZE.

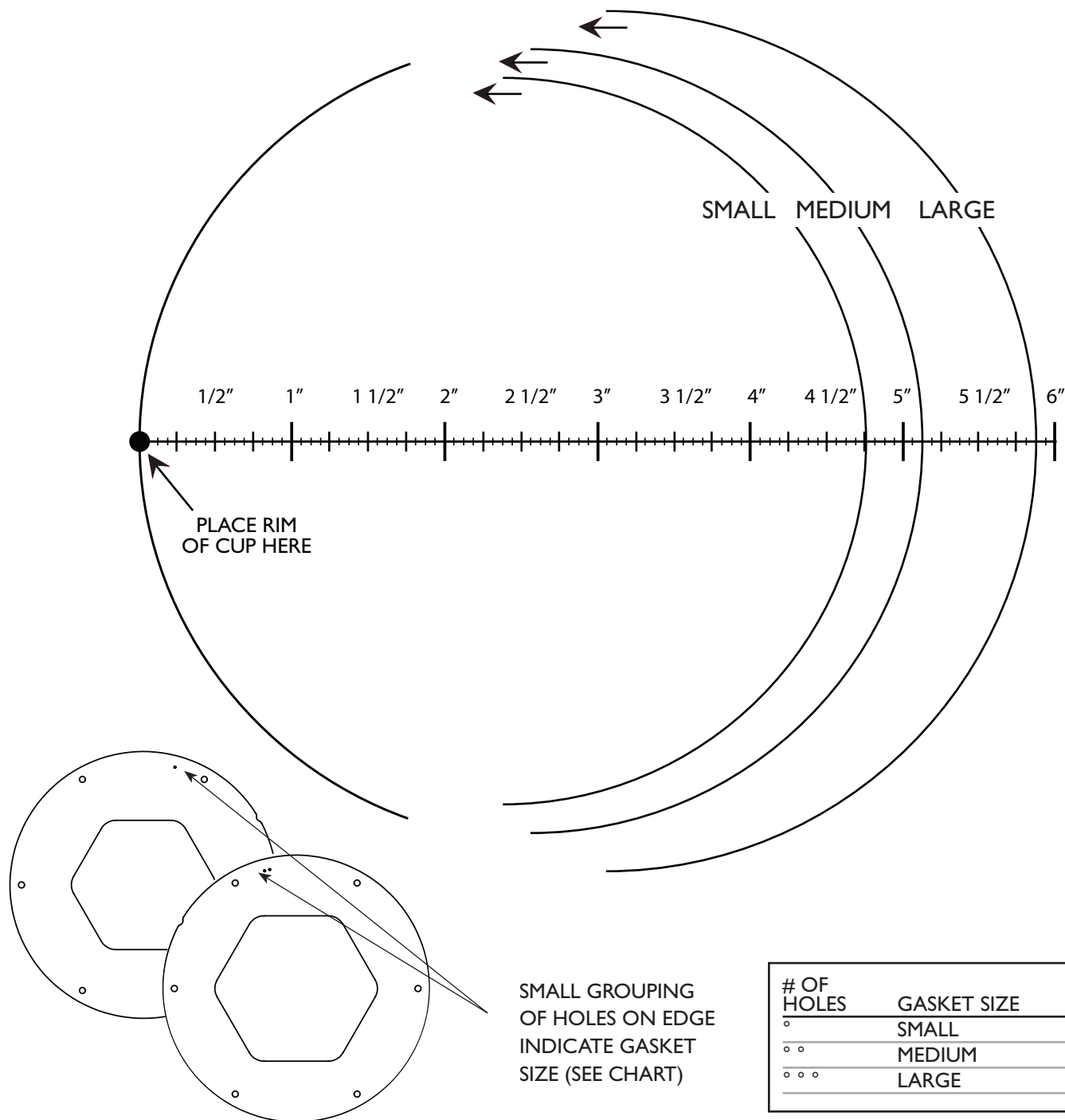

# OF HOLES	GASKET SIZE	PART #
○	SMALL	XC2522S
○ ○	MEDIUM	XC2522M
○ ○ ○	LARGE	XC2522L

San Jamar
 Chef Revival
 555 Koopman Lane
 Elkhorn, Wisconsin 53121
 USA
 T: +1.262.723.6133
 F: +1.262.723.4204
 info@sjcr.com

SJCR Canada
 3300 Bloor Street West
 Center Tower, 11th Floor, Suite 3140
 Toronto, ON M8X 2X3
 CANADA
 T: +1.416.760.7367
 F: +1.416.207.2071
 canada@sjcr.com

SJCR Europe
 Schoorstraat 26A, bus-1
 2220 Heist op-den Berg
 BELGIUM
 T: +32 1522 8140
 F: +32 1522 8148
 emea@sjcr.com

SJCR México
 Av. Universidad #1377-701
 Colonia Axotla CP 01030
 Del. Álvaro Obregón
 MÉXICO, DF
 T: +52 (55) 3626 0772
 F: +52 (55) 5273 4495
 mexico@sjcr.com

SAN JAMAR
 Smart ♦ Safe ♦ Sanitary