

ELECTRICAL

MODEL	VOLTS	WATTS	AMPS	PHASE	FIELD WIRING GAUGE	TEMP. RATING
SS-8T	120	825	6.9	SINGLE	14 AWB Cu	90°C
SS-8T	208	620	3.0	SINGLE	14 AWB Cu	90°C
SS-8T	240	825	3.4	SINGLE	14 AWB Cu	90°C
SS-8TD	120	825	6.9	SINGLE	14 AWB Cu	90°C
SS-8TD	208	620	3.0	SINGLE	14 AWB Cu	90°C
SS-8TD	240	825	3.4	SINGLE	14 AWB Cu	90°C

INSTALLATION INSTRUCTIONS BUILT-IN ROUND FOOD WARMERS MODELS SS-8T (D)

CLEARANCES

SUGGESTED CLEARANCES FROM
UNIT TO THE NEAREST SURFACE

BACK	SIDE	BOTTOM	FRONT
$\frac{1}{(25)}$	$\frac{1}{(25)}$	$\frac{8\ 1/2}{(216)}$	$\frac{4}{(102)}$

INCHES
(MM)

SEE CONDITIONS OF ACCEPTABILITY BELOW

WHEN CONTROL BOX IS LOCATED BELOW THE
UNIT, FRONT CLEARANCE CAN BE 2 INCHES.

NOTE: DEPENDING ON THE INSTALLATION,
CLEARANCES CAN BE CHANGED UPON
FURTHER EVALUATIONS TO UL STANDARDS.

CUTOUT DETAILS

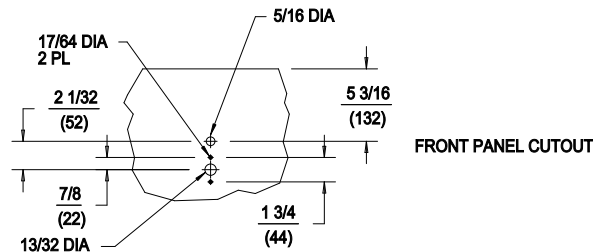
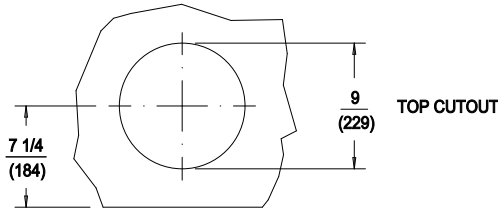

PRODUCT DIMENSIONS

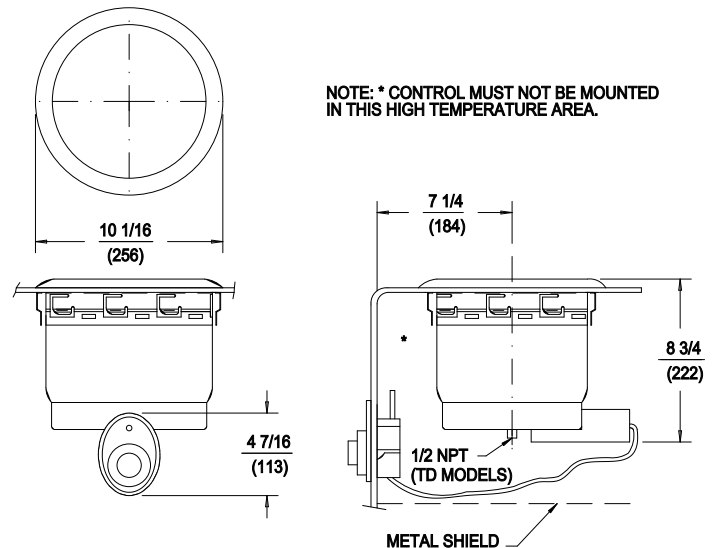

INSTALLATION INSTRUCTIONS

UNIT MUST BE INSTALLED IN AN ALL METAL COUNTER.

THE INSTALLATION OF RECOGNIZED COMPONENT UNITS
REQUIRES ADDITIONAL EVALUATIONS TO UNDERWRITERS
LABORATORIES INC. STANDARDS.

INSTALLER MUST MEET CONDITIONS OF ACCEPTABILITY
OUTLINED BELOW UPON INSTALLATION:

1. This appliance shall be installed in an all metal counter with suitable wiring and control enclosures conforming to national and local electrical codes.
2. Electrical component temperatures, including wiring, within and surrounding the appliance must be monitored in the end use installation for suitability.
3. Electrical grounding of all dead metal parts must be reliably connected to the grounding means of the appliance and must comply with the requirements outlined in the appropriate Underwriters Laboratories Inc. classification, national and local electrical codes.
4. Increased clearances are required if storage of combustible materials is in close proximity to this appliance.
5. Unit shall be accessible for servicing from the bottom.
6. The name/rating plate information shall be accessible.
7. For water and waste connections: This appliance is to be installed to comply with the applicable federal, state or local plumbing codes.

TO FABRICATE:

1. Lay out "cutout" dimensions on countertop and front apron as shown in cutout details above.
2. Cut and/or drill holes as required in countertop and apron
3. Must be accessible for servicing from the bottom.

TO INSTALL:

IMPORTANT - DO NOT disconnect lead wires from the Control Panel when installing.

1. Locate the warmer and control panel over the countertop cutout. Pass the control through the opening, then mount the control to the rear of the apron.
2. Apply a bead of silicone adhesive/sealant to the gasket supplied on the underside of the warmer flange, then seat the warmer onto the countertop. Properly position.
3. From underneath, insert a screwdriver into the "slots" on the wellslok frame and twist the "ears" outward to secure the flange tightly to the countertop (see detail).
4. Mount the master control panel to the front of the counter apron using the screws supplied.

