

# **STAR<sup>®</sup>** **TWO SIDED GRILLS**

MODEL  
GX10IG, IS, ISG  
GX14IG, IS, ISG  
GX20IG, IS, IGS

## **Installation and Operation Instructions**

2M-Z7971 Rev. J 9/22/2010

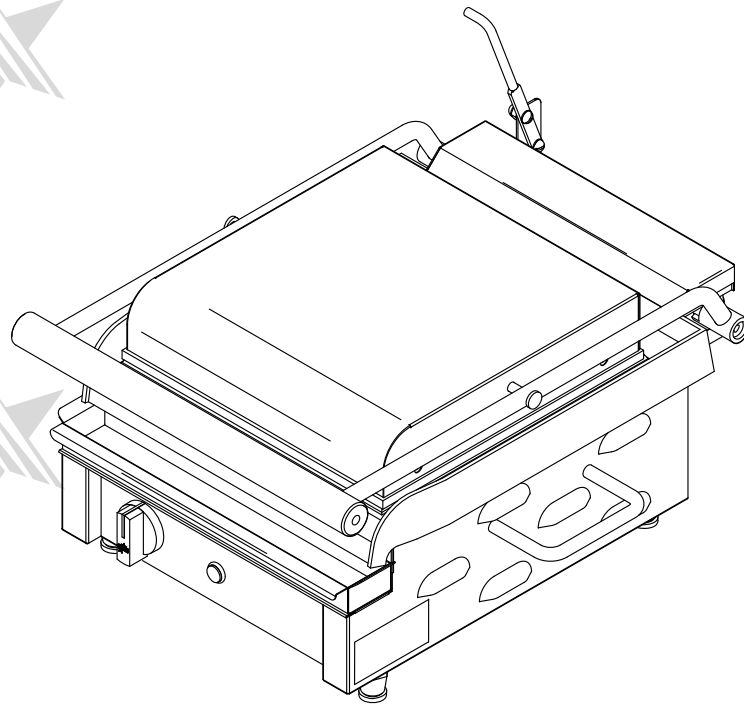

GX10IG



## SAFETY SYMBOL



These symbols are intended to alert the user to the presence of important operating and maintenance instructions in the manual accompanying the appliance.

---

## RETAIN THIS MANUAL FOR FUTURE REFERENCE NOTICE

Using any part other than genuine Star factory supplied parts relieves the manufacturer of all liability.

Star reserves the right to change specifications and product design without notice. Such revisions do not entitle the buyer to corresponding changes, improvements, additions or replacements for previously purchased equipment.

Due to periodic changes in designs, methods, procedures, policies and regulations, the specifications contained in this sheet are subject to change without notice. While Star International Holdings Inc., Company exercises good faith efforts to provide information that is accurate, we are not responsible for errors or omissions in information provided or conclusions reached as a result of using the specifications. By using the information provided, the user assumes all risks in connection with such use.

## MAINTENANCE AND REPAIRS

Contact your local authorized service agent for service or required maintenance.

Please record the model number, serial number, voltage and purchase date in the area below and have it ready when you call to ensure a faster service.

Model No. \_\_\_\_\_  
Serial No. \_\_\_\_\_  
Voltage \_\_\_\_\_  
Purchase Date \_\_\_\_\_

### Authorized Service Agent Listing

Reference the listing provided with the unit

or

for an updated listing go to:

**Website:** [www.star-mfg.com](http://www.star-mfg.com)  
**E-mail** [customerservice@star-mfg.com](mailto:customerservice@star-mfg.com)

### Service Help Desk

**Business Hours:** 8:00 am to 4:30 p.m. Central Standard Time

**Telephone:** (314) 678-6303

**Fax:** (314) 781-2714

**E-mail** [customerservice@star-mfg.com](mailto:customerservice@star-mfg.com)

**Website:** [www.star-mfg.com](http://www.star-mfg.com)

**Mailing Address:** Star International Holdings Inc., Company  
10 Sunnen Drive  
St. Louis, MO 63143  
U.S.A

## GENERAL INSTALLATION DATA



### CAUTION

This equipment is designed and sold for commercial use only by personnel trained and experienced in its operation and is not sold for consumer use in and around the home nor for use directly by the general public in food service locations.

All shipping containers should be checked for freight damage both visible and concealed. This unit has been tested and carefully packaged to insure delivery of your unit in perfect condition. If equipment is received in damaged condition, either apparent or concealed, a claim must be made with the delivering carrier.

Concealed damage or loss - if damage or loss is not apparent until after equipment is unpacked, a request for inspection of concealed damage must be made with carrier within 15 days. Be certain to retain all contents plus external and internal packaging materials for inspection. The carrier will make an inspection and will supply necessary claim forms.

## VENTILATION AND CLEARANCES

The installation of any components such as a vent hood, grease extractors, and/or fire extinguishing systems, must conform to their applicable nationally recognized installation standards and/or local building codes.

## ELECTRICAL CONNECTION

Before making any electrical connection be sure to read data plate which is located at the bottom of the unit.

## ELECTRICAL GROUNDING INSTRUCTIONS

This unit is equipped with a 3-prong (grounding) plug for your protection against shock hazard and must be plugged directly into a properly grounded 3-prong receptacle.

**DO NOT CUT OR REMOVE THIS PLUG OR GROUNDING PRONG FROM THE PLUG.**



### WARNING

**CONNECT/PLUG UNIT INTO DEDICATED A.C. LINE ONLY SPECIFIED ON THE DATA PLATE OF THE UNIT.**

ELECTRICAL SPECIFICATIONS				
Model	Voltage	Rated Wattage	Amps	Plug
GX10IG	120V	1,400	11.7	NEMA 5-15P
	230V	1,650	7.2	BS 1363A (16amp)
	208/240V	1,350 / 1,800	6.5 / 7.5	NEMA 6-15P
GX10IS	120V	1,400	11.7	NEMA 5-15P
	230V	1,650	7.2	BS 1363A (16amp)
	208/240V	1,350 / 1,800	6.5 / 7.5	NEMA 6-15P
GX10ISG	120V	1,400	11.7	NEMA 5-15P
	230V	1,650	7.2	BS 1363A (16amp)
	208/240V	1,350 / 1,800	6.5 / 7.5	NEMA 6-15P
GX14IG	120V	1,800	15	NEMA 5-15P
	230V	2,570	11.2	BS 1363A (16 amp)
	208/240V	2,100 / 2,800	10.1 / 11.7	NEMA 6-15P
GX14IS	120V	1,800	15	NEMA 5-15P
	230V	2,570	11.2	BS 1363A (16 amp)
	208/240V	2,100 / 2,800	10.1 / 11.7	NEMA 6-15P
GX14ISG	120V	1,800	15	NEMA 5-15P
	230V	2,570	11.2	BS 1363A (16 amp)
	208/240V	2,100 / 2,800	10.1 / 11.7	NEMA 6-15P
GX20IG	208/240V	2,700 / 3,600	13 / 15	NEMA 6-20P
	230V	3,300	14.4	BS 1363A (16 amp)
GX20IGS	208/240V	2,700 / 3,600	13 / 15	NEMA 6-20P
	230V	3,300	14.4	BS 1363A (16 amp)
GX20IS	208/240V	2,700 / 3,600	13 / 15	NEMA 6-20P
	230V	3,300	14.4	BS 1363A (16 amp)



**CONNECT/PLUG UNIT INTO DEDICATED A.C. LINE ONLY SPECIFIED ON THE DATA PLATE OF THE UNIT.**

#### **INITIAL START UP**

Level unit using the adjustable feet under the unit (approximately 1/2" adjustment).

Before using the unit for the first time, wipe down the exterior and grilling area with a damp cloth. Take to a well ventilated area and heat for approximately 30 minutes. The grill may emit a small amount of smoke as the cooking surfaces reaches 450°F. Do not be alarmed, as the smoke is caused by oils associated with the manufacturing process and will stop when the burn off is complete. Brush off any debris from the grilling surface.

#### **SEASONING THE COOKING SURFACES**

The cooking surfaces must be "seasoned" in order to reduce product sticking. To season, bring grill to 300°F, until completed. Brush upper and lower cooking surfaces with a **salt free** liquid vegetable oil. If using an aerosol agent, first apply into a cup and then brush onto cooking surface. Let sit for 20 minutes, and then wipe clean using a warm damp cloth. Repeat if required.

#### **SETTING THE TEMPERATURE**

The thermostat control knob is used to set the temperature to your requirements. The maximum set point is 450°F (232°C), the minimum set point is 175°F (79°C). See Knob Settings.

#### **DAILY OPERATION**

Check the power cord to insure that it is plugged into a proper outlet.

Check that the thermostat control is turned on.

The pilot light will come on when the thermostat control goes past the 175°F.

Set the thermostat control knob to desired temperature.

Always allow 20 minutes of preheat time before loading the unit with product.

Failure to allow sufficient preheat time will result in unsatisfactory cooking of the first load.

## OPERATING HINTS AND SAFETY

Disconnect power to the unit with the switch at the end of each day of operation.

Do not leave the unit in operation without an attendant.

Turn thermostat down to 200°F (93°C) during idle periods. It will take only a few minutes to regain operating temperature.

Use spatula to push excess grease into grease cup after each load of food is cooked.

This will reduce smoking of hot grease and carbonizing.

Do not leave the unit at high temperature when not in use or during idle periods.

This will cause food particles and grease film to carbonize.

"Season" cooking surfaces with non-salted vegetable oil to reduce product sticking.

## MONTHLY LUBRICATION/INSPECTION

Apply two (2) drops of non-toxic mineral or vegetable oil to hinge bracket at the rear.

Check the bolts, screws and nuts, tighten if necessary.

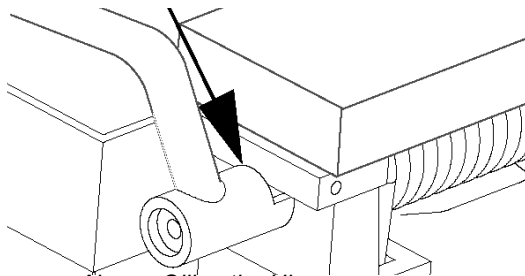

Above: Oiling the Hinge,  
Below: Tightening the top housing

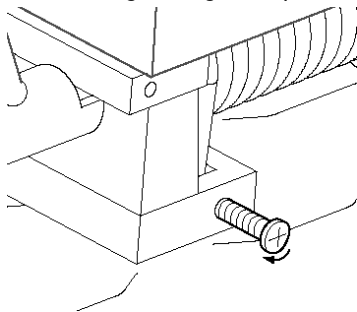

## TOP HOUSING MAINTENANCE

The Spring setting which holds the top housing in the up position is set at the factory and should provide many years of use without the need of adjusting.

After an extended period of time the top housing may not maintain its original setting, therefore the spring tension can be adjusted by tightening and loosening the Retainer bolts on the back of the unit.

## CLEANING

While holding top lid with one hand, apply only cleaners which are safe for aluminum **and iron surfaces**. **Wipe with clean sponge or towel until unit is clean.**

1. If particles adhere to the cooking surface during the day, scrape them off with a spatula or stiff brush.

**NOTE:** It is best not to let food cook on to the grill, as build up of food on the grill will increase sticking and smoking. In addition, carbon may build up on the grill surface and reduce the cooking efficiency.

2. At the end of the day, wipe down all surfaces with a warm, damp cloth, use a mild detergent on all non-cooking areas and then dry entire unit.
3. Remove and empty to clean grease catcher cup as required using mild detergent and water.

## CLEANING CARBON BUILDUP

1. When carbon build up occurs, use a carbon removal agent to clean cooking surface. When this process is completed, you must re-season the grill (See Seasoning Grill).
2. Acidic cleaners are NOT recommended as a cleaning agent.



**DO NOT IMMERSE OR LET THE UNIT STAND IN WATER.**

**DO NOT HOSE DOWN THE UNIT OR THE TABLE/COUNTER IF THE UNIT IS ON THE TABLE/COUNTER.**

**KEEP AWAY FROM RUNNING WATER.**

## CLEANING cont



**CAUTION**

**DO NOT USE SHARP OBJECTS TO REMOVE CARBON BUILD-UP.  
BEFORE CLEANING MAKE SURE POWER IS TURNED OFF, UNIT IS  
UNPLUGGED AND IS NOT TOO HOT.**



**WARNING**

**DO NOT SPLASH WATER ON FRONT CONTROL PANEL!  
DO NOT SPLASH WATER ON FLEX CONDUIT CONNECTING TOP AND  
BOTTOM OF THE UNIT.**



**WARNING**

Do not use ice or cold water to clean the cooking surfaces when the unit is hot. The surfaces are cast aluminum or cast iron and may crack or deform under the shock of rapid temperature change.

## OPERATION TROUBLESHOOTING

### 1. Unit not heating.

- A. Check if unit is plugged in correct receptacle.
- B. Check incoming power line.
- C. Check that thermostat is set to proper temperature.

If unit still does not operate contact the factory or one of its representatives or a local service company for service or required maintenance.

### THOROUGHLY INSPECT YOUR UNIT ON ARRIVAL

This unit has been tested for proper operation before leaving our plant to insure delivery of your unit in perfect condition. However, there are instances in which the unit may be damaged in transit. In the event you discover any type of damage to your product upon receipt, you must immediately contact the transportation company who delivered the item to you and initiate your claim with same. If this procedure is not followed, it may affect the warranty status of the unit.

### LIMITED EQUIPMENT WARRANTY

All workmanship and material in Star products have a one (1) year limited warranty on parts & labor in the United States and Canada. Such warranty is limited to the original purchaser only and shall be effective from the date the equipment is placed in service. Star's obligation under this warranty is limited to the repair of defects without charge, by the factory authorized service agency or one of its sub-agencies. Models that are considered portable (*see below*) should be taken to the closest Star service agency, transportation prepaid.

- > Star will not assume any responsibility for loss of revenue.
- > On all shipments outside the United States and Canada, see International Warranty.
- \* The warranty period for the Ultra-Max, Hot Plates, Griddles, Charbroilers is (3) years parts & labor.
- \* The warranty period for the Star-Max, Charbroilers, Griddles, Hot Plates, Fryers & Finishing Oven is (2) years parts & labor.
- \* The warranty period for the JetStar six (6) ounce & Super JetStar eight (8) ounce series popcorn machines is two (2) years.
- \* The warranty period for the Chrome-Max Griddles is five (5) years on the griddle surface. See detailed warranty provided with unit.
- \* The warranty period for Dura-Tec coatings is one year under normal use and reasonable care. This warranty does not apply if damage occurs to Dura-Tec coatings from improper cleaning, maintenance, use of metallic utensils, or abrasive cleaners, abrasive pads, product identifiers and point-of-sale attachments, or any other non-food object that comes in continuous contact with the roller coating. This warranty does not apply to the "non-stick" properties of such materials.
- > This warranty does not apply to "Special Products" but to regular catalog items only. Star's warranty on "Special Products" is six (6) months on parts and ninety (90) days on labor.
- > This warranty does not apply to any item that is disassembled or tampered with for any purpose other than repair by a Star Authorized Service Center or the Service Center's sub-agency.
- > This warranty does not apply if damage occurs from improper installation, misuse, wrong voltage, wrong gas or operated contrary to the Installation and Operating instructions.
- > This warranty is not valid on Conveyor Ovens *unless* a "start-up/check-out" has been performed by a Factory Authorized Technician.

### PARTS WARRANTY

Parts that are sold to repair out of warranty equipment are warranted for ninety (90) days. The part only is warranted, the labor to replace the part is **NOT** warranted.

### SERVICES NOT COVERED BY WARRANTY

1. Travel time and mileage rendered beyond the 50 mile radius limit
2. Mileage and travel time on portable equipment (*see below*)
3. Labor to replace such items that can be replaced easily during a daily cleaning routine, ie; removable kettles on fryers, knobs, grease drawers on griddles, etc.
4. Installation of equipment
5. Damages due to improper installation
6. Damages from abuse or misuse
7. Operated contrary to the Operating and Installation Instructions
8. Cleaning of equipment
9. Seasoning of griddle plates
10. Voltage conversions
11. Gas conversions
12. Pilot light adjustment
13. Miscellaneous adjustments
14. Thermostat calibration and by-pass adjustment
15. Resetting of circuit breakers or safety controls or reset buttons
16. Replacement of bulbs
17. Replacement of fuses
18. Repair of damage created during transit, delivery, & installation OR created by acts of God

### PORTABLE EQUIPMENT

Star will not honor service bills that include travel time and mileage charges for servicing any products considered "Portable" including items listed below. These products should be taken to the Service Agency for repair:

- \* The Model 510FD, 510FF Fryer.
- \* The Model 526TOA Toaster Oven.
- \* The Model J4R, 4 oz. Popcorn Machine.
- \* The Model 518CMA & 526CMA Cheese Melter.
- \* The Model 12MC & 15MC & 18MCP Hot Food Merchandisers.
- \* The Model 12NCPW & 15NCPW Nacho Chip/Popcorn Warmer.
- \* All Hot Dog Equipment **except Roller Grills & Drawer Bun Warmers.**
- \* All Nacho Cheese Warmers **except Model 11WLA Series Nacho Cheese Warmer.**
- \* All Condiment Dispensers **except the Model HPD & SPD Series Dispenser.**
- \* All Specialty Food Warmers **except Model 130R, 11RW Series, and 11WSA Series.**
- \* All QCS/RCS Series Toasters **except Model QCS3 & RCS3 Series.**
- \* All Fast Steamer Models **except Direct Connect Series.**

### ALL:

- \* Pop-Up Toasters
- \* Butter Dispensers
- \* Pretzel Merchandisers  
(Model 16PD-A Only)
- \* Pastry Display Cabinets
- \* Nacho Chip Merchandisers
- \* Accessories of any kind
- \* Sneeze Guards
- \* Pizza Ovens  
(Model PO12 Only)
- \* Heat Lamps
- \* Pumps-Manual

The foregoing warranty is in lieu of any and all other warranties expressed or implied and constitutes the entire warranty.

### FOR ASSISTANCE

Should you need any assistance regarding the Operation or Maintenance of any Star equipment; write, phone, fax or email our Service Department. In all correspondence mention the Model number and the Serial number of your unit, and the voltage or type of gas you are using.

15 AMP PLUG  
 NEMA 5-15P ON ALL 120V UNITS.  
 NEMA 6-15P ON 240V, 1,800 WATT UNITS.  
 20 AMP PLUG  
 NEMA 6-20P ON 240V, 3,600 WATT UNITS.  
 IEC 320 POWER INLET, 16 AMP RATING.  
 SEE SEPARATE SKETCH, 230V UNITS.

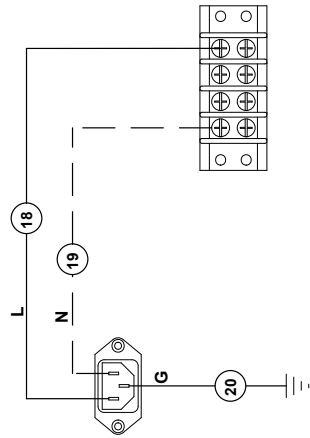

SOME ITEMS ARE INCLUDED FOR  
 ILLUSTRATIVE PURPOSES ONLY AND IN  
 CERTAIN INSTANCES MAY NOT BE AVAILABLE

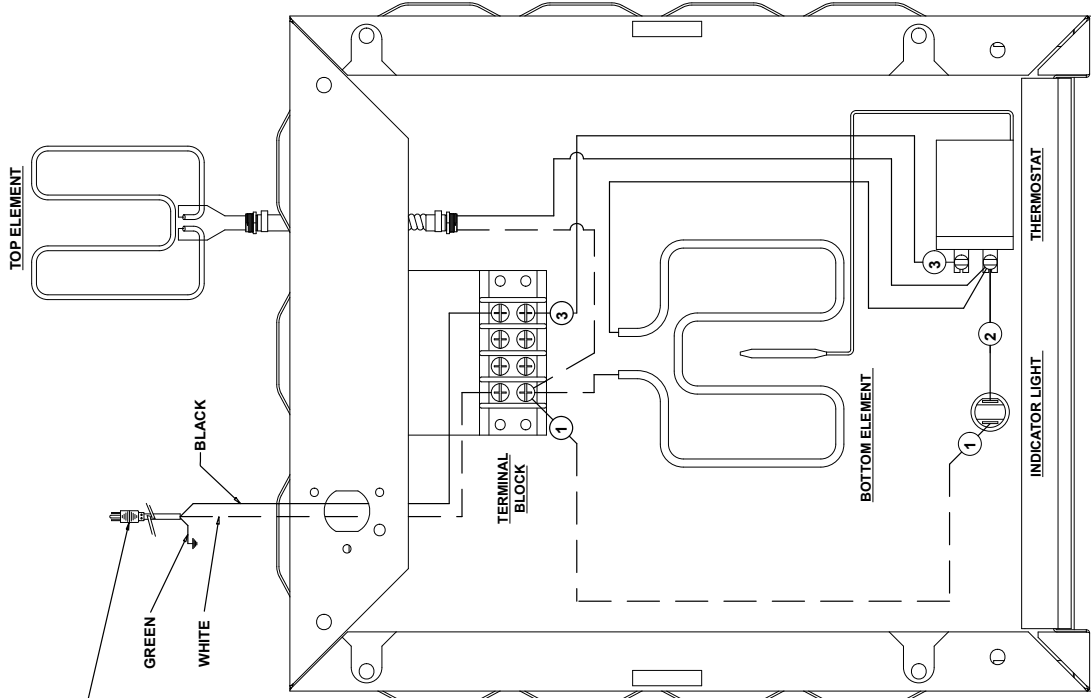

FOR REFERENCE  
 WIRING DIAGRAM IS SHOWN AS UNIT IS ASSEMBLED  
 WITH THE BOTTOM PLATE REMOVED. ITEMS ARE IN  
 GENERAL LOCATION BUT MAY BE RELOCATED OR SCALED  
 FOR CLARITY.

**MODEL: GX & PBF SINGLE LID SERIES, WIRE DIAGRAM, 120V/230/240V**

THIS DRAWING CONTAINS INFORMATION CONFIDENTIAL TO STAR MFG. INTL. INC.  
 NO REPRODUCTION OR DISCLOSURE OF ITS CONTENTS IS PERMITTED.



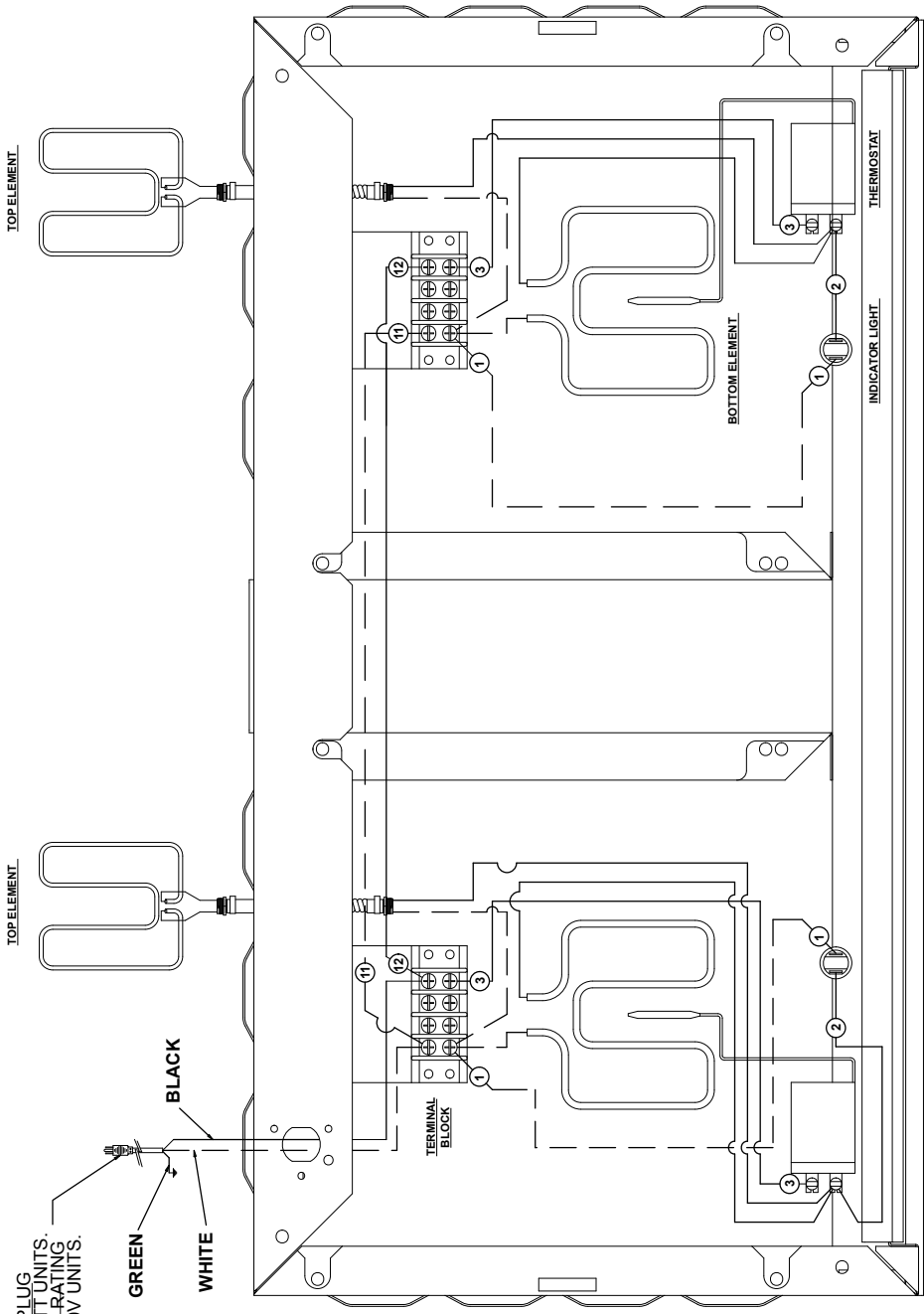

20 AMP PLUG  
 NEMA 6-20P ON 240V, 3,600 WATT UNITS.  
 IEC 320 POWER INLET, 16 AMP RATING.  
 SEE SEPARATE SKETCH, 230V UNITS.

GREEN  
 WHITE  
 BLACK

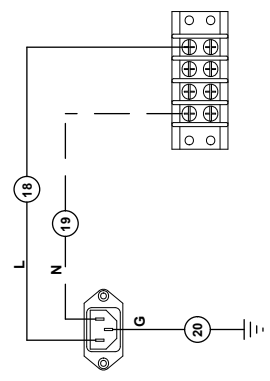

SOME ITEMS ARE INCLUDED FOR ILLUSTRATIVE PURPOSES ONLY AND IN CERTAIN INSTANCES MAY NOT BE AVAILABLE

FOR REFERENCE WIRING DIAGRAM IS SHOWN AS UNIT IS ASSEMBLED WITH THE BOTTOM PLATE REMOVED. ITEMS ARE IN GENERAL LOCATION BUT MAY BE RELOCATED OR SCALED FOR CLARITY.

**MODEL: GX & PBF DOUBLE LID SERIES, WIRE DIAGRAM, 230/240V**

THIS DRAWING CONTAINS INFORMATION CONFIDENTIAL TO STAR MFG. INTL., INC.  
 NO REPRODUCTION OR DISCLOSURE OF ITS CONTENTS IS PERMITTED.

STAR INTERNATIONAL HOLDINGS INC. COMPANY  
 SK2118 Rev - 02/16/2005

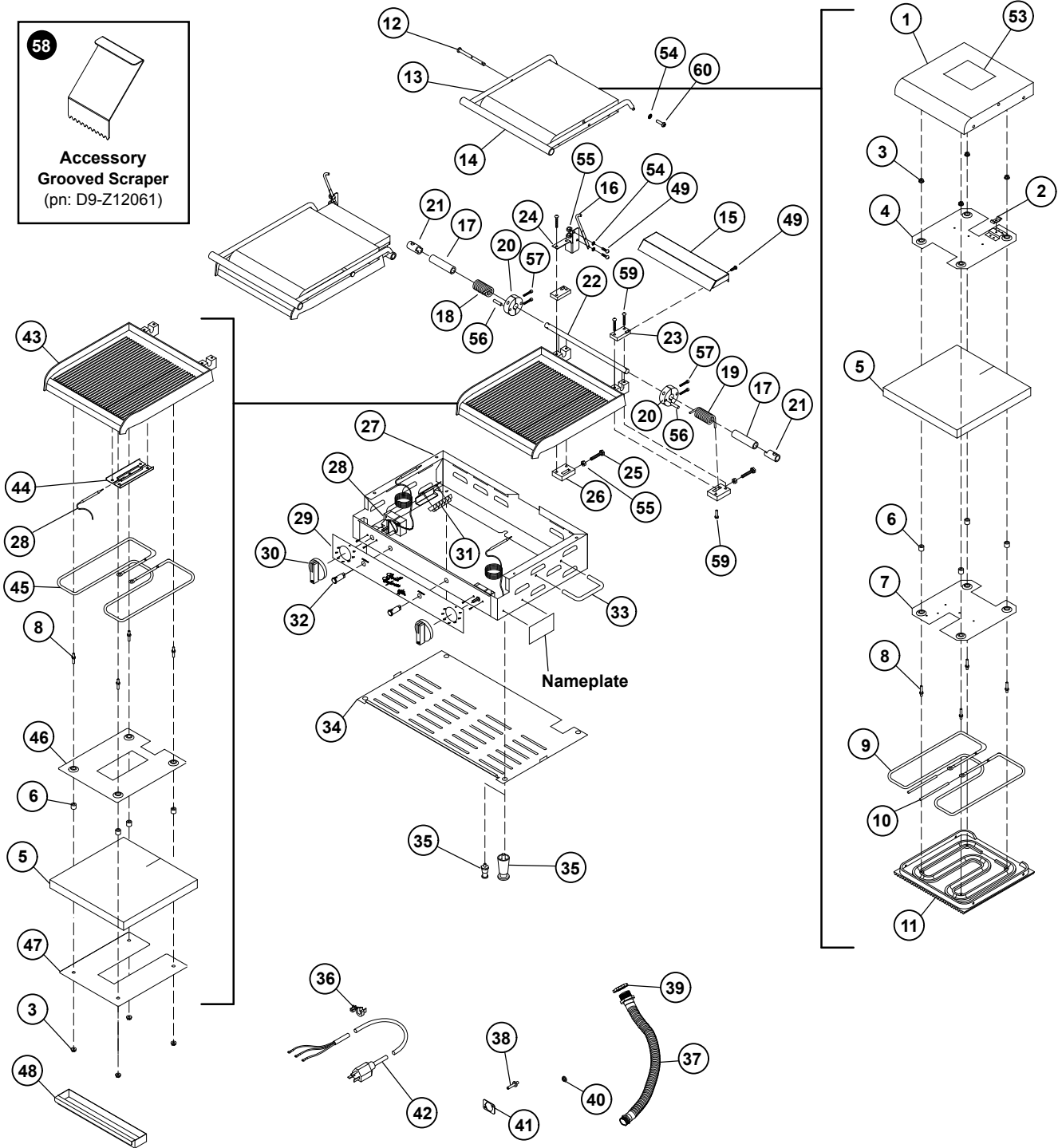
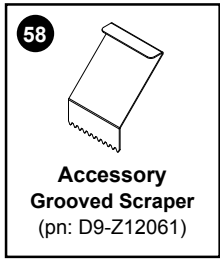

SOME ITEMS ARE INCLUDED FOR ILLUSTRATIVE PURPOSES ONLY AND IN CERTAIN INSTANCES MAY NOT BE AVAILABLE

This drawing contains information confidential to Star Manufacturing International, Inc. No reproduction or disclosure of its contents is permitted.



**MODEL GX10, GX14, GX20 SERIES**  
GX20 SHOWN

**STAR MANUFACTURING INTERNATIONAL, INC.**

SK2121 Rev. J

11/12/2014

# PARTS LIST

September 22, 2010, Rev J

## 10" TWO SIDED GRILLS

MODEL GX10IG, GX10IS, GX10ISG

Key Number	Part Number	Number Per Unit	Description
1	D9-GR0239	1	TOP HOUSING & CONDUIT - 10
2	2C-Z2054	1	CLAMP, THERMISTOR
3	2C-Z2893	8	NUT 10-24 Hex STL ZP
4	D9-GR0228	1	TOP INS. PLATE ASSY -10"
5	D9-Z2908	1	INSULATION, 10"
6	2A-Z6604	8	SPACER, INSULATION PLATE
7	D9-Z7646	1	PLATE, ELE.&INS RET. -10"
8	2C-08-07-0285	8	SCREW 10-24 x 3/4 3/8
9	PS-Z7761	1	ELEMENT, TOP, 600W, 120V-10"
	PS-Z2019	1	ELEMENT, HEATING 800W/240V
10	1O-E1500	3"	SLEEVING #4 .208ID GLASS
11	2F-Z7657	1	CASTING, IRON, TOP GR - 10"
	2F-Z7737	1	CASTING, IRON, TOP SM. -10"
12	2V-Z7641	2	ROD, ARM CONNECTION COMMON
13	2B-Z7860	2	ARM, SIDE COMMON
14	2V-Z7662	1	HANDLE -10" GRILL EXPRESS
15	D9-Z8769	1	COVER, HINGE 10
16	2V-Z3252	1	ROD - TOP HOUSING LATCH
17	2V-Z7863	2	SPACER, INSIDE 10"
18	2P-Z8824	1	SPRING, TORSION LH
19	2P-Z8823	1	SPRING, TORSION RH
20	2V-Z8407	2	COLLAR, 2 PIECE COMMON
21	2V-Z7862	2	SPACER, OUTSIDE COMMON
22	2V-Z7861	1	ROD, HINGE 10"
23	2F-Z8529	2	RETAINER, HANDLE COMMON
24	D9-Z8444	1	BRACKET, MTG - TOP LATCH ROD
25	2C-Z2992	2	BOLT 1/4"-20X1 PHP STL NP
26	2F-Z7910	2	RETAINER, SPRING
27	D9-GR0253	1	BODY ASSY - 10"
28	2T-Y2313	1	THERMOSTAT 118V-236V
29	2M-Z8848	1	OVERLAY EXP GRILL - 10"
30	2R-Z8847	1	KNOB, T-STAT CONTROL
31	2E-Z2894	1	TERMINAL BLOCK (304)
32	2J-Y6689	1	PILOT LIGHT 120V
	2J-Z2329	1	PILOT LIGHT 240 V
33	2V-Z8859	2	SPACER, SIDE
34	D9-Z7697	1	PLATE, BOTTOM-10"
35	2A-Z1485	4	FOOT 1" ADJUSTABLE
36	2K-Y3240	1	BUSHING HEYCO SR 17-2
37	2E-Z2898	1	CONDUIT ASSY, PTFE
38	2C-Z3917	2	RIVET, POP
39	2E-Z3768	1	LOCKNUT, CONDUIT 1/2 IN
40	2C-Z3780	2	RETAINER, CONDUIT
41	2A-Z3827	1	PLATE, STAMPING - CONDUIT
42	D9-Z8861	1	CORD SET 14/3 120V 15A
	2E-Y9251	1	CORD SET CONT EUR 16AMP
	2E-Z2770	1	CORD, POWER, 14-3, 6-15
43	2F-Z7730	1	CASTING, IRON, BOTTOM GR - 10"
	2F-Z7756	1	CASTING, IRON, BOT., SM.-10"
44	D9-GR0229	1	BRACKET ASSY, THERMOSTAT
45	2N-Z7765	1	ELEMENT, BOT, 800W, 120V-10
	2N-Z2020	1	ELEMENT, HEATING 1000W/240
46	D9-Z7677	1	ELEMENT PLATE, BOTTOM-10"
47	D9-Z7676	1	INS. PLATE, BOTTOM-10"
48	D9-Z8842	1	GREASE CUP 10"
49	2C-1512	6	SCREW 10-24X3/8 RHP STL NP
53	2M-Z2620	1	LABEL CAUTION,BI-LINGUAL
54	2C-6260	2	WASHER #10 INT STL NP
55	2C-2559	2	NUT 10-24 ACHD BR NP
56	2A-Z8408	2	PIN, SLOTTED SPRING-S.S.
57	2C-08-07-0236	4	SCREW 10-32 X 3/4 SHCS
58	D9-Z12061	-	SCRAPER-GROOVES
59	2C-Z5193	8	SCREW 10-24 X .75 PH SS
60	2C-1515	2	SCREW 10-24X.75 ST RH NP

Some items are included for illustrative purposes only and in certain instances may not be available.



Star Manufacturing International, Inc.

# PARTS LIST

September 22, 2010, Rev J

## 14" TWO SIDED GRILLS

MODEL GX14IG, GX14IS, GX14ISG

Key Number	Part Number	Number Per Unit	Description
1	D9-GR0233	1	TOP HOUSING ASSY 14" ALL
2	2C-Z2054	1	CLAMP, THERMISTOR ALL
3	2C-Z2893	8	NUT 10-24 Hex STL ZP ALL
4	D9-GR0232	1	TOP INS. PLATE ASSY -14" ALL
5	D9-Z7991	1	INSULATION, 14" ALL
6	2A-Z6604	8	SPACER, INSULATION PLATE ALL
7	D9-Z7846	1	PLATE, ELE.&INS RET. -14" ALL
8	2C-08-07-0285	8	SCREW 10-24 x 3/4 3/8 ALL
9	PS-Z7769	1	ELEMENT, TOP, 800W, 120V-14" 120 V
	PS-Z7771	1	ELEMENT, TOP, 1250W,240V-14 230/240 V
10	10-E1500	0.333	SLEEVEING #4 .208ID GLASS ALL
11	2F-Z7741	1	CASTING, IRON, TOP GR - 14" GROOVED MODELS
	2F-Z7742	1	CASTING, IRON, TOP SM. -14" SMOOTH MODELS
12	2V-Z7641	2	ROD, ARM CONNECTION COMMON ALL
13	2B-Z7860	2	ARM, SIDE COMMON ALL
14	2V-Z7992	1	HANDLE -14" GRILL EXPRESS ALL
15	D9-Z8429	1	COVER, HINGE 14 ALL
16	2V-Z3252	1	ROD - TOP HOUSING LATCH ALL
17	2V-Z7863	2	SPACER, INSIDE 10" ALL
18	2P-Z8756	1	SPRING, TORSION LH ALL
19	2P-Z8755	1	SPRING, TORSION RH ALL
20	2V-Z8407	2	COLLAR, 2 PIECE COMMON ALL
21	2V-Z7862	2	SPACER, OUTSIDE COMMON ALL
22	2V-Z7994	1	ROD, HINGE 14" ALL
23	2F-Z8529	2	RETAINER, HANDLE COMMON ALL
24	D9-Z8444	1	BRACKET, MTG - TOP LATCH ROD ALL
25	2C-Z2992	2	BOLT 1/4"-20X1 PHP STL NP ALL
26	2F-Z7910	2	RETAINER, SPRING ALL
27	D9-GR0254	1	BODY ASSY - 14" ALL
28	2T-Y2313	1	THERMOSTAT 118V-236V ALL
29	2M-Z8849	1	OVERLAY 14" EXPRESS GRILL ALL
30	2R-Z8847	1	KNOB, T-STAT CONTROL ALL
31	2E-Z2894	1	TERMINAL BLOCK (304) ALL
32	2J-Y6689	1	PILOT LIGHT 120V 120V, 120VC-CANADA
32	2J-Z2329	1	PILOT LIGHT 240 V 230/240 V
33	2V-Z8859	2	SPACER, SIDE ALL
34	D9-Z7842	1	PLATE, BOTTOM-14" ALL
35	2A-Z1485	4	FOOT 1" ADJUSTABLE ALL
36	2K-Y3240	1	BUSHING HEYCO SR 17-2 ALL
37	2E-Z2898	1	CONDUIT ASSY, PTFE ALL
38	2C-Z3917	2	RIVET, POP ALL
39	2E-Z3768	1	LOCKNUT, CONDUIT 1/2 IN ALL
40	2C-Z3780	2	RETAINER, CONDUIT ALL
41	2A-Z3827	1	PLATE, STAMPING - CONDUIT ALL
42	D9-Z8861	1	CORD SET 14/3 120V 15A 120V
	D9-Z8917	1	CORD SET 120V 5-20P 120VC-CANADA
	2E-Y9251	1	CORD SET CONT EUR 16AMP 230V
	2E-Z2770	1	CORD, POWER, 14-3, 6-15 240 V
43	2F-Z7758	1	CASTING, IRON, BOTTOM GR - 14" GROOVED MODELS
	2F-Z7757	1	CASTING, IRON, BOT., SM.-14" SMOOTH MODELS
44	D9-GR0229	1	BRACKET ASSY, THERMOSTAT ALL
45	2N-Z7772	1	ELEMENT, BOT, 1000W, 120V-14 120 V
	2N-Z7774	1	ELEMENT, BOT, 1500W,240V-14 230/240V
46	D9-Z7843	1	ELEMENT PLATE, BOTTOM-14" ALL
47	D9-Z7844	1	INS. PLATE, BOTTOM-14" ALL
48	D9-Z8843	1	GREASE CUP 14" ALL
49	2C-1512	6	SCREW 10-24X3/8 RHP STL NP ALL
53	2M-Z2620	1	LABEL CAUTION,BI-LINGUAL ALL
54	2C-6260	2	WASHER #10 INT STL NP ALL
55	2C-2559	2	NUT 10-24 ACHD BR NP ALL
56	2A-Z8408	2	PIN, SLOTTED SPRING-S.S. ALL
57	2C-08-07-0236	4	SCREW 10-32 X 3/4 SHCS ALL
58	D9-Z12061	-	SCRAPER-GROOVES ACCESSORY
59	2C-Z5193	8	SCREW 10-24 X .75 PH SS ALL
60	2C-1515	2	SCREW 10-24X.75 ST RH NP ALL



Star Manufacturing International, Inc.

# PARTS LIST

September 22, 2010, Rev J

## 20" TWO SIDED GRILLS

MODEL GX20IG, GX20IGS, GX20IS

Key Number	Part Number	Number Per Unit	Description
1	D9-GR0239	2	TOP HOUSING & CONDUIT - 10 ALL
2	2C-Z2054	2	CLAMP, THERMISTOR ALL
3	2C-Z2893	16	NUT 10-24 Hex STL ZP ALL
4	D9-GR0228	2	TOP INS. PLATE ASSY -10" ALL
5	D9-Z2908	2	INSULATION, 10" ALL
6	2A-Z6604	16	SPACER, INSULATION PLATE ALL
7	D9-Z7646	2	PLATE, ELE.&INS RET. -10" ALL
8	2C-08-07-0285	16	SCREW 10-24 x 3/4 3/8 ALL
9	PS-Z2019	2	ELEMENT, HEATING 800W/240V ALL
10	1O-E1500	0.666	SLEEVEING #4 .208ID GLASS ALL
11	2F-Z7657	1 or 2	CASTING, IRON, TOP GR - 10" GROOVED MODELS (depending on unit)
	2F-Z7737	1 or 2	CASTING, IRON, TOP SM. -10" SMOOTH MODELS (depending on unit)
12	2V-Z7641	4	ROD, ARM CONNECTION COMMON ALL
13	2B-Z7860	4	ARM, SIDE COMMON ALL
14	2V-Z7662	2	HANDLE -10" GRILL EXPRESS ALL
15	D9-Z8417	2	COVER, HINGE 10 ALL
16	2V-Z3252	2	ROD - TOP HOUSING LATCH ALL
17	2V-Z7863	4	SPACER, INSIDE 10" ALL
18	2P-Z8824	2	SPRING, TORSION LH ALL
19	2P-Z8823	2	SPRING, TORSION RH ALL
20	2V-Z8407	4	COLLAR, 2 PIECE COMMON ALL
21	2V-Z7862	4	SPACER, OUTSIDE COMMON ALL
22	2V-Z7861	2	ROD, HINGE 10" ALL
23	2F-Z8529	4	RETAINER, HANDLE COMMON ALL
24	D9-Z8444	2	BRACKET, MTG - TOP LATCH ROD ALL
25	2C-Z2992	4	BOLT 1/4"-20X1 PHP STL NP ALL
26	2F-Z7910	4	RETAINER, SPRING ALL
27	D9-GR0255	1	BODY ASSY - 20" ALL
28	2T-Y2313	2	THERMOSTAT 118V-236V ALL
29	2M-Z8850	1	OVERLAY 20" EXPRESS GRILL ALL
30	2R-Z8847	2	KNOB, T-STAT CONTROL ALL
31	2E-Z2894	2	TERMINAL BLOCK (304) ALL
32	2J-Z3157	2	PILOT LIGHT 250V AMBER ALL
33	2V-Z8859	2	SPACER, SIDE ALL
34	D9-Z7918	1	PLATE, BOTTOM-20" ALL
35	2A-Z1485	4	FOOT 1" ADJUSTABLE ALL manufactured on or before 2/4/08
	2R-200716	4	LEG, 2.5" IN METAL ALL manufactured after 2/5/08
36	2K-Y6764	1	BUSHING - STRAIN RELIEF ALL
37	2E-Z2898	2	CONDUIT ASSY, PTFE ALL
38	2C-Z3917	2	RIVET, POP ALL
39	2E-Z3768	2	LOCKNUT, CONDUIT 1/2 IN ALL
40	2C-Z3780	4	RETAINER, CONDUIT ALL
41	2A-Z3827	2	PLATE, STAMPING - CONDUIT ALL
42	2E-Z2905	1	CORD SJTO 12/3 NEMA 6-20P ALL
	2E-Y9251	1	CORD SET CONT EUR 16AMP 230V
43	2F-Z7730	1 or 2	CASTING, IRON, BOTTOM GR - 10" GROOVED MODELS (depending on unit)
	2F-Z7756	1 or 2	CASTING, IRON, BOT., SM.-10" SMOOTH MODELS (depending on unit)
44	D9-GR0229	2	BRACKET ASSY, THERMOSTAT ALL
45	2N-Z2020	2	ELEMENT, HEATING 1000W/240 ALL
46	D9-Z7677	2	ELEMENT PLATE, BOTTOM-10" ALL
47	D9-Z7676	2	INS. PLATE, BOTTOM-10" ALL
48	D9-Z8838	1	GREASE CUP 20" ALL
49	2C-1512	8	SCREW 10-24X3/8 RHP STL NP ALL
53	2M-Z2620	1	LABEL CAUTION,BI-LINGUAL ALL
54	2C-6260	4	WASHER #10 INT STL NP ALL
55	2C-2559	4	NUT 10-24 ACHD BR NP ALL
56	2A-Z8408	4	PIN, SLOTTED SPRING-S.S. ALL
57	2C-08-07-0236	8	SCREW 10-32 X 3/4 SHCS ALL
58	D9-Z12061	-	SCRAPER-GROOVES ACCESSORY
59	2C-Z5193	8	SCREW 10-24 X .75 PH SS ALL
60	2C-1515	2	SCREW 10-24X.75 ST RH NP ALL



Star Manufacturing International, Inc.





**STAR INTERNATIONAL HOLDINGS INC. COMPANY**

Star - Holman - Lang - Wells - Bloomfield - Toastmaster

10 Sunnen Drive, St. Louis, MO 63143 U.S.A.

(314) 678-6303

[www.star-mfg.com](http://www.star-mfg.com)