

# BUNN®

**FMD-3**  
**FMD DBC-3**  
**FMDA DBC-3**  
S/N FMD0013000 - UP

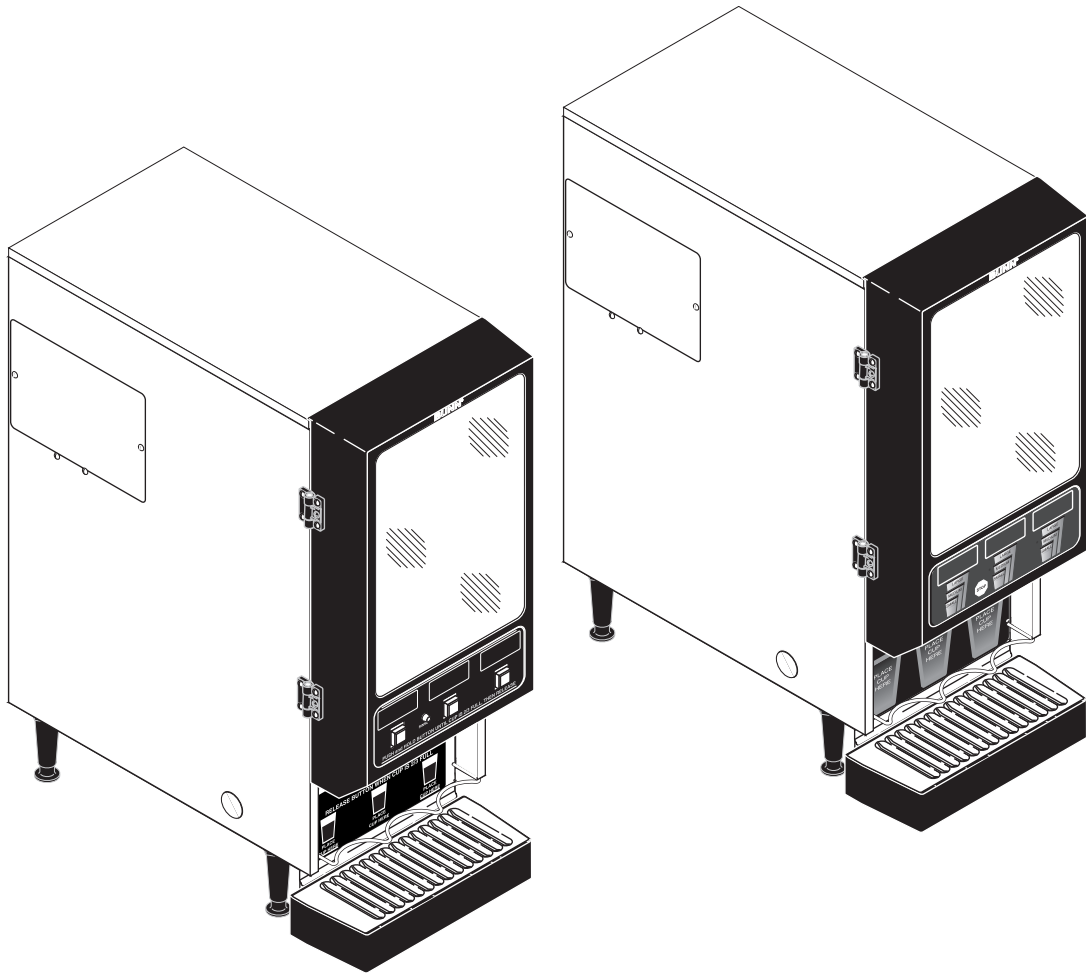

## ILLUSTRATED PARTS CATALOG

Designs, materials, weights, specifications, and dimensions for equipment or replacement parts are subject to change without notice.

**BUNN-O-MATIC CORPORATION**

POST OFFICE BOX 3227

SPRINGFIELD, ILLINOIS 62708-3227

PHONE: (217) 529-6601 FAX: (217) 529-6644



## BUNN-O-MATIC COMMERCIAL PRODUCT WARRANTY

Bunn-O-Matic Corp. ("BUNN") warrants equipment manufactured by it as follows:

- 1) Airpots, thermal carafes, decanters, GPR servers, iced tea/coffee dispensers, MCR/MCP/MCA single cup brewers, thermal servers and ThermoFresh® servers (mechanical and digital) 1 year parts and 1 year labor.
- 2) All other equipment - 2 years parts and 1 year labor plus added warranties as specified below:
  - a) Electronic circuit and/or control boards - parts and labor for 3 years.
  - b) Compressors on refrigeration equipment - 5 years parts and 1 year labor.
  - c) Grinding burrs on coffee grinding equipment to grind coffee to meet original factory screen sieve analysis - parts and labor for 4 years or 40,000 pounds of coffee, whichever comes first.

These warranty periods run from the date of installation BUNN warrants that the equipment manufactured by it will be commercially free of defects in material and workmanship existing at the time of manufacture and appearing within the applicable warranty period. This warranty does not apply to any equipment, component or part that was not manufactured by BUNN or that, in BUNN's judgment, has been affected by misuse, neglect, alteration, improper installation or operation, improper maintenance or repair, non periodic cleaning and descaling, equipment failures related to poor water quality, damage or casualty. In addition, the warranty does not apply to replacement of items subject to normal use including but not limited to user replaceable parts such as seals and gaskets. This warranty is conditioned on the Buyer 1) giving BUNN prompt notice of any claim to be made under this warranty by telephone at (217) 529-6601 or by writing to Post Office Box 3227, Springfield, Illinois 62708-3227; 2) if requested by BUNN, shipping the defective equipment prepaid to an authorized BUNN service location; and 3) receiving prior authorization from BUNN that the defective equipment is under warranty.

**THE FOREGOING WARRANTY IS EXCLUSIVE AND IS IN LIEU OF ANY OTHER WARRANTY, WRITTEN OR ORAL, EXPRESS OR IMPLIED, INCLUDING, BUT NOT LIMITED TO, ANY IMPLIED WARRANTY OF EITHER MERCHANTABILITY OR FITNESS FOR A PARTICULAR PURPOSE.** The agents, dealers or employees of BUNN are not authorized to make modifications to this warranty or to make additional warranties that are binding on BUNN. Accordingly, statements by such individuals, whether oral or written, do not constitute warranties and should not be relied upon.

If BUNN determines in its sole discretion that the equipment does not conform to the warranty, BUNN, at its exclusive option while the equipment is under warranty, shall either 1) provide at no charge replacement parts and/or labor (during the applicable parts and labor warranty periods specified above) to repair the defective components, provided that this repair is done by a BUNN Authorized Service Representative; or 2) shall replace the equipment or refund the purchase price for the equipment.

**THE BUYER'S REMEDY AGAINST BUNN FOR THE BREACH OF ANY OBLIGATION ARISING OUT OF THE SALE OF THIS EQUIPMENT, WHETHER DERIVED FROM WARRANTY OR OTHERWISE, SHALL BE LIMITED, AT BUNN'S SOLE OPTION AS SPECIFIED HEREIN, TO REPAIR, REPLACEMENT OR REFUND.**

In no event shall BUNN be liable for any other damage or loss, including, but not limited to, lost profits, lost sales, loss of use of equipment, claims of Buyer's customers, cost of capital, cost of down time, cost of substitute equipment, facilities or services, or any other special, incidental or consequential damages.

392, A Partner You Can Count On, Air Infusion, AutoPOD, AXIOM, BrewLOGIC, BrewMETER, Brew Better Not Bitter, BrewWISE, BrewWIZARD, BUNN Espresso, BUNN Family Gourmet, BUNN Gourmet, BUNN Pour-O-Matic, BUNN, BUNN with the stylized red line, BUNNlink, Bunn-OMatic, Bunn-O-Matic, BUNNserve, BUNNSERVE with the stylized wrench design, Cool Froth, DBC, Dr. Brew stylized Dr. design, Dual, Easy Pour, EasyClear, EasyGard, FlavorGard, Gourmet Ice, Gourmet Juice, High Intensity, iMIX, Infusion Series, Intellisteam, My Café, Phase Brew, PowerLogic, Quality Beverage Equipment Worldwide, Respect Earth, Respect Earth with the stylized leaf and coffee cherry design, Safety-Fresh, savemycoffee.com, Scale-Pro, Silver Series, Single, Smart Funnel, Smart Hopper, SmartWAVE, Soft Heat, SplashGard, The Mark of Quality in Beverage Equipment Worldwide, ThermoFresh, Titan, trifecta, TRIFECTA (stylized logo), Velocity Brew, Air Brew, Beverage Bar Creator, Beverage Profit Calculator, Brew better, not bitter., Build-A-Drink, BUNNSource, Coffee At Its Best, Cyclonic Heating System, Daypart, Digital Brewer Control, Element, Milk Texturing Fusion, Nothing Brews Like a BUNN, Picture Prompted Cleaning, Pouring Profits, Signature Series, Sure Tamp, Tea At Its Best, The Horizontal Red Line, Ultra are either trademarks or registered trademarks of Bunn-O-Matic Corporation. The commercial trifecta® brewer housing configuration is a trademark of Bunn-O-Matic Corporation.

## TABLE OF CONTENTS

TITLE	PAGE NO.
Auger Drive and Hopper Assembly .....	12
Covers, Panels and Drip Tray .....	4
Dispense Valves and Lines.....	22
Door, Lamp, Dispense Switches and Panels .....	8
Electrical Controls .....	24
Mixing/Whipper Chambers and Drive Motor .....	14
Numerical Index.....	28
Strainer, Solenoid, Fill Valve and Lines.....	18
Tank, Heater and Overflow Protection .....	16

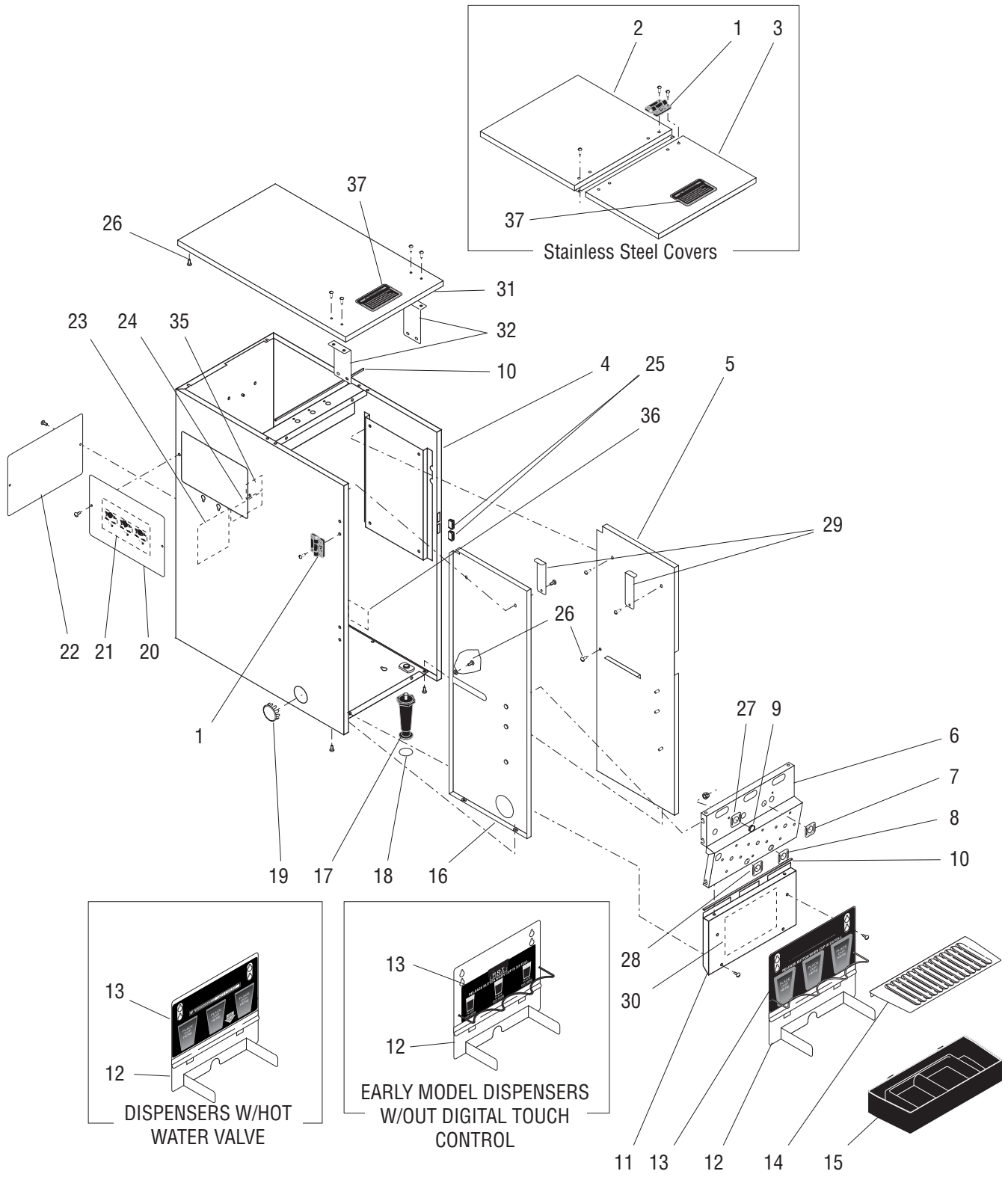

## COVERS, PANELS AND DRIP TRAY

ITEM	PART NO.	QTY.	DESCRIPTION
1	26504.0000	4	Hinge
	02308.0000	12	Screw, Pan Head #8-32 x .375"
2	28671.0000	1	Cover, Top Rear - SST
	02308.0000	2	Screw, Pan Head #8-32 x .375"
3	28670.0000	1	Cover, Top Front - SST
4	28209.1000	1	Housing W/Decals - BLK (Includes items 23 & 24)(Models w/ Horton Inlet Valve)
	28209.1001	1	Housing W/Decals - BLK (Includes items 23 & 24)(Models w/ Eltek Inlet Valve)
	28661.1000	1	Housing W/Decals - SST (Includes items 23 & 24) (Models w/ Horton Inlet Valve)
	28661.1002	1	Housing W/Decals - SST (Includes items 23 & 24) (Models w/ Eltek Inlet Valve)
	28661.0006*	1	Housing - SST 230V (Models w/ Horton Inlet Valve)
5	33886.0001	1	Panel, Right
	01311.0001	4	Screw, Truss Head - Locking #8-32 x .25"
6	28270.0000	1	Panel, Whipper Motor Mounting (Also order items 7, 8, one of item 9 & 28 - dispensers w/out cold water option, 7, 8, one of item 9, 27 & 28 - dispenser w/cold water option and 7, 8, 9 - dispensers w/digital touch control)
	28270.0001	1	Panel, Whipper Motor Mounting (Also order items 7, 8 & 9) (Used on dispensers with Hot water Valve)
	00991.0000	6	Nut, Elastic Lock #8-32
7	26524.0000	1	Decal, Tank Heater Switch
8	26523.0000	1	Decal, Rinse/Run Switch
9	00619.0010	2	Plug, Hole .437" Dia (Not used on soup dispensers or dispensers w/cold water option) (One less used on dispensers w/out digital touch control)
10	28366.0000*	2	Gasket, Foam W/Adhesive 10.1" LG (Order item 33)
11	29243.0000	1	Panel W/Decal, Lower Front Access (Includes item 30) (Dispensers w/out digital touch control)
	29243.0001	1	Panel W/Decal, Lower Front Access (Includes item 30) (Dispensers w/digital touch control)
	29243.0002	1	Panel W/Decal, Lower Front Access (Includes item 30) (Dispensers w/digital touch control and hot water valve)
	01311.0000	2	Screw, Truss Head #8-32 x .25"
12	28436.0000	1	Panel W/Decal, Splash (Includes item 13) (Dispensers w/out digital touch control)
	28436.0003	1	Panel W/Decal, Splash (Includes item 13) (Dispensers w/digital touch control)
	28436.0004	1	Panel W/Decal, Splash (Includes item 13) (Dispensers w/hot water valve)
	01311.0001	2	Screw, Truss Head - Locking #8-32 x .25"
13	-----	1	Decal, Caution-Hot Liquid & Cup Placement (Early models, order late model decal)
	29216.0002	1	Decal, Caution-Hot Liquid & Cup Placement (Late models)
	29216.0000	1	Decal, Caution-Hot Liquid & Cup Placement (Dispensers w/digital touch control)
	29216.0001	1	Decal, Caution-Hot Liquid & Cup Placement (Dispensers w/digital touch control and w/hot water valve)
14	28267.0000	1	Cover, Drip Tray
15	28268.0000	1	Drip Tray
16	33886.0000	1	Panel, Left
	01311.0001	4	Screw, Truss Head - Locking #8-32 x .25"

(Continued)

\* Indicates the part number listed is for reference only. See DESCRIPTION for possible service replacement.

(Continued)

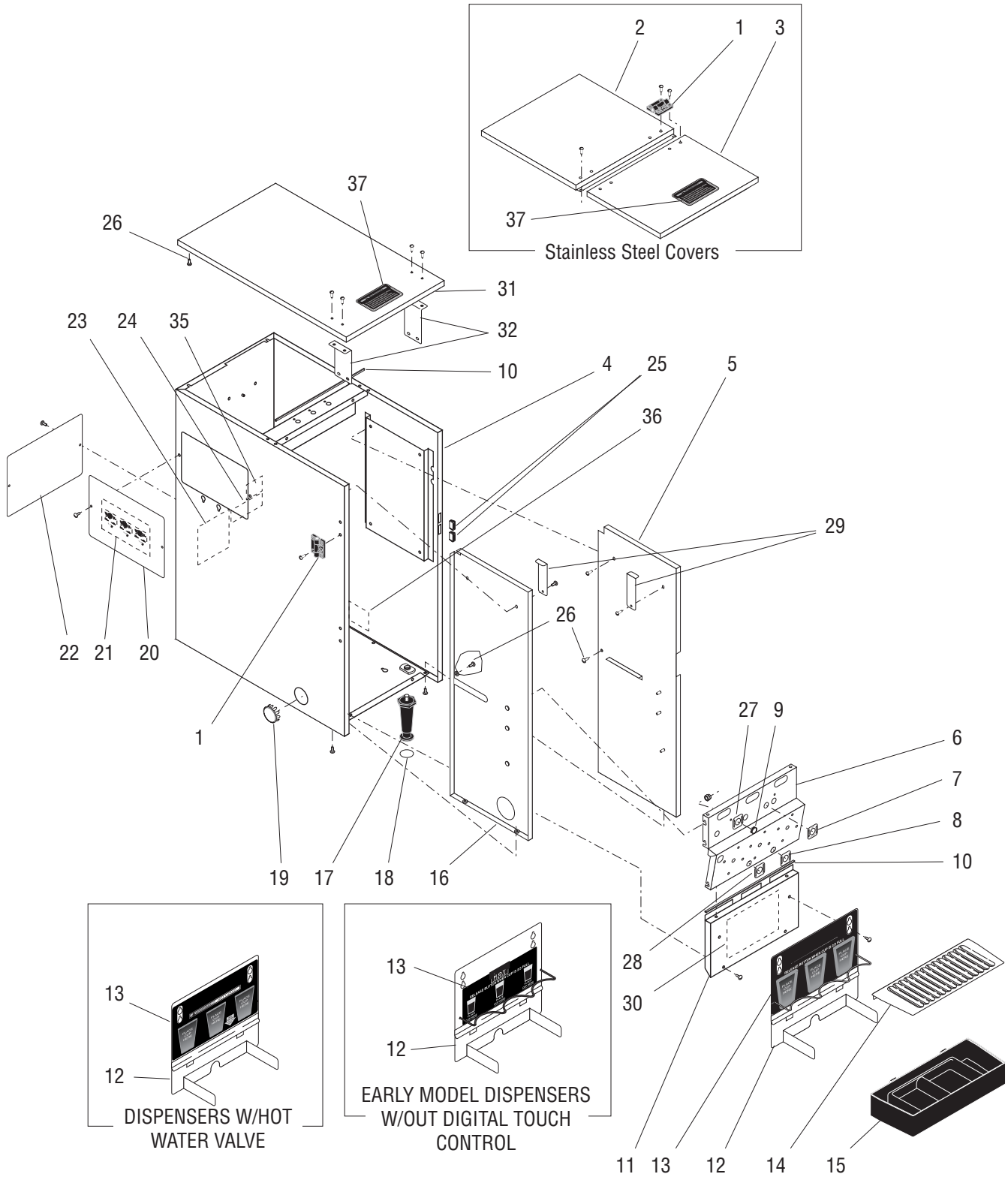

## COVERS, PANELS AND DRIP TRAY

ITEM	PART NO.	QTY.	DESCRIPTION
17	26528.0000	4	Leg, 4.0" Adjustable (Also see item 34)
18	03996.0000	4	Pad, Rubber 1.25" Dia. (Also see item 34)
19	23164.0002	1	Plug, Hole 1.50" Dia. - BLK } Early Models Plug, Hole 1.50" Dia. - SST }
	00619.0011	1	
20	28206.0000	1	Cover, Left Side Access - BLK (Also order item 21)
	28668.0000	1	Cover, Left Side Access - SST (Also order item 21)
	01311.0003	2	Screw, Truss Head - BLK #8-32 x .25"
	01311.0000	2	Screw, Truss Head - SST #8-32 x .25"
21	28368.0000	1	Decal, Thermostat Adjustment (Dispensers with Invensys mechanical thermostat)
	28368.0004	1	Decal, Thermostat Adjustment (Dispensers with Cotherm mechanical thermostat)
22	28206.0000	1	Cover, Rear Access - BLK
	28684.0000	1	Cover, Rear Access - SST
	01311.0003	2	Screw, Truss Head - BLK #8-32 x .25"
	01311.0000	2	Screw, Truss Head - SST #8-32 x .25"
23	00831.0000	1	Decal, Warning-Electrical
24	00656.0001	1	Decal, Comply to Plumbing Code
25	21436.0000	2	Catch, Magnetic
26	01311.0001	4	Screw, Truss Head - Locking #8-32 x .375"
27	26522.0000	1	Decal - HOT/COLD (Models w/cold water option)
28	28872.0000	1	Decal - INCREASE/DECREASE (Dispensers w/out digital touch control)
	26523.0000	1	Decal - RINSE/RUN (Dispensers w/digital touch control and hot water valve)
29	28910.0000	2	Bracket Kit, Cover Retainer (Includes two brackets) (Optional)
30	28874.0000	1	Schematic, 120V, 120/208V & 120/240V (Dispensers w/out digital touch control)
	29218.0000	1	Schematic, 120V, 120/208V & 120/240V (Dispensers w/digital touch control)
	29218.0002	1	Schematic, 120V (Dispensers w/digital touch control & hot water valve)
	29218.0007	-	Schematic, 230V (230V "A" Model dispensers)
31	37724.1001	1	Cover, Top - BLK (Includes item 32)
32	38053.0000	2	Bracket
	01311.0003	4	Screw, Truss Head #8-32 x .38"
33	28366.1000	-	Gasket, Foam W/Adhesive - 12" LG } Not Illustrated Gasket, Foam W/Adhesive - 36" LG } Gasket, Foam W/Adhesive - 120" LG }
	28366.1001	-	
	28366.1002	-	
34	13255.0003	-	Kit, Leg 4.0" Adjustable (Includes 4 each of items 17 & 18)
35	-----	-	Label, CE Conformity (230V "A" Model dispensers only)
36	39803.0000	1	Decal, Main ON/OFF Arrow (Models with Master ON/OFF Switch)
37	37881.0000	1	Decal, No Serviceable Parts

\* Indicates the part number listed is for reference only. See DESCRIPTION for possible service replacement.

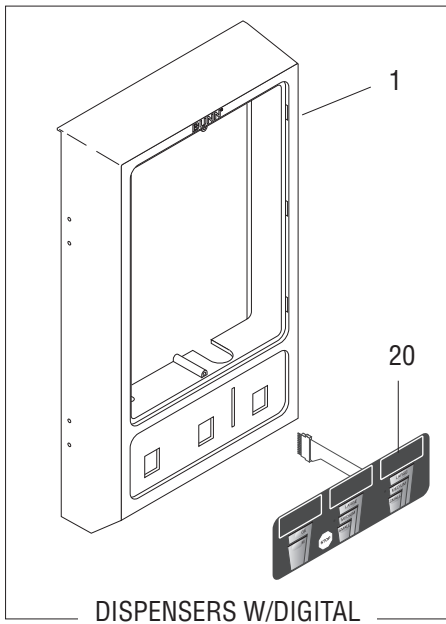
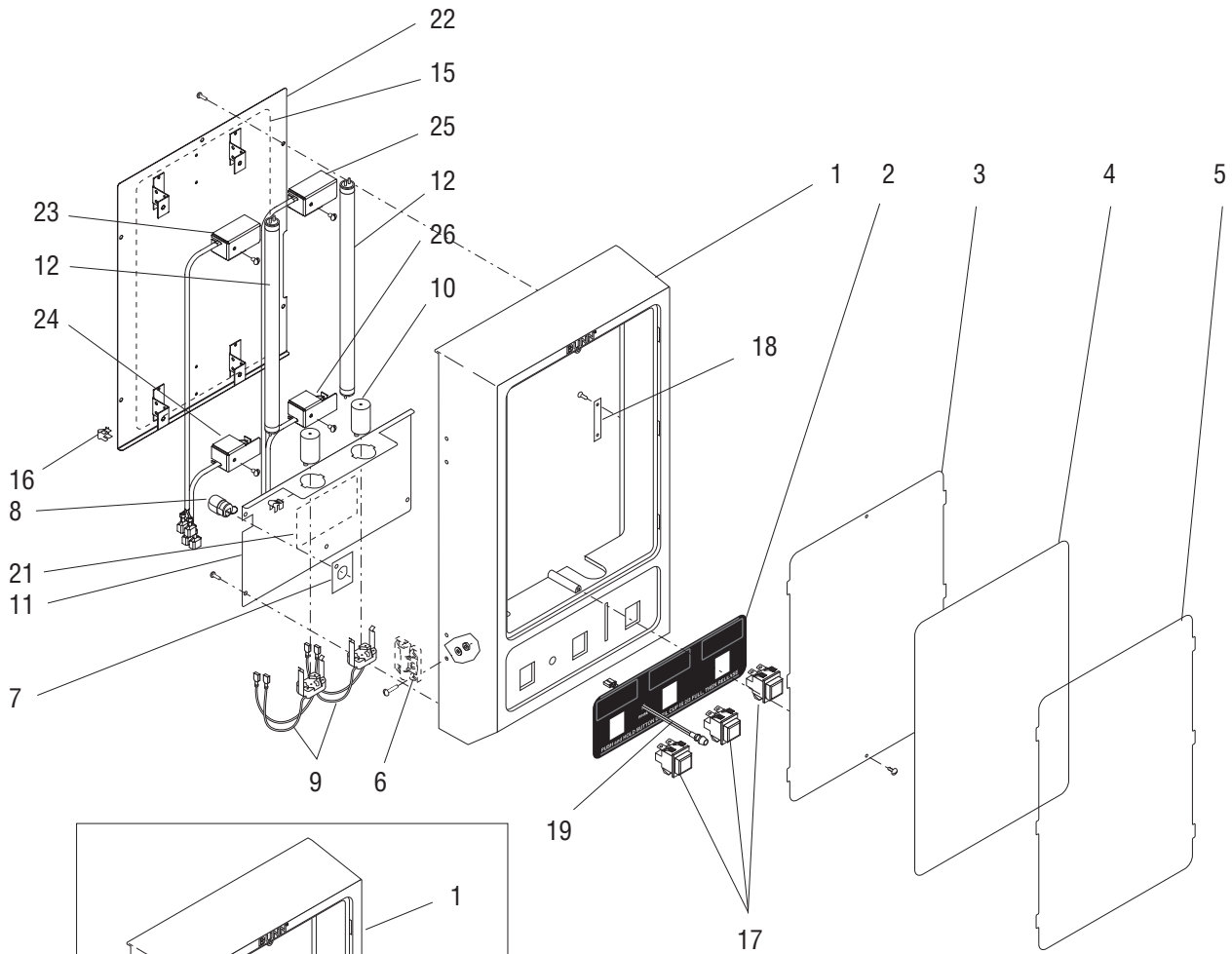

DISPENSERS W/DIGITAL TOUCH CONTROL

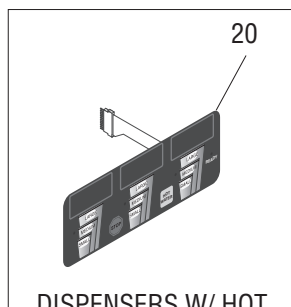

DISPENSERS W/ HOT WATER VALVE

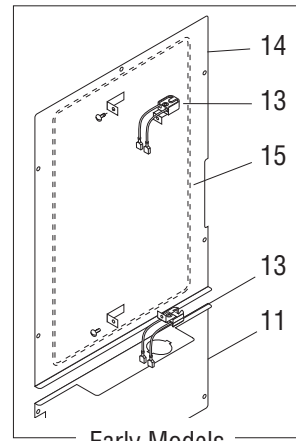

Early Models



## DOOR, LAMP, DISPENSE SWITCHES AND PANELS

ITEM	PART NO.	QTY.	DESCRIPTION
1	28147.1000	1	Door W/Decal (Includes items 2 and 18) (Dispensers w/out digital touch control)
	28147.1002	1	Door (Includes item 18) (Dispensers w/digital touch control)
	01390.0000	4	Screw, Round Head #8-32 x .625"
	01522.0000	4	Washer, Flat .203 I.D. x .50 O.D."
	00991.0000	4	Nut, Elastic Stop #8-32
2	28301.0003	1	Decal, Door Front (Dispensers w/out digital touch control)
3	38031.0001	1	Window, Door - Inside
	02336.0000	2	Screw, Truss Head #4-40 x .375"
4	28362.0000	1	Display, Graphics
	28682.0000	1	Display, Graphics (Soup)
5	38031.0000	1	Window, Door - Outside
6	-----	1	Hinge, Door (See Covers, Panels and Drip Tray)
7	26892.0000	1	Plate, Strain Relief
8	26444.0000	2	Bushing, Strain Relief
9	28325.0000	2	Socket W/Terminals, Starter 120V
	40782.0000	2	Socket W/Terminals, Starter 230V
10	27619.0000	2	Starter, Lamp
11	28261.0000	1	Panel, Door - Lower 120V (Also order item 21)(Models w/ 1 light only)
	40768.0000	1	Panel, Door - Lower 230V (Also order item 21)(Models w/ 1 light only)
	28261.0001	1	Panel, Door - Lower (Also order item 21)(Models w/ 2 lights only)
	01383.0001	5	Screw, Pan Head #6-32 x .375"
12	26239.0000	2	Lamp, Fluorescent - 8 Watts
	28322.0000	2	Lamp Holder, Fluorescent (Early Models)
13	02328.0002	2	Screw, Pan Head #6 - 32 x .188"
	28332.1000	1	Panel W/Decal, Door - Upper (Includes item 15)(Early Models)
14	01383.0001	5	Screw, Truss Head #6 - 32 x .25"
	28870.0000	1	Decal, Cleaning
16	28335.0000	2	Clip, Ground
17	28296.1000	3	Switch Assembly, Dispense (Dispensers w/out digital touch control)
18	27298.0500	1	Strike, Self Adhesive (Prior to S/N FMD0017786)
	29448.0000	1	Strike, Door
	21716.0000	2	Screw, Flat Head #6 - 32 x .25" } S/N FMD0017786 and up
19	12517.0001	1	LED W/Terminals (Dispensers w/out digital touch control)
	25292.0000	1	Lockwasher M6
	34130.0000	1	Nut M6
20	28543.0000	1	Switch, Digital Touch Control
	28543.0003	1	Switch, Digital Touch Control (Used in dispensers with Hot Water Valve)
21	29308.0000	1	Decal, Hopper Installation

(Continued)

\* Indicates the part number listed is for reference only. See DESCRIPTION for possible service replacement.

(Continued)

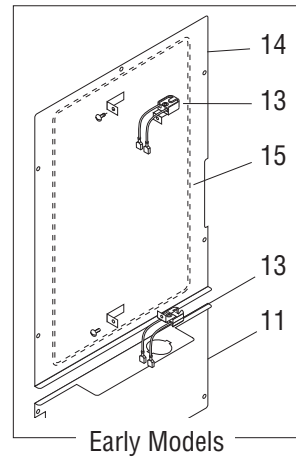
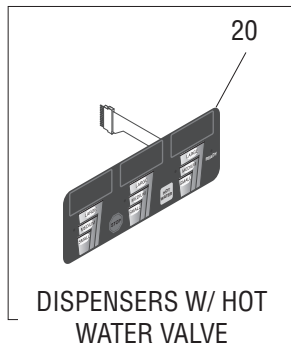
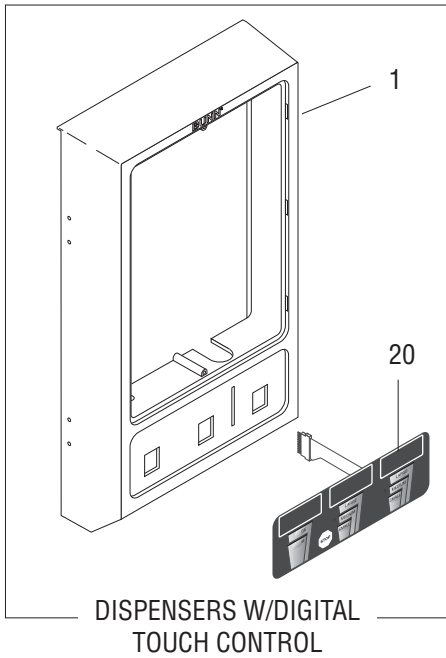
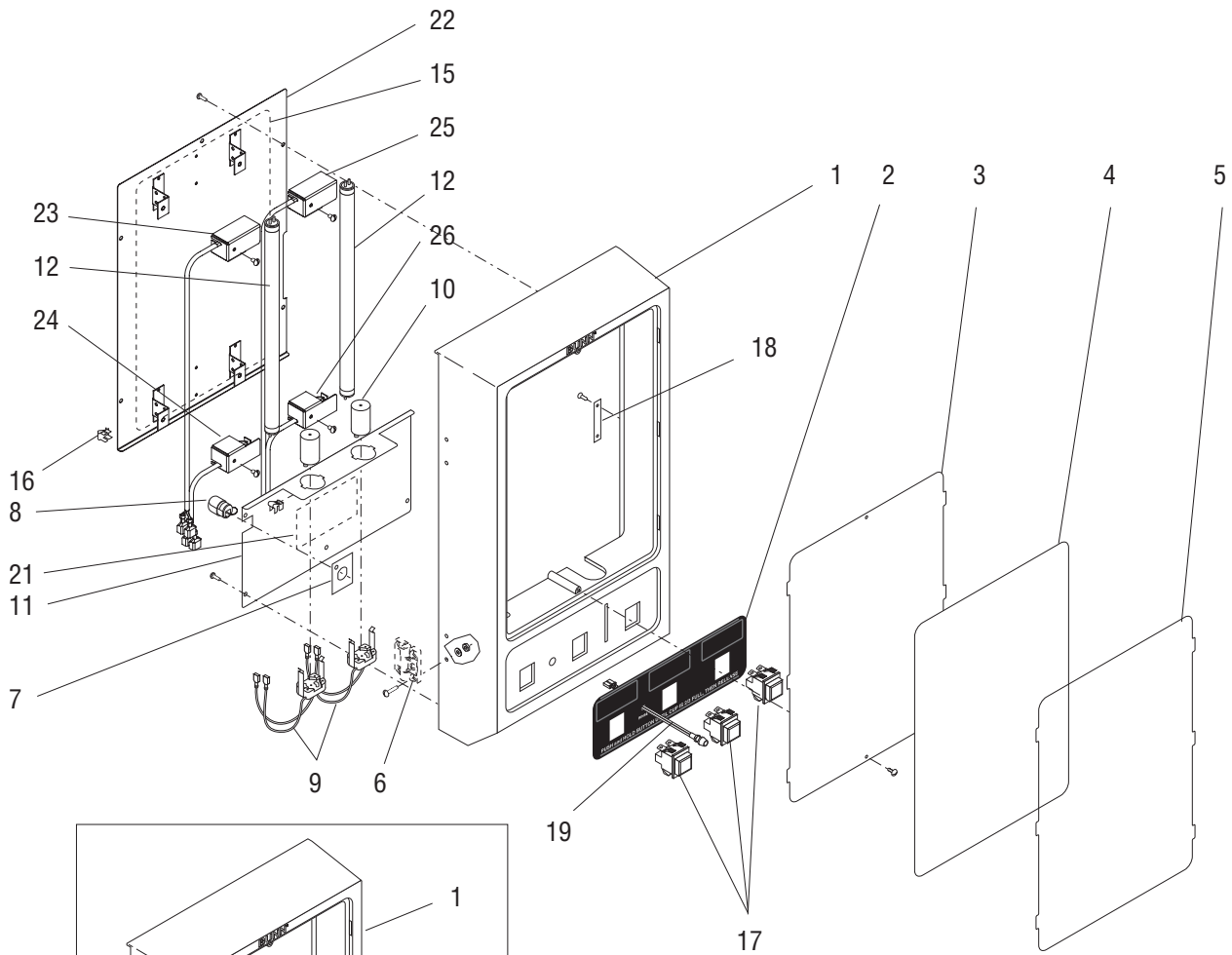

## DOOR, LAMP, DISPENSE SWITCHES AND PANELS

ITEM	PART NO.	QTY.	DESCRIPTION
22	28332.0004*	1	Panel, Upper w/ 2 lights (Late Models)
	28332.0003*	1	Panel, Upper w/ 1 light (Late Models)
	01383.0001	5	Screw, Truss Head #6 - 32 x .25"
23	27543.1005	1	Lampholder Assy, Upper Left (Late Models w/ 1 or 2 lights)
	01308.0000	1	Screw, Truss Head #6-32 x .25"
24	27543.1006	1	Lampholder Assy, Lower Left (Late Models w/ 1 or 2 lights)
	01308.0000	1	Screw, Truss Head #6-32 x .25"
25	27543.1001	1	Lampholder Assy, Upper Right (Late Models w/ 2 lights only)
	01308.0000	1	Screw, Truss Head #6-32 x .25"
26	27543.1002	1	Lampholder Assy, Lower Right (Late Models w/ 2 lights only)
	01308.0000	1	Screw, Truss Head #6-32 x .25"

NOTE: The following items are not illustrated

27	28549.0000	1	Wiring Harness, Door Interconnect 120V (Includes item 7 & 1 of item 8) (Dispensers w/out digital touch control)
	29066.0000	1	Wiring Harness, Door Interconnect 120V (Includes item 7 & 1 of item 8) (Dispensers w/digital touch control)
	29066.0001	1	Wiring Harness, Door Interconnect 120V (Dispenser /Hot water valve)
28	28336.0000	2	Wiring Harness, Door 120V (120V & 230V "A" Model dispensers)
29	26537.0000	1	Decal, Flavors (Almond Amaretto, Cappuccino, French Vanilla, Hazelnut, Chocolate Raspberry, Cappuccino Supreme, Hot Chocolate and Raspberry Mocha)
	26537.0001	1	Decal, Flavors (Swiss Mocha, Mocha, Raspberry Vanilla, Irish Creme, Coffee, Original, Chocolate French Vanilla and Butter Pecan)
	26537.0003	1	Decal, Flavors (White Chocolate, Cinnamon Vanilla Nut, Decaf, Regular, Apple Cider, Fat Free French Vanilla and Cinnamon Vanilla)
	28833.0000	1	Decal, Soup Flavors (Cream of Chicken, Mushroom, Tomato, Broccoli, Potato and Cheddar Cheese)
	28833.0001	1	Decal, Soup Flavors (Chicken Consomme, French Onion, Chicken Noodle, Beef Noodle, Seafood Bisque and Clam Chowder)
30	21004.0338*	1	Lead 18AWG, GRN, 6.0" (Door Grounding)

\* Indicates the part number listed is for reference only. See DESCRIPTION for possible service replacement.

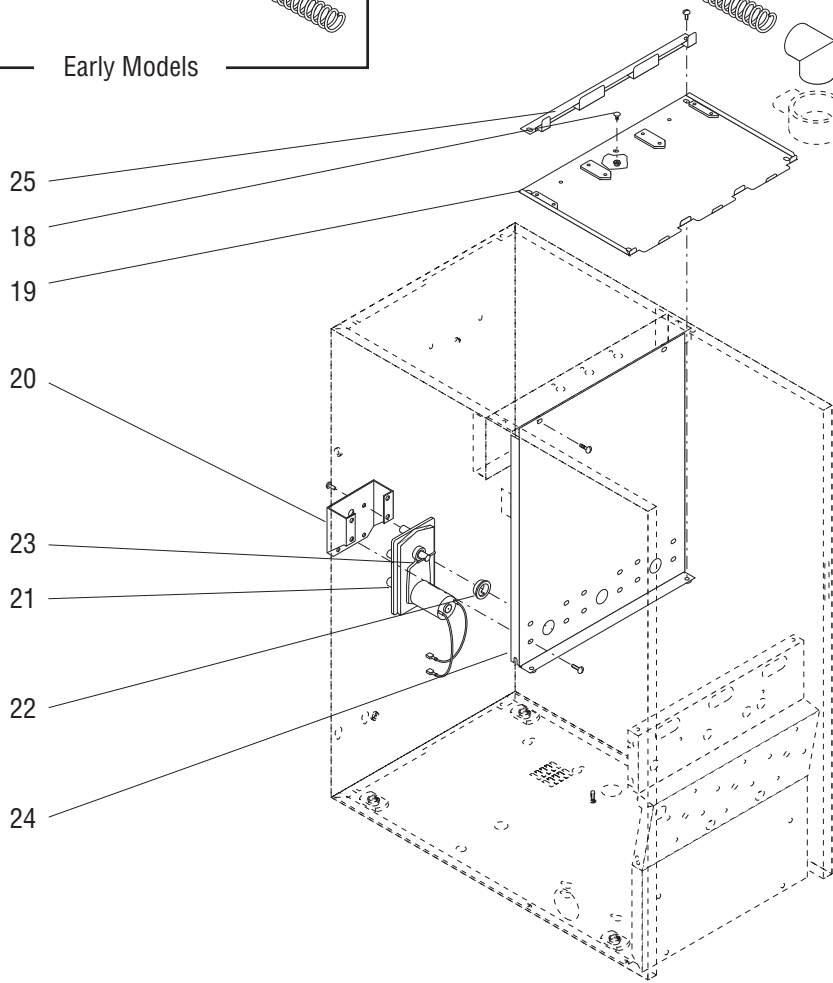
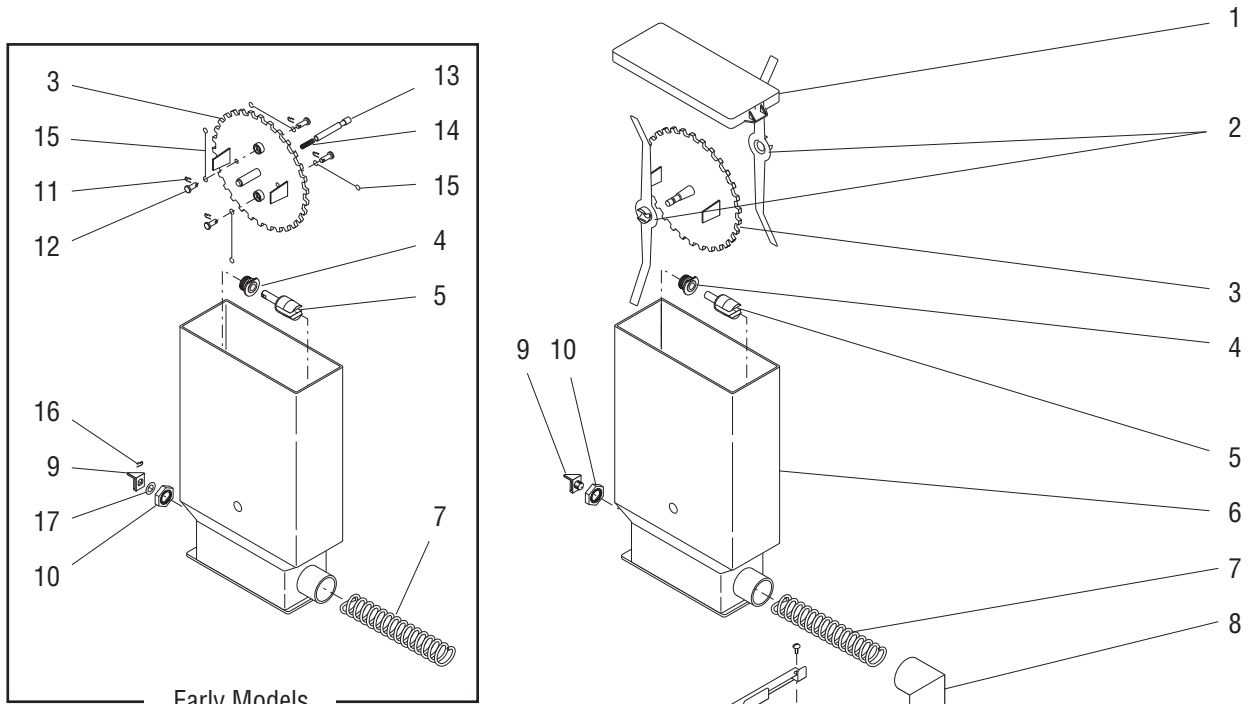

## AUGER DRIVE AND HOPPER ASSEMBLY

ITEM	PART NO.	QTY.	DESCRIPTION
-	28424.1003	3	Hopper Assy (22 Tooth Agitator Disk) (Includes items 1 thru 10)
-	28424.1004	3	Hopper Assy (30 Tooth Agitator Disk) (Includes items 1 thru 10)
1	28061.0000	1	Lid, Hopper
2	32337.0000	2	Mixing Blade (Late models)
3	26435.0000	1	Disk, Agitator (22 Tooth)
	26435.0001	1	Disk, Agitator (30 Tooth)
	32386.0000	1	Disk, Agitator (22 Tooth)
	32386.0001	1	Disk, Agitator (30 Tooth)
4	28067.0000	1	Bushing, Auger Drive Shaft
5	-----	1	Shaft, Auger Drive (Early models order item 27)
	26940.0002	1	Shaft, Auger Drive (Late models)
6	28425.0000	1	Hopper
7	26112.0001	1	Auger, Wire (use w/22-tooth Disk)
	21355.0001	1	Auger, Wire (use w/30-tooth Disk)
8	25903.0000	1	Elbow, Ejector
9	-----	1	Bracket, Auger Drive (Early models order item 27)
	32383.0000	1	Bracket, Auger Drive (Late models)
10	25743.0000	1	Locknut
11	21358.0000	4	Clip, Retainer
12	21357.0000	4	Shaft, Wiper
13	26436.0000	1	Rod, Agitator Support
14	26449.0000	1	Spring
15	26441.0000	4	Wire, Agitator
16	21358.0000	1	Clip, Retainer
17	21365.0000	1	Washer, .31" I.D. x .56" O.D.
18	20960.0000	3	Screw, Shoulder #6-32 x .375"
	00991.0002	3	Nut, Elastic Lock #6-32
19	29933.1000	1	Panel, Hopper Support
	01311.0000	4	Screw, Truss Head #8-32 x .25"
20	25794.0001	3	Bracket, Motor Mounting
	01311.0001	12	Screw, Truss Head #8-32 x .25" Locking
21	29642.1001	3	Gearmotor W/Pin, Auger (Includes item 20 & 23)
	01311.0000	12	Screw, Truss Head #8-32 x .25"
	01511.0000	3	Lock Washer, External Tooth #8
22	26401.0000	3	Dust Seal, Hopper Motor
23	26247.0000	3	Pin, Spring .094" Dia. x 1.0"
	26247.1000	-	Kit, Spring Pin (Includes 6 Pins)
24	28286.0000	1	Panel, Hopper Motor Mounting
	01311.0001	2	Screw, Truss Head - Locking #8-32 x .25"
25	29713.0000	1	Bracket, Hopper Locator
26	11685.0000	1	Brush, Hopper Cleaning (Not Illustrated)
27	32394.0000	-	Kit, Auger Drive Shaft (Converts early model Drive Shaft to late model Drive Shaft)

Early models  
Late models

Early models

\* Indicates the part number listed is for reference only. See DESCRIPTION for possible service replacement.

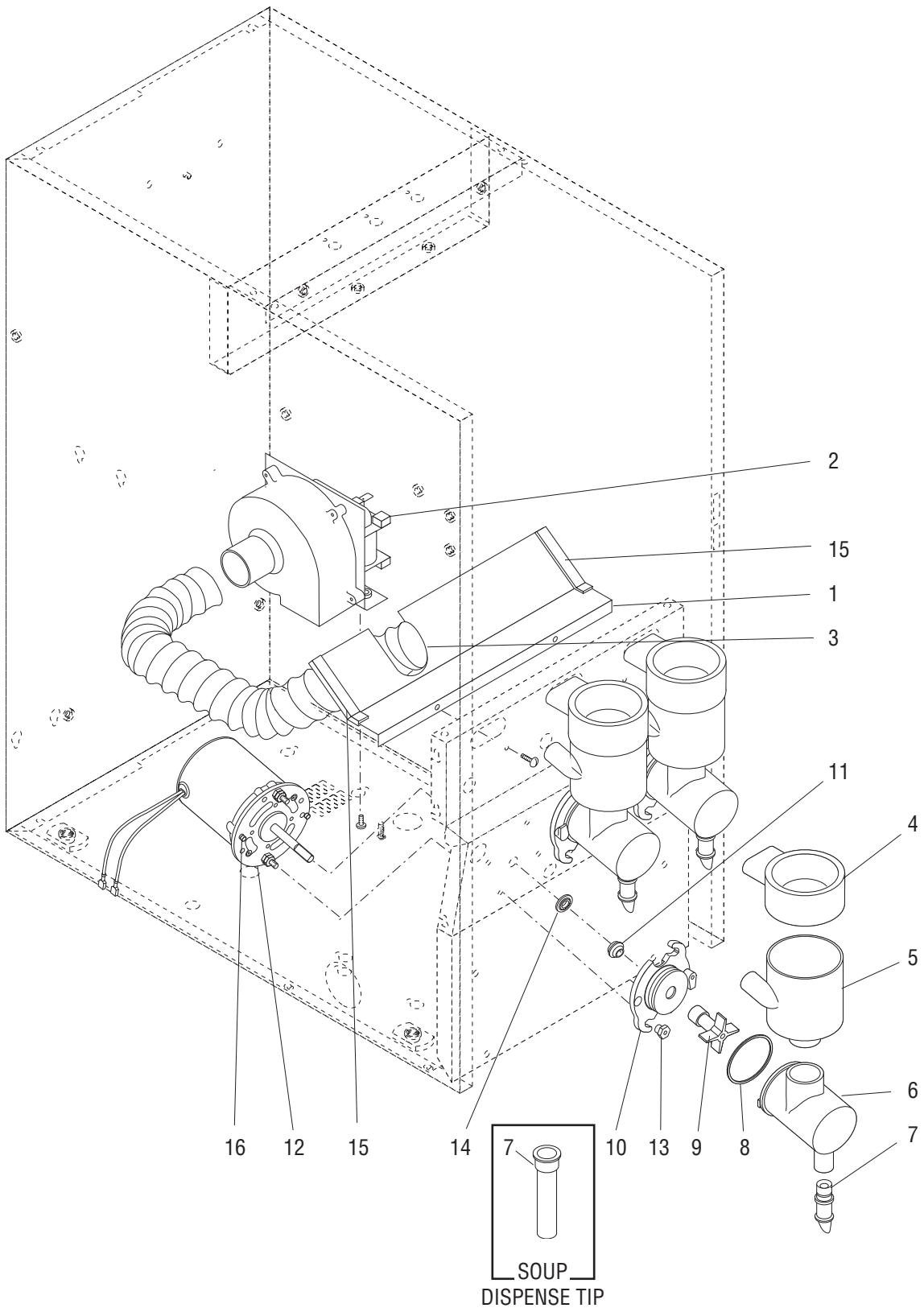

## MIXING/WHIPPER CHAMBERS AND DRIVE MOTOR

ITEM	PART NO.	QTY.	DESCRIPTION
1	28208.1000	1	Baffle Assembly, Fan (Includes item 15)
	02336.0000	2	Screw, Truss Head #4-40 x .25"
2	28295.0000	1	Fan & Bracket Assembly 120V
	28295.0001	1	Fan & Bracket Assembly 230V (240V & 230V "A" Model dispensers)
	01311.0001	2	Screw, Truss Head - Locking #8-32 x .25"
3	28297.0000	1	Hose, Vacuum
4	25732.0000	3	Steam Collector
5	25733.0000	3	Mixing Chamber
6	25734.1000	3	Whipper Chamber
	25734.7002	3	Whipper Chamber (FMD-3C)
7	25736.0000	3	Dispense Tip - Beverages
	28864.0000	3	Dispense Tip - Soup
8	24733.0010	3	O-Ring
9	25902.0000	3	Frother
10	28866.0000	3	Receptacle, Whipper Chamber
11	26356.0000	3	Seal, Shaft
	26356.1000	-	Kit, Shaft Seal (Includes 6 Seals)
12	28428.1000	3	Motor, Whipper 120V (Includes item 16)
	28428.0006*	3	Motor, Whipper 240V (240V & 230V "A" Model dispensers) (Includes item 16)
13	28865.0000	6	Nut, Whipper Motor/Receptacle Mounting
14	28867.0000	3	Slinger
15	02434.0009*	2	Gasket, Silicone 2.25" LG (Order item 17)
16	32306.0000	6	Spacer
17	02434.1000	-	Gasket, Silicone 18" LG
18	32906.0000	-	Kit, Preventive Maintenance (Includes items 4 thru 11 and 25903.0000 Elbow)

\* Indicates the part number listed is for reference only. See DESCRIPTION for possible service replacement.

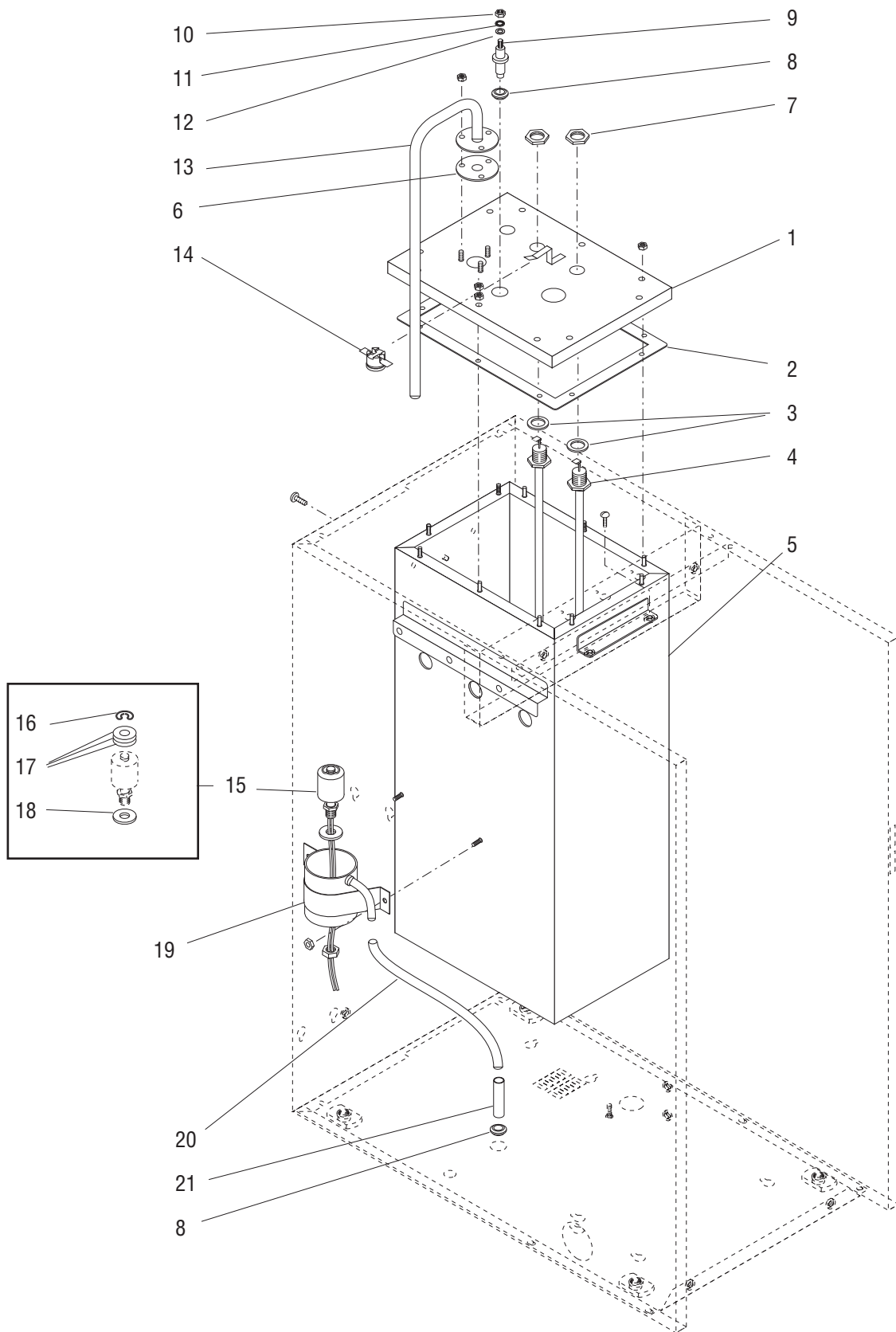



## TANK, HEATER AND OVERFLOW PROTECTION

ITEM	PART NO.	QTY.	DESCRIPTION
1	28281.0000	1	Lid, Tank
	00908.0000	11	Nut, Hex #8-32
2	22978.0000	1	Gasket, Tank Lid
3	00943.0000	2	Gasket, Tank Heater
4	20201.4151	1	Tank Heater Kit, 1700W 120V (Includes item 3)
	20201.0750	1	Tank Heater Kit, 3500W 240V (240V & 230V "A" Model dispensers) (Includes item 3)
5	37978.1000	1	Tank
	37978.1001	1	Tank (Used with Hot Water Valve dispensers)
	02308.0000	2	Screw, Pan Head - Serrated #8-32 x .375"
	01311.0003	2	Screw, Truss Head - BLK Locking #8-32 x .250"
	01311.0001	2	Screw, Truss Head - SST Locking #8-32 x .250"
6	05515.0000	1	Gasket, Overflow Tube
7	00942.0000	2	Nut, Hex .50"-20
8	02536.0000	2	Grommet, .375" I.D.
9	07412.1002	1	Probe Kit (Includes items 10, 11 & 12)
10	00908.0000	1	Nut, Hex #8-32
11	20203.0100	1	Lockwasher, Internal Tooth #8
12	01501.0000	1	Washer, Flat .16" I.D. x .375" O.D.
13	28292.0000	1	Tube Assy, Overflow
	00908.0000	3	Nut, Hex #8-32
14	29329.1000	1	Thermostat, Limit
15	03803.0000	1	Switch Assy, Liquid Level (Includes items 16, 17 & 18)
	00946.0000	1	Nut, Hex .125" FPT
16	03807.0000	1	Clip, Spring
17	-----	3	Washer, Adjusting (DO NOT USE IN THIS APPLICATION)
18	03633.0000	2	Gasket, Float Switch (Only 1 used in this application)
19	12552.0000	1	Overflow Cup
	00908.0000	2	Nut, Hex #8 - 32
20	28526.0000*	1	Tube, Silicone .312" I.D. x .562 x 11.5" (Order item 23)
21	21801.0015	1	Tube, .375" O.D. x 1.50"
22	01570.0000	2	Wire Nut, 2 - 24 AWG
23	28526.1000	-	Tube, Silicone .312" I.D. x .562" O.D. x 12"
	28526.1001	-	Tube, Silicone .312" I.D. x .562" O.D. x 36"
	28526.1002	-	Tube, Silicone .312" I.D. x .562" O.D. x 60"
	28526.1003	-	Tube, Silicone .312" I.D. x .562" O.D. x 120"

} Not Illustrated

\* Indicates the part number listed is for reference only. See DESCRIPTION for possible service replacement.

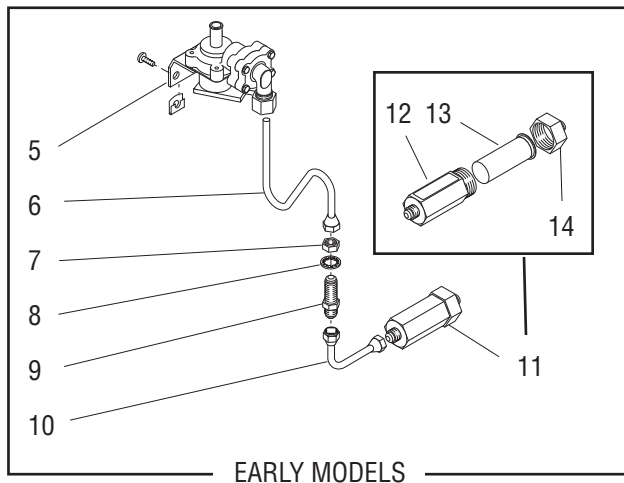
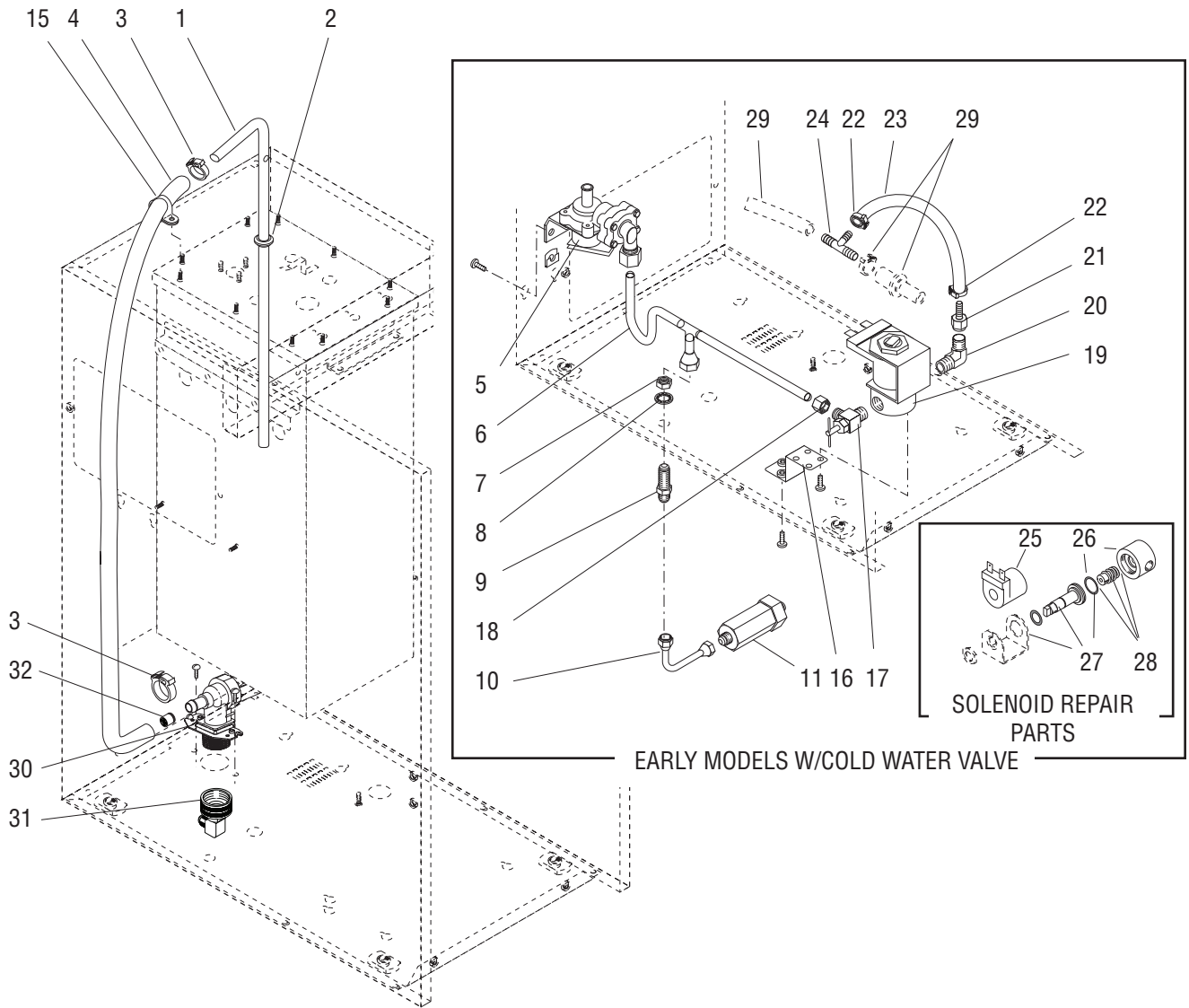

## STRAINER, SOLENOID, FILL VALVE AND LINES

ITEM	PART NO.	QTY.	DESCRIPTION
1	28298.0000	1	Tube, Tank Fill
2	02536.0000	1	Grommet, .375" I.D.
3	12422.0001	2	Clamp, Hose .59"/.66" I.D. (One less used on Late Models)
	12422.0005	1	Clamp, Hose .62"/.71" I.D. (Late Models)
4	28526.0004*	1	Tube, Silicone .312" I.D. x .562" O.D. x 22.75" (Order item 33)(Early Models)
	20976.0085*	1	Tube, Silicone .312" I.D. x .562" O.D. x 22.75" (Order item 37)(Late Models)
5	26135.1001	1	Valve Assy, Solenoid 120V (Serviced only as an assembly) (See Item 34)
	26135.0002	1	Valve Assy, Solenoid 240V (240V & 230V "A" Model dispensers) (Serviced only as an assembly) (See item 31)
	02322.0002	2	Screw, Truss Head - BLK #8-32 x .375"
	01315.0000	2	Screw, Truss Head - SST #8-32 x .375"
	00938.0000	2	Fastener, U-Type #8-32
6	26661.0000	1	Tube Assy, Water Inlet (Models w/out cold water valve)
	28330.1000	1	Tube Assy, Water Inlet (Models w/cold water valve)
7	00463.0001	1	Nut, Hex .438"-20
8	01532.0000	1	Lockwasher, Internal Tooth .438"
9	00459.0000	1	Fitting, Bulkhead
10	21814.0016	1	Tube Assy
11	23820.1000	1	Water Strainer Assy (Includes item 12 thru 14)
12	-----	1	Body (Not available order item 11)
13	23721.0000	1	Screen
14	22249.0000	1	End Cap
15	00620.0000	1	Clamp, Hose
16	28275.0000	1	Bracket, Solenoid Mounting
	01311.0004	2	Screw, Truss Head - Locking BLK #8-32 x .25"
17	00408.0001	1	Valve, Needle .25" Tube (Includes item 18)
18	00443.0000	1	Nut/Sleeve Assy, Compression
19	01085.0002	1	Solenoid Valve Assy, 120V
	01326.0000	2	Screw, Truss Head #10-32 x .25"
20	00400.0001	1	Elbow, Male .25" Male Flare x .125" MPT
21	004251000	1	Fitting, .25" Barb x .25" Flare Nut
22	12422.0000	2	Clamp, Hose .47"/.54" I.D.
23	11707.0026*	1	Tube, Silicone .25" I.D. x 9.5" LG (Order item 35)
24	26442.0000	1	Tee, Barb .375" x .375" x .25"
25	28480.0000	1	Coil, Solenoid Valve 120V
26	28479.0000	1	Base Kit, Solenoid Valve (Includes O-Ring)
27	28481.0000	1	Guide Kit, (Includes Washer & O-Ring)
28	01111.0002	1	Solenoid Valve Repair Kit (Includes Spring, Plunger and O-Ring)
29	-----	-	Tube & Clamp (See DISPENSE VALVES AND LINES)

\* Indicates the part number listed is for reference only. See DESCRIPTION for possible service replacement.

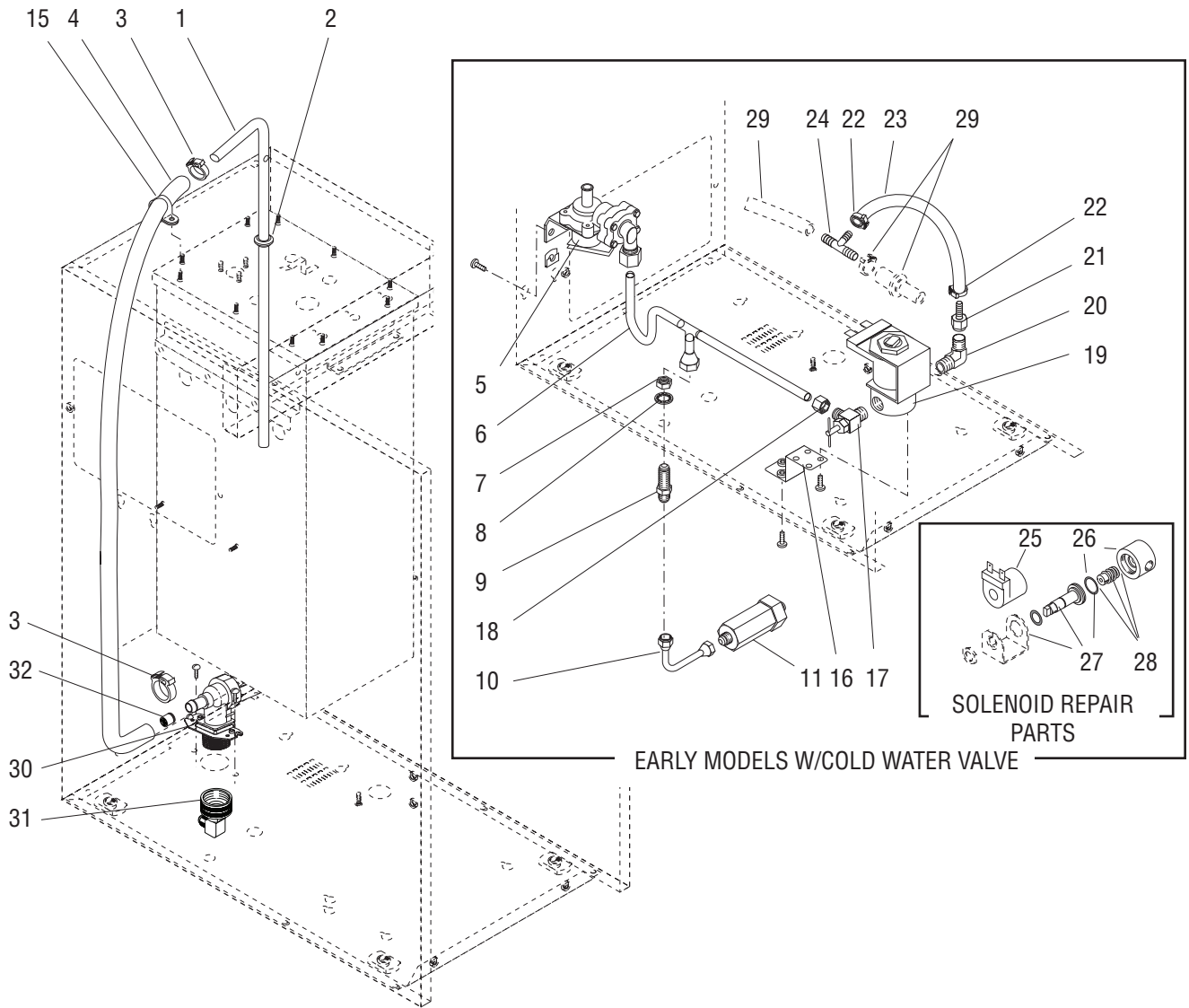

EARLY MODELS W/COLD WATER VALVE

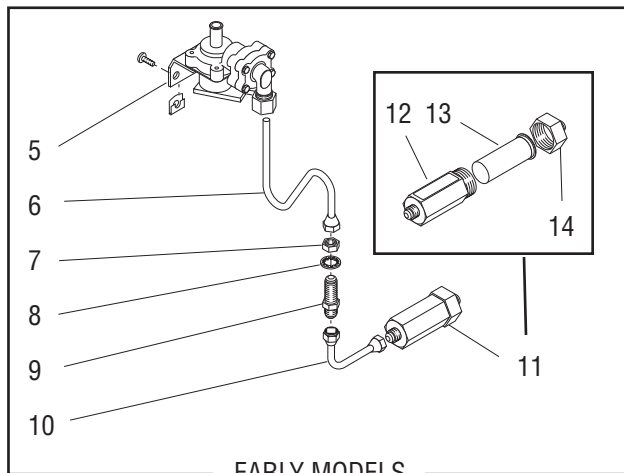

EARLY MODELS

## STRAINER, SOLENOID, FILL VALVE AND LINES

ITEM	PART NO.	QTY.	DESCRIPTION
30	36233.1000	1	Valve, Inlet Solenoid 120V (Late Models)(See item 36)
	32283.0000	2	Screw, Pan Head M4 x 6mm
31	37297.0006	1	Elbow (Late Models)
32	36378.0001	1	Check Valve 2.5psi (Late Models)
33	28526.1001	-	Tube, Silicone .312" I.D. x .562" O.D. x 36"
	28526.1002	-	Tube, Silicone .312" I.D. x .562" O.D. x 60"
	28526.1003	-	Tube, Silicone .312" I.D. x .562" O.D. x 120"
34	26131.0000	-	Kit, Nut/O-ring (Includes Nut, Spacer, Grab Ring, Washer & 2 O-Rings)
35	11707.1000	-	Tube, Silicone .25" I.D. x .50" O.D. x 12"
	11707.1001	-	Tube, Silicone .25" I.D. x .50" O.D. x 36"
	11707.1002	-	Tube, Silicone .25" I.D. x .50" O.D. x 120"
36	43644.0000	-	Kit, Valve Rebuild
37	20976.1000	-	Tube, Silicone .38" ID x 12.0" (Use as required)
	20976.1001	-	Tube, Silicone .38" ID x 36.0" (Use as required)
	20976.1002	-	Tube, Silicone .38" ID x 120.0" (Use as required)

\* Indicates the part number listed is for reference only. See DESCRIPTION for possible service replacement.

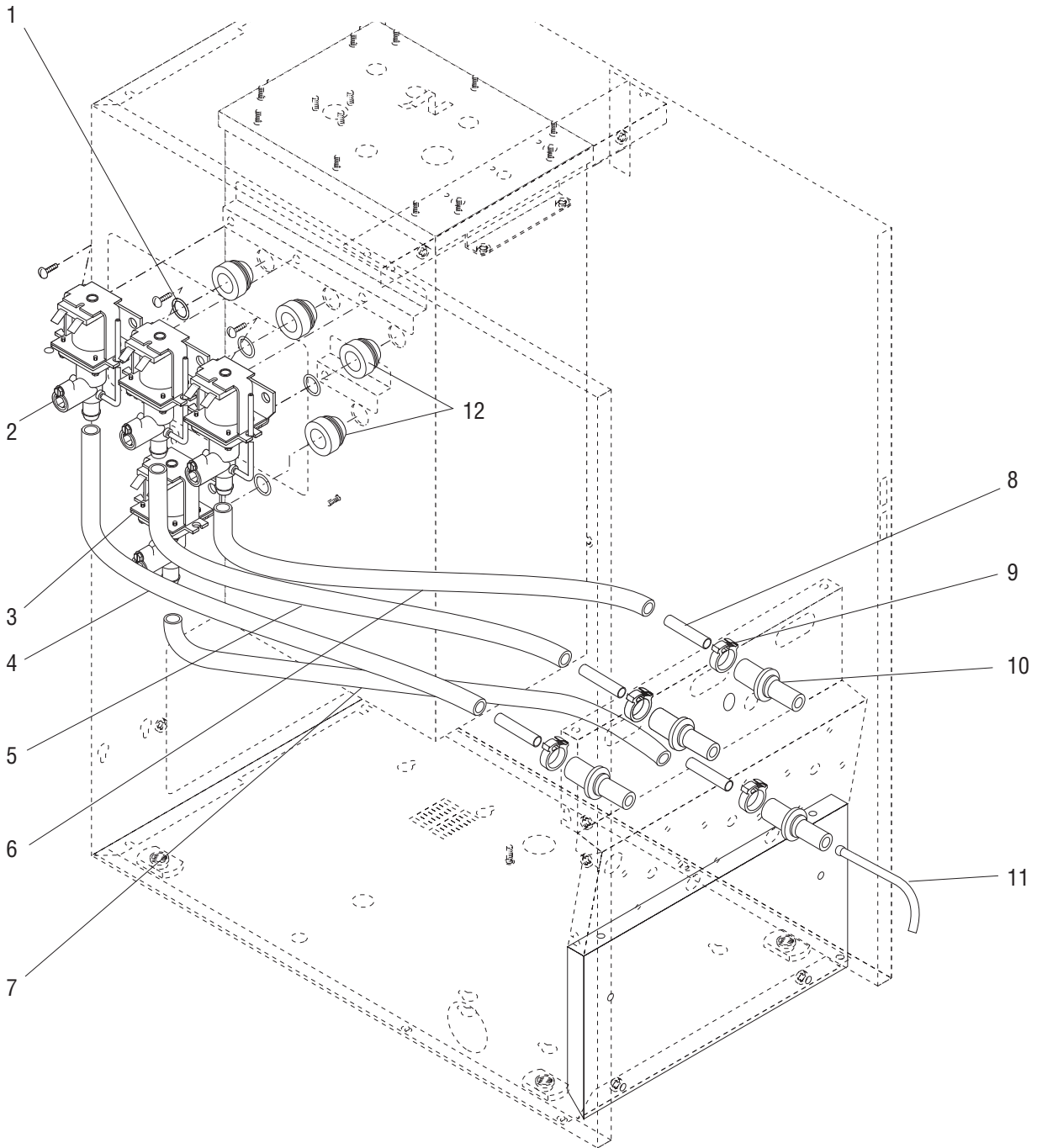

## DISPENSE VALVES AND LINES

ITEM	PART NO.	QTY.	DESCRIPTION
1	24733.0011	3	O-Ring (One additional used on Models with Hot water valve)
2	39285.1001	3	Valve, Liquid Dispense 120V (Includes item 1)
	39285.1002	3	Valve, Liquid Dispense 240V (Includes item 1) (240V & 230V "A" Model dispensers)
	01326.0000	3	Screw, Truss Head #10-32 x .250"
3	39316.1001	1	Valve, Liquid dispense (Models w/hot water valve)
	39316.1002	1	Valve, Liquid dispense (Models w/hot water valve)(230V "A" Model dispensers only)
	01326.0000	1	Screw, Truss Head #10-32 x .250"
4	28526.0001*	1	Tube, Silicone .312" I.D. x .562" O.D. x 18.5" (Order item 13) (Models w/out cold water valve)
	28526.0005*	1	Tube, Silicone .312" I.D. x .562" O.D. x 17.90" (Order item 13) (Models w/cold water valve)
5	28526.0006*	1	Tube, Silicone .312" I.D. x .562" O.D. x 13.5" (Order item 13)
6	28526.0003*	1	Tube, Silicone .312" I.D. x .562" O.D. x 15.75" (Order item 13)
7	28526.0002*	1	Tube, Silicone .312" I.D. x .562" O.D. x 16.0" (Order item 13) (used on Models w/hot water valve)
8	21801.0015	3	Tube, .375" O.D. x 1.50" (One less used on Models w/cold water valve) (One additional used on Models w/hot water valve)
9	12422.0001	3	Clamp, Hose .59"/.66" I.D (One additional used on Models w/cold water valve and hot water valve)
10	25803.0000	3	Water Inlet, Mixing Chamber (One additional used on Models w/hot water valve)
11	32341.0000	1	Tube, Dispense Hot Water (Models w/hot water valve)
12	37970.0000	3	Grommet (One additional used on Models with Hot water valve)
13	28526.1001	-	Tube, Silicone .312" I.D. x .438" O.D. x 36"
	28526.1002	-	Tube, Silicone .312" I.D. x .438" O.D. x 60"
	28526.1003	-	Tube, Silicone .312" I.D. x .438" O.D. x 120"
14	45965.1000	-	Repair Kit, Dispense Valve

} Not  
Illustrated

\* Indicates the part number listed is for reference only. See DESCRIPTION for possible service replacement.

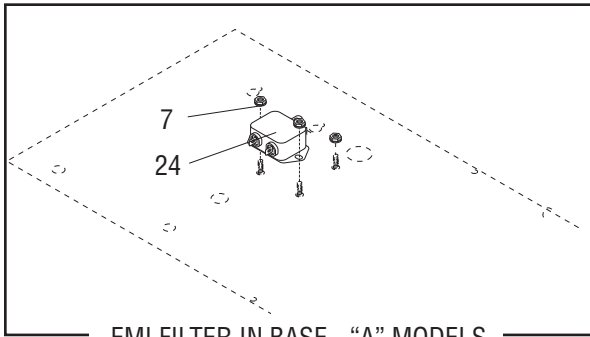

EMI FILTER IN BASE - "A" MODELS

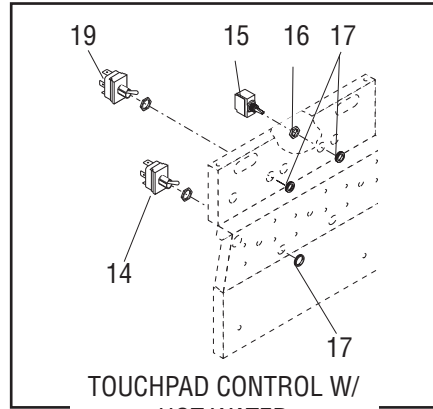

TOUCHPAD CONTROL W/  
HOT WATER

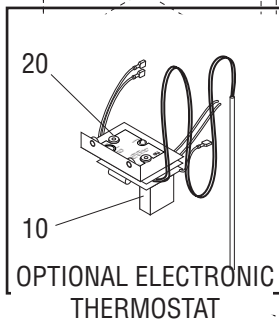
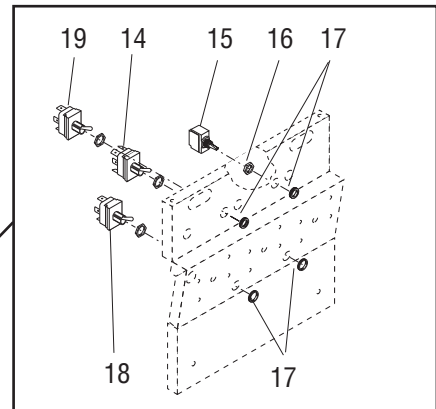
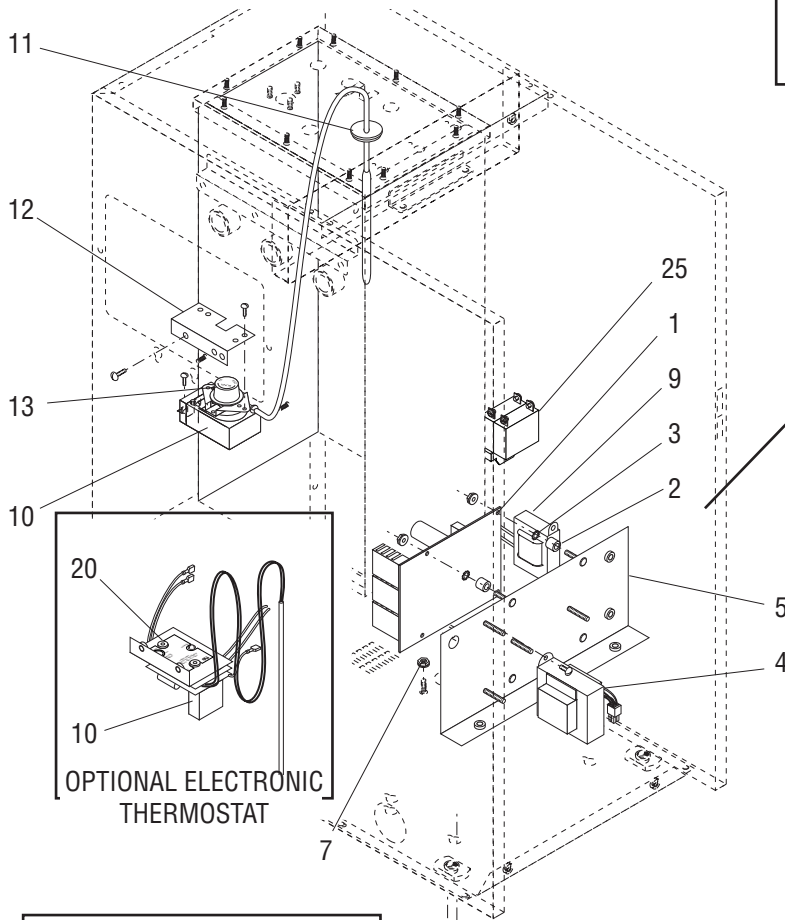

OPTIONAL ELECTRONIC  
THERMOSTAT

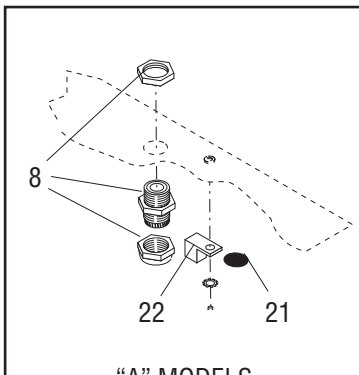

"A" MODELS

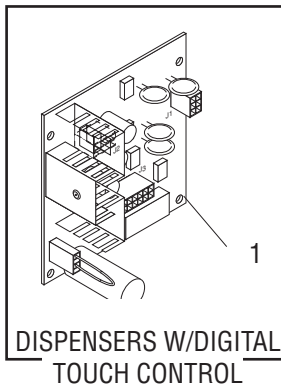

DISPENSERS W/DIGITAL  
TOUCH CONTROL

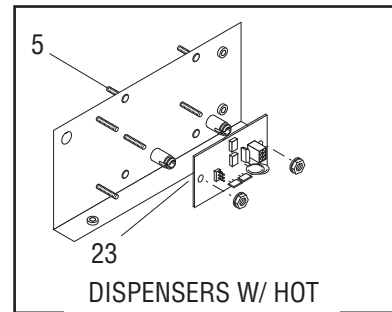

DISPENSERS W/ HOT  
WATER VALVE



## ELECTRICAL CONTROLS

ITEM	PART NO.	QTY.	DESCRIPTION
1	42996.1000	1	Control Board, 120V & 240V (Dispensers w/o digital touch control)
	39332.1000	1	Control Board (120V & 230V "A" Model dispensers) (Includes item 29) (Dispensers w/digital touch control)
	00973.0000	4	Nut, Keps #6-32
2	00450.0000	4	Spacer, .219" I.D. x .34" LG - Brass
3	01510.0000	4	Lockwasher, External Tooth #6
4	28860.0000	1	Transformer Assy, 120V to 24V
	28860.0001	1	Transformer Assy, 240V to 24V (240V & 230V "A" Model dispensers)
	00973.0000	2	Nut, Keps #6-32
5	28869.0002	1	Bracket, Component Mounting
	01311.0001	2	Screw, Truss Head - Locking #8-32 x .25"
6	00715.0000	1	Adapter Washer, Strain Relief (Not used on 120V, 120/208V or 120/240V dispensers)
7	00973.0000	2	Nut, Keps #6-32
8	01686.0000	1	Bushing, Strain Relief (120V & 230V "A" Model dispensers)
	28683.0000	1	Bushing, Strain Relief (120/208V & 120/240V dispensers)
9	28327.0000	1	Ballast, 120V-60HZ W/Terminals
	39642.0000	1	Ballast, 240V-50HZ W/Terminals (240 & 230V "A" Model dispensers)
	01311.0001	2	Screw, Truss Head - Locking #8-32 x .25"
10	-----	1	Thermostat Assembly 120V - Mechanical (Not Available. Order Item 33)
	02328.0003	2	Screw, Pan Head #6-32 x .25" (Mounting)
	20762.0000	2	Screw, Binding Head #8-32 x .25" (Terminal)
	40791.1006	1	Thermostat Assembly 120V - Electronic (Includes item 20)
	01311.0000	2	Screw, Truss Head - SST #8-32 x .25"
	01311.0003	2	Screw, Truss Head - BLK #8-32 x .25"
	28367.1000	1	Thermostat Assembly - Electronic (Includes item 20) (230V "A" Model dispensers Only)
11	07073.1000	1	Grommet - Mechanical Thermostats
	12570.0000	1	Grommet - Electronic Thermostats
12	28224.0000	1	Bracket, Thermostat Mounting - Mechanical Thermostat
	01311.0003	2	Screw, Truss Head - BLK #8-32 x .25"
	01311.0000	2	Screw, Truss Head - SST #8-32 x .25"
13	00720.0000	1	Knob, Thermostat Adjustment - Mechanical Thermostat
14	28857.1000	1	Switch, Toggle Run/Rinse/Program (Includes item 16, also order item 17) (Dispensers w/out digital touch control)
	02686.0000	1	Switch, Toggle ON/OFF (Includes item 16, also order item 17) (Dispensers w/digital touch control)
15	23522.1000	1	Switch, Toggle ON/OFF-Tank Heater (Includes item 16, also order item 17)
16	23696.0000	4	Nut, Hex .469" - 32
17	23697.0000	4	Nut, Plastic Face .469" - 32
18	28856.1000	1	Switch, Toggle - Increase/Decrease (Includes item 16, also order item 17) (Dispensers w/out digital touch control)

(Continued)

\* Indicates the part number listed is for reference only. See DESCRIPTION for possible service replacement.

(Continued)

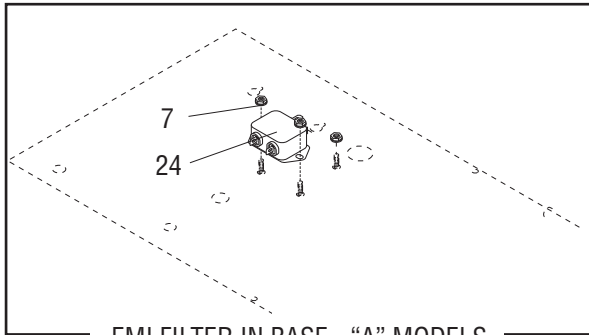

EMI FILTER IN BASE - "A" MODELS

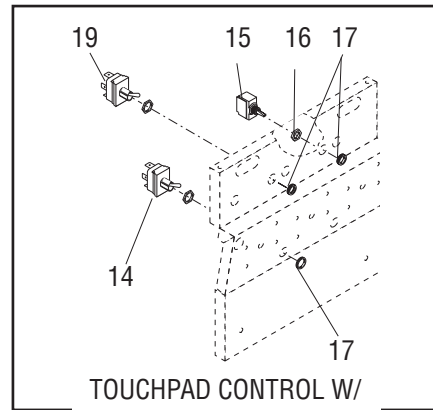

TOUCHPAD CONTROL W/  
HOT WATER

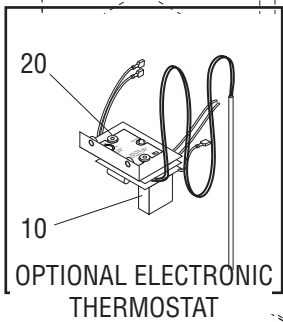
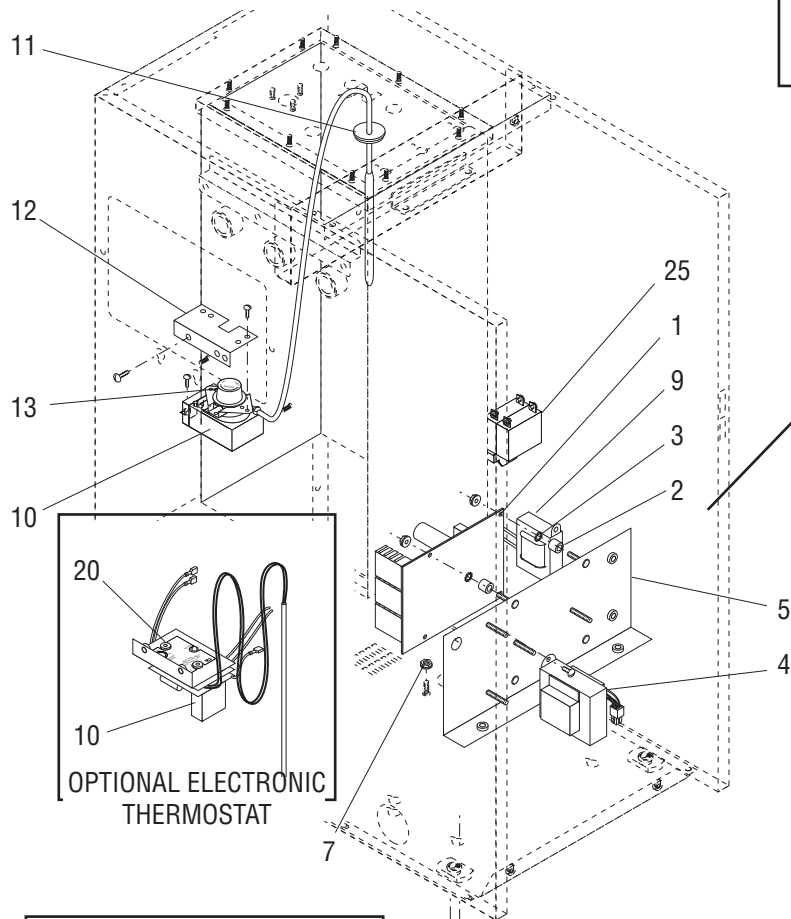

OPTIONAL ELECTRONIC  
THERMOSTAT

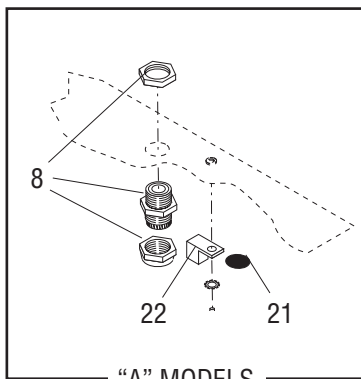
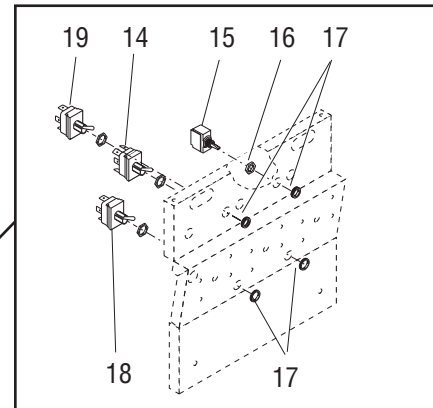

"A" MODELS

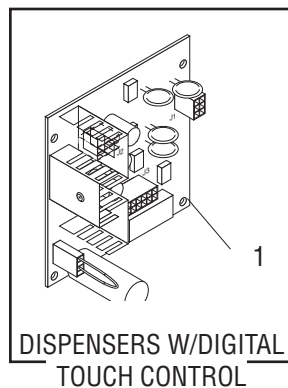

DISPENSERS W/DIGITAL  
TOUCH CONTROL

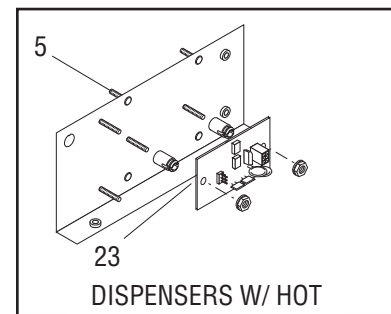

DISPENSERS W/ HOT  
WATER VALVE

## ELECTRICAL CONTROLS

ITEM	PART NO.	QTY.	DESCRIPTION
19	05761.0000	1	Switch, Toggle ON/ON - Cold Water Valve (Includes item 16, also order item 17)
20	26536.0003*	1	Decal - Thermostat Adjustments - Electronic Thermostat
21	00824.0002	1	Decal, Ground
22	27705.0000	1	Terminal Lug, Ground
	01375.0000	1	Screw, Pan Head Brass #10-32 x .50"
	01512.0000	1	Lockwasher, Internal Tooth #10
23	38737.1000	1	Circuit Board, Auxiliary Control (used only on dispensers w/HWV)
	29081.0002	2	Spacer
	00973.0000	2	Nut, Keps #6-32
24	36801.0001	1	EMI Filter, 15Amp (230V "A" Model dispensers only)
	02308.0000	2	Screw, Pan Head #8-32 x .375"
25	38894.0001	1	Switch, Master ON/OFF
	01308.0002	2	Screw, Truss Hd., Locking #6-32 x .25" (mounting)
	01327.0000	4	Screw, Pan Hd. #10-32 x .38"  terminals
	01512.0000	4	Lockwasher #10

The following items are not illustrated

26	20630.0008	1	Cord Assembly, Power 120V
	28680.0001	1	Cord Assembly, Power 120/208V & 120/240V (w/o Master ON/OFF Sw.)
	28680.0004	1	Cord Assembly, Power 120/208V & 120/240V (w/ Master ON/OFF Sw.)
	33529.0006	1	Cord Assembly, Power 230V
	35155.0000	1	Cord Assembly, Power 240V
27	28548.0000	1	Wiring Harness, Control - 120V & 240V (Dispensers with mechanical thermostat & w/out digital touch control)
	29067.0000	1	Wiring Harness, Control - 120V (Dispensers with mechanical thermostat & w/digital touch control)
	29067.0001	1	Wiring Harness, Control - 120/208V & 120/240V (Dispensers with Hot water valve)
	29067.0007	1	Wiring Harness, Control - 230V (230V "A" Model dispensers) (Dispensers with hot water valve & w/digital touch control)
	28548.0001	1	Wiring Harness, Control - 120/208V & 120/240V (Dispensers w/out digital touch control)
	28548.0002	1	Wiring Harness, Control - 120V & 240V (Dispensers with electronic thermostats and dispensers w/out digital touch control)
28	38920.0008	1	Wiring Harness, Master ON/OFF Sw.
29	27605.0000	1	Wiring Harness, Cold Water Valve
30	-----	1	Wiring Harness, Door (See Door, Lamps and Panels)
31	28862.0000	1	Lead Assembly, Jumper (Dispensers w/out cold water valve)
32	02244.0000	1	Jumper, Two Position (Dispensers w/out digital touch control)
	29199.0000	1	Jumper Assembly, Rinse Timer (Dispensers w/digital touch control)
33	40791.1006	-	Thermostat Kit (Includes items 10, 12 & 13)

\* Indicates the part number listed is for reference only. See DESCRIPTION for possible service replacement.

NUMERICAL INDEX

PART NO.	PAGE NO.	PART NO.	PAGE NO.	PART NO.	PAGE NO.	PART NO.	PAGE NO.
00400.0001	19	02536.0000	17,19	25736.0000	15	28261.0001	9
00408.0001	19	02686.0000	25	25743.0000	13	28267.0000	5
00425.1000	19	03633.0000	17	25794.0001	13	28268.0000	5
00443.0001	19	03803.0000	17	25803.0000	23	28270.0000	5
00450.0000	25	03807.0000	17	25902.0000	15	28270.0001	5
00459.0000	19	03996.0000	7	25903.0000	13	28275.0000	19
00463.0000	19	05515.0000	17	26112.0001	13	28281.0000	17
00619.0010	5	05761.0000	27	26131.0000	21	28286.0000	13
00619.0011	7	07073.1000	25	26135.1001	19	28292.0000	17
00620.0000	19	07412.1002	17	26135.0002	19	28295.0000	15
00656.0001	7	11685.0000	13	26239.0000	9	28295.0001	15
00713.0000	25	11707.0026	19	26247.0000	13	28296.1000	9
00715.0000	25	11707.1000	21	26247.1000	13	28297.0000	15
00720.0000	25	11707.1001	21	26356.0000	15	28298.0000	19
00824.0002	27	11707.1002	21	26356.1000	15	28301.0003	9
00831.0000	7	12422.0000	19	26401.0000	13	28322.0000	9
00908.0000	17	12422.0001	19,23	26435.0000	13	28325.0000	9
00938.0000	19	12422.0005	19	26435.0001	13	28327.0000	25
00942.0000	17	12517.0001	9	26436.0000	13	28330.1000	19
00943.0000	17	12552.0000	17	26441.0000	13	28332.0003	11
00946.0000	17	12570.0000	25	26442.0000	19	28332.0004	11
00973.0000	25,27	13255.0003	7	26444.0000	9	28332.1000	9
00991.0000	5,9	20201.0750	17	26449.0000	13	28335.0000	9
00991.0002	13	20201.4151	17	26504.0000	5	28336.0000	11
01085.0002	19	20203.0100	17	26522.0000	7	28362.0000	9
01111.0002	19	20630.0008	27	26523.0000	5,7	28366.0000	5
01308.0000	11	20762.0000	25	26524.0000	5	28366.1000	7
01308.0002	27	20960.0000	13	26527.1003	25	28366.1001	7
01311.0000	5,7,13,25	20976.1000	21	26528.0000	7	28366.1002	7
01311.0001	5,7,13,15	20976.1001	21	26536.0003	27	28368.0000	7
01311.0001	17,19,25	20976.1002	21	26537.0000	11	28368.0004	7
01311.0004	19	21004.0338	11	26537.0001	11	28424.1003	13
01311.0003	7,17,25	21355.0001	13	26537.0003	11	28424.1004	13
01315.0000	19	21357.0000	13	26661.0000	19	28425.0000	13
01326.0000	19,23	21358.0000	13	26892.0000	9	28428.0006	15
01327.0000	27	21365.0000	13	26940.0002	13	28428.1000	15
01375.0000	27	21436.0000	7	27298.0500	9	28436.0000	5
01383.0001	9,11	21716.0000	9	27543.1001	11	28436.0003	5
01390.0000	9	21801.0015	17,23	27543.1002	11	28436.0004	5
01501.0000	17	21814.0016	19	27543.1005	11	28479.0000	19
01510.0000	25	22249.0000	19	27543.1006	11	28480.0000	19
01511.0000	13	22978.0000	17	27605.0000	27	28481.0000	19
01512.0000	27	23164.0002	7	27619.0000	9	28526.0000	17
01522.0000	9	23522.1000	25	27705.0000	27	28526.0001	23
01532.0000	19	23696.0000	25	27728.0002	27	28526.0002	23
01570.0000	17	23697.0000	25	28061.0000	13	28526.0003	23
01686.0000	25	23721.0000	19	28067.0000	13	28526.0004	19
02244.0000	27	23820.1000	19	28147.1000	9	28526.0005	23
02308.0000	5,17,27	24733.0010	15	28147.1002	9	28526.0006	23
02322.0002	19	24733.0011	23	28206.0000	7	28526.0025	19
02328.0002	9	25292.0000	9	28208.1000	15	28526.1000	17
02328.0003	25	25732.0000	15	28209.1000	5	28526.1001	17,21,23
02336.0000	9,15	25733.0000	15	28209.1001	5	28526.1002	17,21,23
02434.0009	15	25734.1000	15	28224.0000	25	28526.1003	17,21,23
02434.1000	15	25734.7002	15	28261.0000	9	28543.0000	9

NUMERICAL INDEX

PART NO.	PAGE NO.	PART NO.	PAGE NO.	PART NO.	PAGE NO.	PART NO.	PAGE NO.
28543.0003.....	9	32306.0000.....	15				
28548.0000.....	27	32337.0000.....	13				
28548.0001.....	27	32341.0000.....	23				
28548.0002.....	27	32383.0000.....	13				
28549.0000.....	11	32386.0000.....	13				
28661.0006.....	5	32386.0001.....	13				
28661.1000.....	5	32394.0000.....	13				
28661.1002.....	5	32906.0000.....	15				
28668.0000.....	7	33886.0000.....	5				
28670.0000.....	5	33886.0001.....	5				
28671.0000.....	5	34130.0000.....	9				
28680.0001.....	27	35155.0000.....	27				
28680.0004.....	27	36233.1000.....	21				
28682.0000.....	9	36378.0001.....	21				
28683.0000.....	25	36801.0001.....	27				
28684.0000.....	7	37297.0006.....	21				
28833.0000.....	11	37724.1001.....	7				
28833.0001.....	11	37881.0000.....	7				
28856.1000.....	25	37970.0000.....	23				
28857.1000.....	25	37978.1000.....	17				
28860.0000.....	25	37978.1001.....	17				
28860.0001.....	25	38031.0000.....	9				
28862.0000.....	27	38031.0001.....	9				
28864.0000.....	15	38053.0000.....	7				
28865.0000.....	15	39285.1001.....	23				
28866.0000.....	15	39285.1002.....	23				
28867.0000.....	15	39316.1001.....	23				
28869.0002.....	25	39316.1002.....	23				
28870.0000.....	9	39332.1000.....	25				
28872.0000.....	7	39642.0000.....	25				
28874.0000.....	7	38737.1000.....	27				
28910.0000.....	7	38894.0001.....	27				
29066.0000.....	11	38920.0008.....	27				
29066.0001.....	11	39803.0000.....	7				
29067.0000.....	27	40768.0000.....	9				
29067.0001.....	27	40782.0000.....	9				
29067.0007.....	27	40791.1006.....	25,27				
29081.0002.....	27	42996.1000.....	25				
29199.0000.....	27	43644.0000.....	21				
29216.0000.....	5	45965.1000.....	25				
29216.0001.....	5						
29216.0002.....	5						
29218.0000.....	7						
29218.0002.....	7						
29218.0007.....	7						
29243.0000.....	5						
29243.0001.....	5						
29243.0002.....	5						
29308.0000.....	9						
29329.1000.....	17						
29448.0000.....	9						
29642.1001.....	13						
29713.0000.....	13						
29933.1000.....	13						
32283.0000.....	21						