

InstaSlice™ Pusher Head Replacement

To ensure safe installation and operation, read the following statements and understand their meaning. Please read carefully.

⚠ WARNING

Warning is used to indicate the presence of a hazard that *can* cause severe personal injury, death, or substantial property damage if the warning is ignored.

SAFETY PRECAUTIONS

	<p>⚠ WARNING</p> <p>Sharp Blade Hazard. Blades are sharp and can cause cuts and amputation.</p>
<p>To avoid injury from sharp blades, handle with caution. Only trained personal should operate equipment or preform maintenance.</p>	

INSTALLATION PROCEDURES

1. Slide the pusher head assembly (A) out and away from the blade assembly (D). See Figure 1.

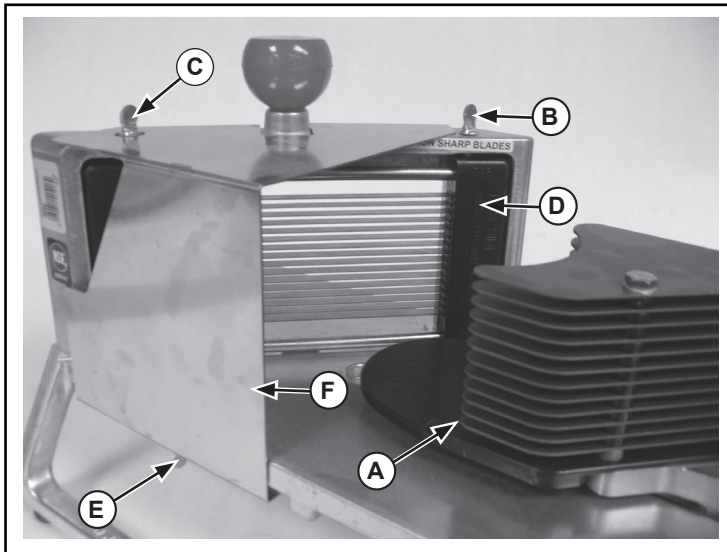

Figure 1. Blade Assembly and Guard Removal and Installation

2. Loosen the thumb screws (B and C) and carefully remove the blade assembly (D).
3. Remove the thumb screws (C and E) and the guard (F).

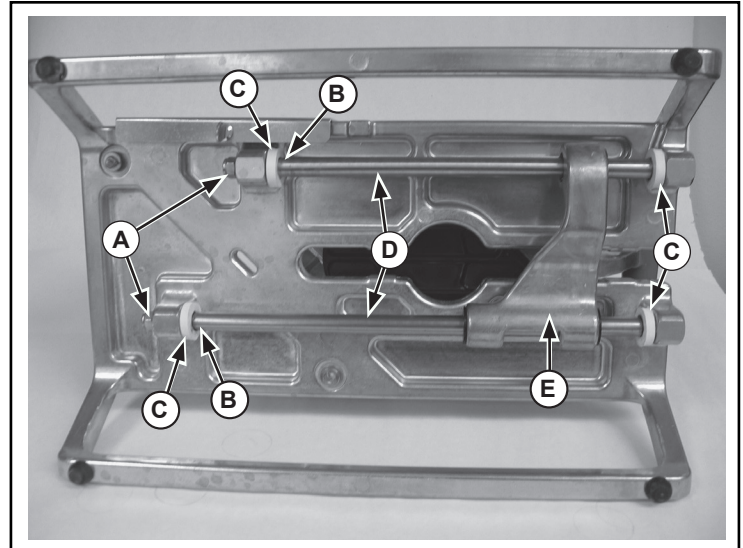

Figure 2. Guide Rod, Nylock Nut and Washer Removal and Installation

4. Hold the guide rods (D) using a wrench on the flats (B) and remove the nylock nuts (A). See Figure 2.
5. Note the position and location of the washers (C) and orientation of the pusher head assembly (E). Slowly remove the guide rods (D) and washers (C).
6. Retain the nylock nuts (A) for reuse. Retain the washers (C) if they are going to be reused or discard if they are going to be replaced.

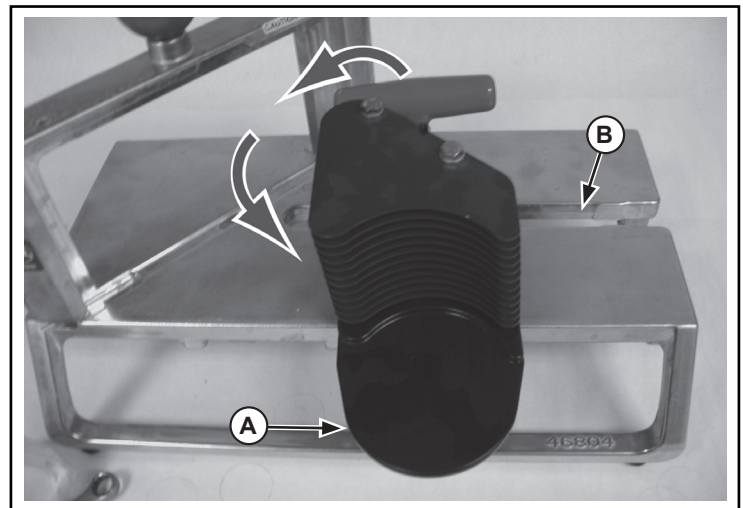

Figure 3. Pusher Head Assembly Removal

7. Rotate the pusher head (A) and remove by sliding out through slot (B). See Figure 3. Discard the old pusher head assembly.
8. Thoroughly wash the new pusher head assembly with hot and soapy water. Rinse thoroughly and allow to completely air dry. Use caution not to bend or damage the pusher fingers.



- Slide the new pusher head (A) handle first into the slot (B) and rotate until it is in the operating direction. See Figure 4.

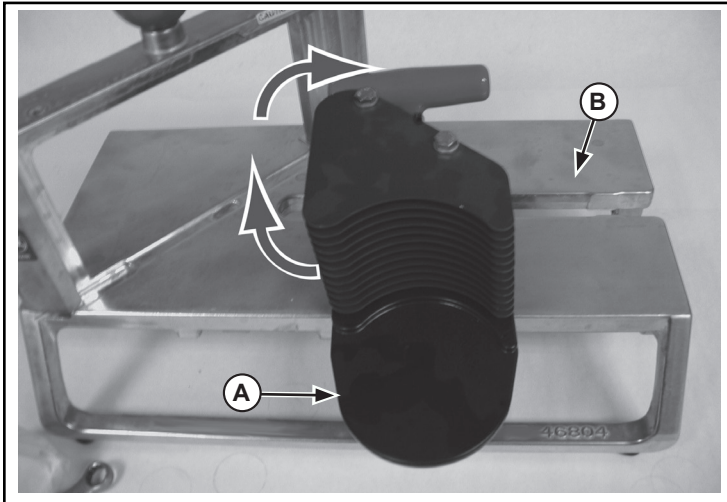

Figure 4. Installation of Pusher Head

- Install the guide rods (D) by sliding through bumpers (C) and pusher head (E) as shown in figure 2.
- Secure the guide rods (D) using the nylock nuts (A) removed earlier.
- Lubricate sliding parts with mineral oil or Petro Gel. Do not use cooking oil as it will become sticky and may permanently damage the equipment.
- Slide the pusher head back and forth on the guide rods.
- Slide the pusher head away from the slicing area.
- Install the blade assembly (D) securing with thumb screws (B and C). See Figure 1.
- Slowly slide the pusher head toward the blade assembly paying close attention to any blade and pusher head contact.

If the pusher head (A) slides through the blade assembly (D) without making contact with the blades:

- Reinstall the guard (F) securing with thumb screws (C and E). Your InstaSlice™ is now ready to use. See Figure 1.

If the pusher head (A) makes contact with the blades it will be necessary to change the position of the pusher fingers by:

- Note which pusher finger(s) (A) are making contact (C) with the blades (B). See Figure 5. See Figure 1.

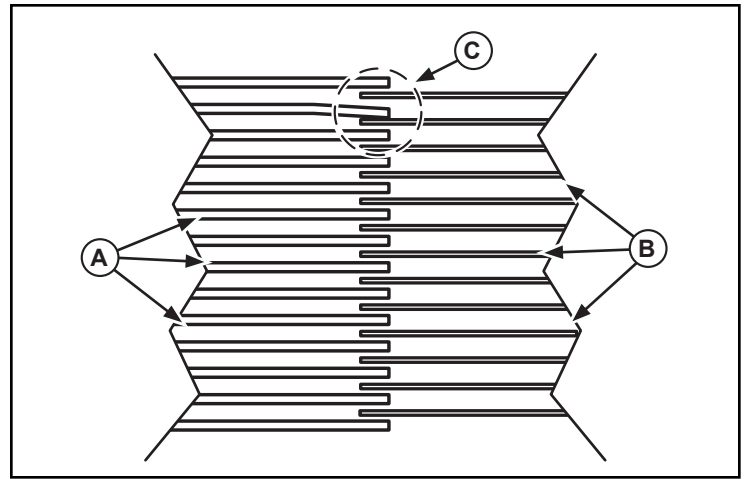

Figure 5. Pusher Head Fingers and Blade Assembly

- Hold a thin flat tool (B) on the pusher finger(s) that require adjustment. Tap the tool (B) with a mallet or similar tool. Use caution not to disrupt or make contact with another finger or to scratch the anodized surface of the pusher fingers. See Figure 6.

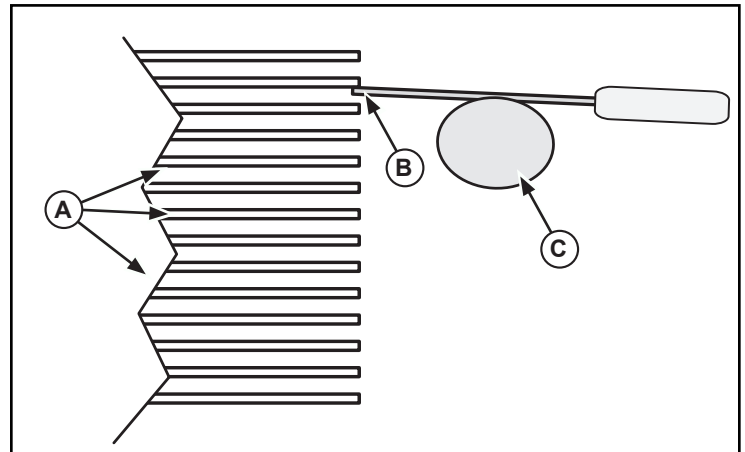

Figure 6. Adjusting the Pusher Head Fingers

- Slowly slide the pusher head toward the blade assembly paying close attention to any blade and pusher head contact. If the pusher head makes contact with the blades repeat previous steps 1 and 2.

Once the pusher head (A) slides through the blade assembly (D) without making contact with the blades:

- Reinstall the guard (F) securing with thumb screws (C and D). Your InstaSlice™ is now ready to use.



www.vollrathco.com

The Vollrath Company, L.L.C.
1236 North 18th Street
Sheboygan, WI 53081-3201
U.S.A.

Main Tel: 800.628.0830
Fax: 800.752.5620

Technical Services: 800.628.0832
Service Fax: 920.459.5462

Canada Service: 800.695.8560

© 2010 The Vollrath Company, L.L.C.